



回转传动解决方案

SLEWING DRIVE
SOLUTION



No.85 Yungu Road,Changshou,
Zhouzhuang Town,Jiangyin,Jiangsu,P.R.China
江苏省江阴市周庄镇长寿云顾路85号

+86 510-86366206
+86 510-86366117
+86 510-86366260

sales@conedrive.com.cn

科恩卓(江苏)传动有限公司
Cone Drive (Jiangsu) Power Transmission Co.,LTD

CONTENT 目录

CODE DESCRIPTION 编码说明	01
MOTORS OPTION 动力选配	02
COMPANY INTRODUCTION 公司简介	03
PROJECT CASE 工程案例	05

W SERIES W系列

W7	07
W9	08
W12	09
W14	10
W17	11
W19	12
W21	13
W25	14

WE SERIES WE系列

WE9	15
WE12	16
WE14	17
WE17	18
WE21	19
WE25	20
WE28	21

WEA SERIES WEA系列

WEA7	22
WEA9	23
WEA12	24
WEA14	25
WEA14-2	26
WEA15	27
WEA17	28
WEA17-2	29
WEA19B	30
WEA21	31
WEA21-2	32
WEA25	33
WEA25-2	34
WEA28	35

WEB SERIES WEB系列

WEB7	36
WEB9	37
WEB12	38
WEB14	39
WEB14-2	40
WEB15	41
WEB17	42
WEB17-2	43
WEB19B	44
WEB21	45
WEB21-2	46
WEB25	47
WEB25-2	48

SE/PE SERIES SE/PE系列

SE3C/PE3C	49
SE5C/PE5C	50
SE7A/PE7A	51
SE9A/PE9A	52
SE12A/PE12A	53
SE14A/PE14A	54
SE17A/PE17A	55
SE21/PE21	56
SE25/PE25	57

SEA/PEA SERIES SEA/PEA系列

SEA9/PEA9	58
SEA12/PEA12	59
SEA14/PEA14	60
SEA17/PEA17	61
SEA21/PEA21	62
SEA25/PEA25	63

SEB/PEB SERIES SEB/PEB系列

SEB7/PEB7	64
SEB9/PEB9	65
SEB12/PEB12	66
SEB14/PEB14	67
SEB17C/PEB17C	68
SEB21/PEB21	69
SEB25/PEB25	70

HSE SERIES HSE系列

HSE7	71
HSE9	72
HSE12	73
HSE14	74
HSE17	75
HSE19	76
HSE21A	77
HSE21A-2	78
HSE25	79
HSE25-2	80

HESPN SERIES HESPN系列

HESPN-0223	81
HESPH-0480	82

1000 SERIES 1000系列

83

4000 SERIES 4000系列

84

编码说明 CODE DESCRIPTION

Code:	1	2	3	4	5	6	7	8	9	10	11	12	13	14																																																																																																																																																																																
Description:	Model code				Gear	Worm shaft & Set position				Motor			OEM																																																																																																																																																																																	
Order information: (Example)	S	E	14	A	-	85	B	-	B	H	-	2	R	-	160	A	24,15,200	-	ZZ																																																																																																																																																																											
Option:	OEM customer special applies. 客户特殊要求																																																																																																																																																																																													
	<table border="0"> <tr> <td>24,15,200</td> <td>Motor code.</td> <td>电机型号</td> </tr> <tr> <td>None</td> <td>For hydraulic Motor or no motor.</td> <td>液压马达或无</td> </tr> <tr> <td>A</td> <td>Away, hydraulic port direction.</td> <td>液压马达进出口方向: 朝外.</td> </tr> <tr> <td>I</td> <td>In, hydraulic port direction.</td> <td>液压马达进出口方向: 朝内.</td> </tr> <tr> <td>U</td> <td>Up, hydraulic port direction.</td> <td>液压马达进出口方向: 朝上.</td> </tr> <tr> <td>D</td> <td>Down, hydraulic port direction.</td> <td>液压马达进出口方向: 朝下.</td> </tr> <tr> <td>None</td> <td>For electric Motor or no motor.</td> <td>电机或无</td> </tr> <tr> <td>160</td> <td>Hydraulic motor's displacement, cc/rev. (by design)</td> <td>液压马达排量, cc/rev. (设计需要)</td> </tr> <tr> <td>None</td> <td>For electric Motor or no motor.</td> <td>电机或无</td> </tr> <tr> <td>R</td> <td>Right, motor position</td> <td>马达右装.</td> </tr> <tr> <td>L</td> <td>Left, motor position</td> <td>马达左装.</td> </tr> <tr> <td>F</td> <td>Front, motor position</td> <td>马达前装.</td> </tr> <tr> <td>B</td> <td>Back, motor position</td> <td>马达后装.</td> </tr> <tr> <td>None</td> <td>Worm number, None means one worm.</td> <td>蜗杆数量, 默认为1.</td> </tr> <tr> <td>2</td> <td>Worm number, "2" means two worms</td> <td>蜗杆数量, 数量: 2.</td> </tr> <tr> <td>None</td> <td>End cap</td> <td>蜗杆非输入端为闷盖.</td> </tr> <tr> <td>H</td> <td>Hex extrusion</td> <td>蜗杆非输入端为六角头.</td> </tr> <tr> <td>E</td> <td>Encoder</td> <td>编码器(可选项, 非输入端).</td> </tr> <tr> <td>None</td> <td>Mounting motor</td> <td>安装电机或液压马达</td> </tr> <tr> <td>B</td> <td>SAE 6B spline</td> <td>SAE 6B花键.</td> </tr> <tr> <td>12</td> <td>12mm hole with keyway</td> <td>12mm公制键槽孔.</td> </tr> <tr> <td>16</td> <td>16mm hole with keyway</td> <td>16mm公制键槽孔.</td> </tr> <tr> <td>25</td> <td>25mm hole with keyway</td> <td>25mm公制键槽孔.</td> </tr> <tr> <td>None</td> <td>Metric blind screw hole.</td> <td>内、外圈公制螺纹盲孔.</td> </tr> <tr> <td>B</td> <td>Imperial blind screw hole.</td> <td>内、外圈英制螺纹盲孔.</td> </tr> <tr> <td>T</td> <td>Thru hole on inner ring and Metric blind screw hole on outer ring.</td> <td>内圈通光孔, 外圈公制螺纹盲孔.</td> </tr> <tr> <td>I</td> <td>Metric thru screw hole on inner ring and metric blind screw hole on outer ring.</td> <td>内圈公制螺纹通孔, 外圈公制螺纹盲孔.</td> </tr> <tr> <td>BT</td> <td>Thru hole on inner ring and Imperial blind screw hole on outer ring.</td> <td>内圈通光孔, 外圈英制螺纹盲孔.</td> </tr> <tr> <td>BI</td> <td>Imperial thru screw hole on inner ring and imperial blind screw hole on outer ring.</td> <td>内圈英制螺纹通孔, 外圈英制螺纹盲孔.</td> </tr> <tr> <td>85</td> <td>Reduction ratio, see code 3.</td> <td>减速比, 见编码3</td> </tr> <tr> <td>A</td> <td>Lip seal(S & W)or advanced (V)</td> <td>唇边密封条密封(S & W), 优化(V)</td> </tr> <tr> <td>C</td> <td>Dual seal</td> <td>双油封密封</td> </tr> <tr> <td>(2)</td> <td></td> <td>双滚道结构</td> </tr> <tr> <td>None</td> <td></td> <td>无</td> </tr> <tr> <td>3</td> <td>Size in inches of ball path diameter, reduction ratio:62.</td> <td>钢球滚道中心直径, 单位英寸, 减速比: 62.</td> </tr> <tr> <td>5</td> <td>Size in inches of ball path diameter, reduction ratio:62.</td> <td>钢球滚道中心直径, 单位英寸, 减速比: 62.</td> </tr> <tr> <td>7</td> <td>Size in inches of ball path diameter, reduction ratio:73, 60, 47.</td> <td>钢球滚道中心直径, 单位英寸, 减速比: 73, 60, 47.</td> </tr> <tr> <td>9</td> <td>Size in inches of ball path diameter, reduction ratio:61, 62.</td> <td>钢球滚道中心直径, 单位英寸, 减速比: 61, 62.</td> </tr> <tr> <td>12</td> <td>Size in inches of ball path diameter, reduction ratio:78, 79.</td> <td>钢球滚道中心直径, 单位英寸, 减速比: 78, 79.</td> </tr> <tr> <td>14</td> <td>Size in inches of ball path diameter, reduction ratio:85, 86.</td> <td>钢球滚道中心直径, 单位英寸, 减速比: 85, 86.</td> </tr> <tr> <td>17</td> <td>Size in inches of ball path diameter, reduction ratio:102, 81, 104.</td> <td>钢球滚道中心直径, 单位英寸, 减速比: 102, 81, 104.</td> </tr> <tr> <td>19</td> <td>Size in inches of ball path diameter, reduction ratio:93, 115.</td> <td>钢球滚道中心直径, 单位英寸, 减速比: 93, 115.</td> </tr> <tr> <td>21</td> <td>Size in inches of ball path diameter, reduction ratio:125, 90.</td> <td>钢球滚道中心直径, 单位英寸, 减速比: 125, 90.</td> </tr> <tr> <td>25</td> <td>Size in inches of ball path diameter, reduction ratio:150, 144, 104, 94, 108, 54.</td> <td>钢球滚道中心直径, 单位英寸, 减速比: 150, 144, 104, 94, 108, 54.</td> </tr> <tr> <td>E</td> <td>Enclosed housing slewing drive.</td> <td>围栏型回转驱动装置</td> </tr> <tr> <td>EA</td> <td>Oil seal</td> <td>油封密封</td> </tr> <tr> <td>EB</td> <td>Dual oil seal</td> <td>双油封密封</td> </tr> <tr> <td>None</td> <td>Open-housing slewing drive.</td> <td>非围栏型回转驱动装置.</td> </tr> <tr> <td>S</td> <td>Helical gear.</td> <td>斜齿型</td> </tr> <tr> <td>W</td> <td>Worm gear.</td> <td>蜗齿型</td> </tr> <tr> <td>Z</td> <td>Zero backlash.</td> <td>零间隙型</td> </tr> <tr> <td>P</td> <td>Precision, low backlash.</td> <td>精密型, 低间隙</td> </tr> <tr> <td>HS</td> <td>Heavy load, worm gear.</td> <td>重载型, 蜗齿</td> </tr> <tr> <td>SD</td> <td>Dual axis, helical gear.</td> <td>双轴型, 斜齿</td> </tr> <tr> <td>WD</td> <td>Dual axis, worm gear.</td> <td>双轴型, 蜗齿</td> </tr> <tr> <td>PD</td> <td>Dual axis, helical gear, precision.</td> <td>双轴型, 低间隙</td> </tr> <tr> <td>WDP</td> <td>Dual axis, helical gear, zero backlash raceway, precision.</td> <td>双轴型, 斜齿, 低间隙, 滚道零间隙</td> </tr> </table>																			24,15,200	Motor code.	电机型号	None	For hydraulic Motor or no motor.	液压马达或无	A	Away, hydraulic port direction.	液压马达进出口方向: 朝外.	I	In, hydraulic port direction.	液压马达进出口方向: 朝内.	U	Up, hydraulic port direction.	液压马达进出口方向: 朝上.	D	Down, hydraulic port direction.	液压马达进出口方向: 朝下.	None	For electric Motor or no motor.	电机或无	160	Hydraulic motor's displacement, cc/rev. (by design)	液压马达排量, cc/rev. (设计需要)	None	For electric Motor or no motor.	电机或无	R	Right, motor position	马达右装.	L	Left, motor position	马达左装.	F	Front, motor position	马达前装.	B	Back, motor position	马达后装.	None	Worm number, None means one worm.	蜗杆数量, 默认为1.	2	Worm number, "2" means two worms	蜗杆数量, 数量: 2.	None	End cap	蜗杆非输入端为闷盖.	H	Hex extrusion	蜗杆非输入端为六角头.	E	Encoder	编码器(可选项, 非输入端).	None	Mounting motor	安装电机或液压马达	B	SAE 6B spline	SAE 6B花键.	12	12mm hole with keyway	12mm公制键槽孔.	16	16mm hole with keyway	16mm公制键槽孔.	25	25mm hole with keyway	25mm公制键槽孔.	None	Metric blind screw hole.	内、外圈公制螺纹盲孔.	B	Imperial blind screw hole.	内、外圈英制螺纹盲孔.	T	Thru hole on inner ring and Metric blind screw hole on outer ring.	内圈通光孔, 外圈公制螺纹盲孔.	I	Metric thru screw hole on inner ring and metric blind screw hole on outer ring.	内圈公制螺纹通孔, 外圈公制螺纹盲孔.	BT	Thru hole on inner ring and Imperial blind screw hole on outer ring.	内圈通光孔, 外圈英制螺纹盲孔.	BI	Imperial thru screw hole on inner ring and imperial blind screw hole on outer ring.	内圈英制螺纹通孔, 外圈英制螺纹盲孔.	85	Reduction ratio, see code 3.	减速比, 见编码3	A	Lip seal(S & W)or advanced (V)	唇边密封条密封(S & W), 优化(V)	C	Dual seal	双油封密封	(2)		双滚道结构	None		无	3	Size in inches of ball path diameter, reduction ratio:62.	钢球滚道中心直径, 单位英寸, 减速比: 62.	5	Size in inches of ball path diameter, reduction ratio:62.	钢球滚道中心直径, 单位英寸, 减速比: 62.	7	Size in inches of ball path diameter, reduction ratio:73, 60, 47.	钢球滚道中心直径, 单位英寸, 减速比: 73, 60, 47.	9	Size in inches of ball path diameter, reduction ratio:61, 62.	钢球滚道中心直径, 单位英寸, 减速比: 61, 62.	12	Size in inches of ball path diameter, reduction ratio:78, 79.	钢球滚道中心直径, 单位英寸, 减速比: 78, 79.	14	Size in inches of ball path diameter, reduction ratio:85, 86.	钢球滚道中心直径, 单位英寸, 减速比: 85, 86.	17	Size in inches of ball path diameter, reduction ratio:102, 81, 104.	钢球滚道中心直径, 单位英寸, 减速比: 102, 81, 104.	19	Size in inches of ball path diameter, reduction ratio:93, 115.	钢球滚道中心直径, 单位英寸, 减速比: 93, 115.	21	Size in inches of ball path diameter, reduction ratio:125, 90.	钢球滚道中心直径, 单位英寸, 减速比: 125, 90.	25	Size in inches of ball path diameter, reduction ratio:150, 144, 104, 94, 108, 54.	钢球滚道中心直径, 单位英寸, 减速比: 150, 144, 104, 94, 108, 54.	E	Enclosed housing slewing drive.	围栏型回转驱动装置	EA	Oil seal	油封密封	EB	Dual oil seal	双油封密封	None	Open-housing slewing drive.	非围栏型回转驱动装置.	S	Helical gear.	斜齿型	W	Worm gear.	蜗齿型	Z	Zero backlash.	零间隙型	P	Precision, low backlash.	精密型, 低间隙	HS	Heavy load, worm gear.	重载型, 蜗齿	SD	Dual axis, helical gear.	双轴型, 斜齿	WD	Dual axis, worm gear.	双轴型, 蜗齿	PD	Dual axis, helical gear, precision.	双轴型, 低间隙	WDP	Dual axis, helical gear, zero backlash raceway, precision.	双轴型, 斜齿, 低间隙, 滚道零间隙
24,15,200	Motor code.	电机型号																																																																																																																																																																																												
None	For hydraulic Motor or no motor.	液压马达或无																																																																																																																																																																																												
A	Away, hydraulic port direction.	液压马达进出口方向: 朝外.																																																																																																																																																																																												
I	In, hydraulic port direction.	液压马达进出口方向: 朝内.																																																																																																																																																																																												
U	Up, hydraulic port direction.	液压马达进出口方向: 朝上.																																																																																																																																																																																												
D	Down, hydraulic port direction.	液压马达进出口方向: 朝下.																																																																																																																																																																																												
None	For electric Motor or no motor.	电机或无																																																																																																																																																																																												
160	Hydraulic motor's displacement, cc/rev. (by design)	液压马达排量, cc/rev. (设计需要)																																																																																																																																																																																												
None	For electric Motor or no motor.	电机或无																																																																																																																																																																																												
R	Right, motor position	马达右装.																																																																																																																																																																																												
L	Left, motor position	马达左装.																																																																																																																																																																																												
F	Front, motor position	马达前装.																																																																																																																																																																																												
B	Back, motor position	马达后装.																																																																																																																																																																																												
None	Worm number, None means one worm.	蜗杆数量, 默认为1.																																																																																																																																																																																												
2	Worm number, "2" means two worms	蜗杆数量, 数量: 2.																																																																																																																																																																																												
None	End cap	蜗杆非输入端为闷盖.																																																																																																																																																																																												
H	Hex extrusion	蜗杆非输入端为六角头.																																																																																																																																																																																												
E	Encoder	编码器(可选项, 非输入端).																																																																																																																																																																																												
None	Mounting motor	安装电机或液压马达																																																																																																																																																																																												
B	SAE 6B spline	SAE 6B花键.																																																																																																																																																																																												
12	12mm hole with keyway	12mm公制键槽孔.																																																																																																																																																																																												
16	16mm hole with keyway	16mm公制键槽孔.																																																																																																																																																																																												
25	25mm hole with keyway	25mm公制键槽孔.																																																																																																																																																																																												
None	Metric blind screw hole.	内、外圈公制螺纹盲孔.																																																																																																																																																																																												
B	Imperial blind screw hole.	内、外圈英制螺纹盲孔.																																																																																																																																																																																												
T	Thru hole on inner ring and Metric blind screw hole on outer ring.	内圈通光孔, 外圈公制螺纹盲孔.																																																																																																																																																																																												
I	Metric thru screw hole on inner ring and metric blind screw hole on outer ring.	内圈公制螺纹通孔, 外圈公制螺纹盲孔.																																																																																																																																																																																												
BT	Thru hole on inner ring and Imperial blind screw hole on outer ring.	内圈通光孔, 外圈英制螺纹盲孔.																																																																																																																																																																																												
BI	Imperial thru screw hole on inner ring and imperial blind screw hole on outer ring.	内圈英制螺纹通孔, 外圈英制螺纹盲孔.																																																																																																																																																																																												
85	Reduction ratio, see code 3.	减速比, 见编码3																																																																																																																																																																																												
A	Lip seal(S & W)or advanced (V)	唇边密封条密封(S & W), 优化(V)																																																																																																																																																																																												
C	Dual seal	双油封密封																																																																																																																																																																																												
(2)		双滚道结构																																																																																																																																																																																												
None		无																																																																																																																																																																																												
3	Size in inches of ball path diameter, reduction ratio:62.	钢球滚道中心直径, 单位英寸, 减速比: 62.																																																																																																																																																																																												
5	Size in inches of ball path diameter, reduction ratio:62.	钢球滚道中心直径, 单位英寸, 减速比: 62.																																																																																																																																																																																												
7	Size in inches of ball path diameter, reduction ratio:73, 60, 47.	钢球滚道中心直径, 单位英寸, 减速比: 73, 60, 47.																																																																																																																																																																																												
9	Size in inches of ball path diameter, reduction ratio:61, 62.	钢球滚道中心直径, 单位英寸, 减速比: 61, 62.																																																																																																																																																																																												
12	Size in inches of ball path diameter, reduction ratio:78, 79.	钢球滚道中心直径, 单位英寸, 减速比: 78, 79.																																																																																																																																																																																												
14	Size in inches of ball path diameter, reduction ratio:85, 86.	钢球滚道中心直径, 单位英寸, 减速比: 85, 86.																																																																																																																																																																																												
17	Size in inches of ball path diameter, reduction ratio:102, 81, 104.	钢球滚道中心直径, 单位英寸, 减速比: 102, 81, 104.																																																																																																																																																																																												
19	Size in inches of ball path diameter, reduction ratio:93, 115.	钢球滚道中心直径, 单位英寸, 减速比: 93, 115.																																																																																																																																																																																												
21	Size in inches of ball path diameter, reduction ratio:125, 90.	钢球滚道中心直径, 单位英寸, 减速比: 125, 90.																																																																																																																																																																																												
25	Size in inches of ball path diameter, reduction ratio:150, 144, 104, 94, 108, 54.	钢球滚道中心直径, 单位英寸, 减速比: 150, 144, 104, 94, 108, 54.																																																																																																																																																																																												
E	Enclosed housing slewing drive.	围栏型回转驱动装置																																																																																																																																																																																												
EA	Oil seal	油封密封																																																																																																																																																																																												
EB	Dual oil seal	双油封密封																																																																																																																																																																																												
None	Open-housing slewing drive.	非围栏型回转驱动装置.																																																																																																																																																																																												
S	Helical gear.	斜齿型																																																																																																																																																																																												
W	Worm gear.	蜗齿型																																																																																																																																																																																												
Z	Zero backlash.	零间隙型																																																																																																																																																																																												
P	Precision, low backlash.	精密型, 低间隙																																																																																																																																																																																												
HS	Heavy load, worm gear.	重载型, 蜗齿																																																																																																																																																																																												
SD	Dual axis, helical gear.	双轴型, 斜齿																																																																																																																																																																																												
WD	Dual axis, worm gear.	双轴型, 蜗齿																																																																																																																																																																																												
PD	Dual axis, helical gear, precision.	双轴型, 低间隙																																																																																																																																																																																												
WDP	Dual axis, helical gear, zero backlash raceway, precision.	双轴型, 斜齿, 低间隙, 滚道零间隙																																																																																																																																																																																												

动力选配 MOTORS OPTION

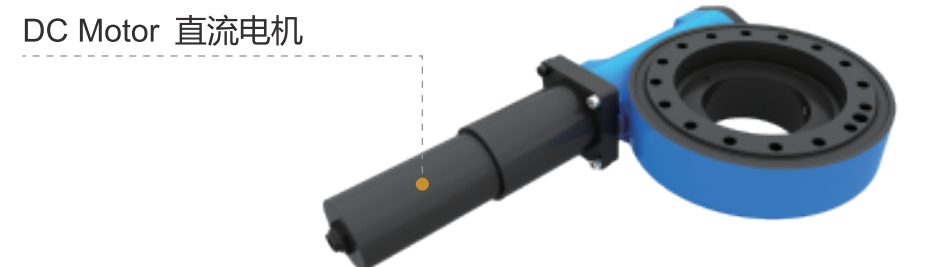
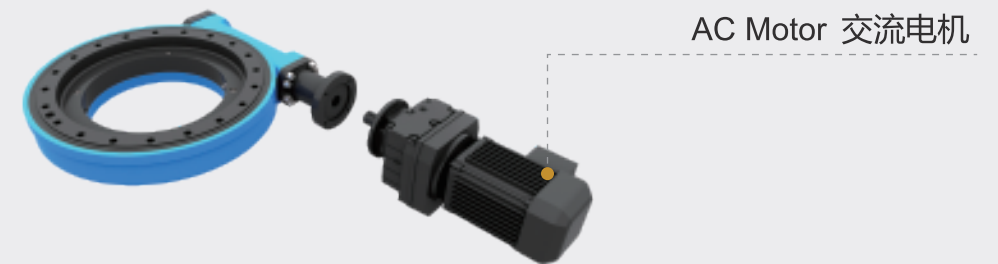
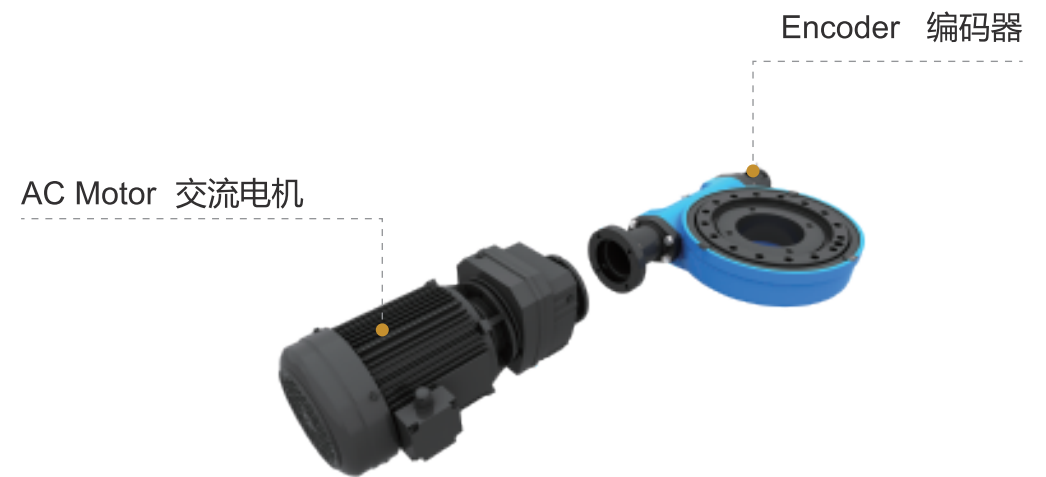

公司简介

COMPANY INTRODUCTION

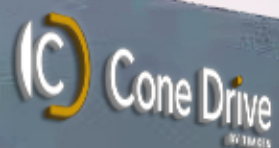

科恩卓（江苏）传动有限公司（原名：“江阴市华方新能源高科设备有限公司”），成立于2008年，是全球太阳能和工程机械回转减速器领域的领先企业，隶属于全球工程轴承及工业传动领域领导者美国铁姆肯公司。科恩卓秉持母公司的先进技术、工艺、产品及质量管理体系，并在此基础上持续创新。

科恩卓坚持以客户和产品为核心，集设计研发、智能制造和服务为一体，专注于技术以引领行业提升，为全球绿色可持续性发展提供高效的传动解决方案和定制化的高品质服务。

Cone Drive (Jiangsu) Power Transmission Co., LTD (Original name "Jiangyin Huafang New Energy High-Tech Equipment Co., LTD"), founded in 2008, Cone Drive is a US based world leader in precision motion control technology whose parent company is Timken, a world leader in engineered bearings and power transmission products. Inheriting the advanced technologies, processes, products and the Quality Management Systems from the parent company.

Cone Drive has been unremittingly pursuing innovation and excellence and has become a world leader in solar tracking systems and industry equipment applications. By cohesively integrating R&D, intelligent manufacturing, and service, which is centered with customers and products, Cone Drive is focusing on technology development so as to lead the industry, and provide most efficient slewing solutions and customized high-quality services for the global green and sustainable initiatives.

工程案例 PROJECT CASE



湿喷机 Wet Shotcreting Machine



高空作业车 Aerial Work Platform



抓木机 Forestry Machine



随车起重机 Truck Crane



混凝土搅拌车 Concrete Mixer



港口设备 Port Machine



自动转台 Machine Tools+ Automation



医疗设备 Medical Devices



巷道修复机 Roadway Repair Machine



多功能钻机 Multi-purpose Drill



清污车 Sewage Suction Truck



真空泵车 Vacuum Pump Truck

SLEWING DRIVE 回转式减速器

W7

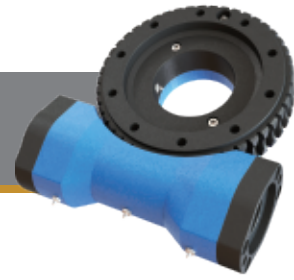

UNITS/单位:mm
1inch=25.4mm
Weight:29kg

FRONT VIEW 正视图

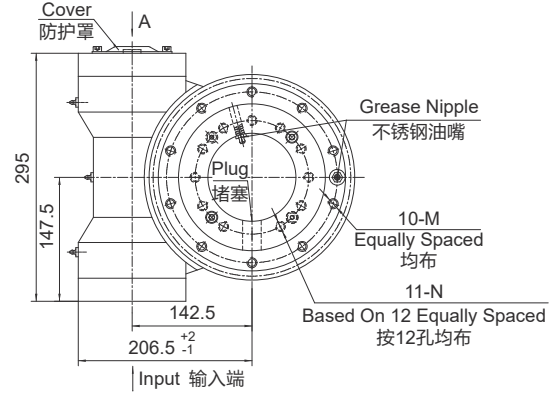

SIDE VIEW 侧视图

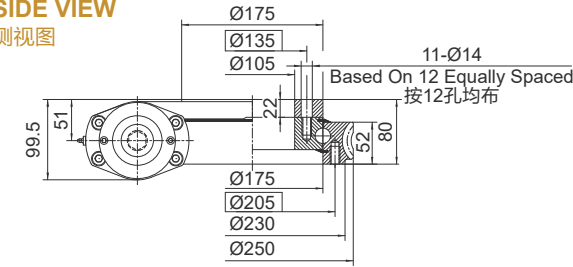

INPUT 输入端视图

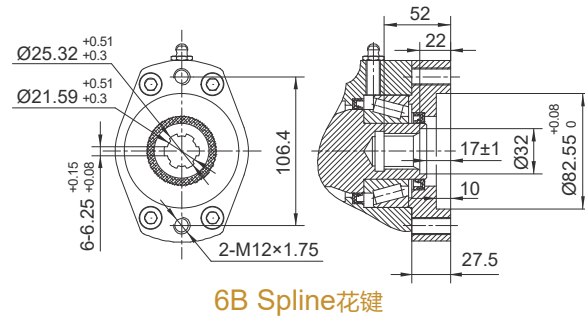
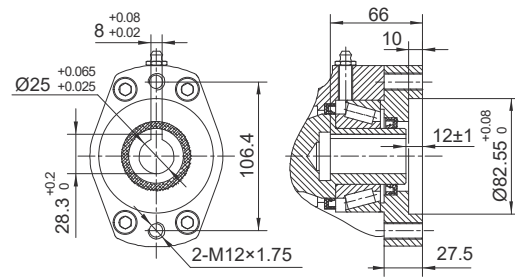

承载力矩图 MOMENT LOAD CHART

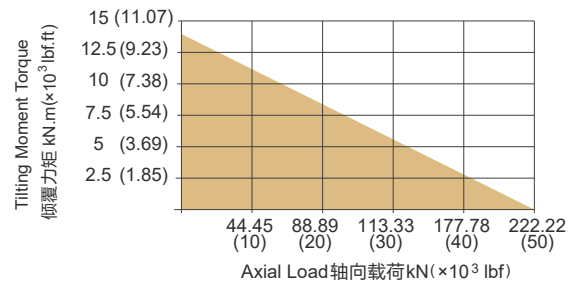

安装孔选项 Mounting Holes Option

Code 代码	M (Outer Ring 外圈)	N (Inner Ring 内圈)
—	M12x1.75 Tap (攻深)22	M12x1.75 Tap (攻深)22
T	M12x1.75 Tap (攻深)22	Ø14 Thru (通孔)
B	1/2"-13UNC-2B Tap (攻深)22	1/2"-13UNC-2B Tap (攻深)22
BT	1/2"-13UNC-2B Tap (攻深)22	Ø14 Thru (通孔)

性能参数表 Slewing Drive Performance Parameters

Output Torque	Tilting Moment Torque	Holding Torque	Static Axial Rating	Static Radial Rating	Dynamic Axial Rating	Dynamic Radial Rating	Gear Ratio	Tracking Precision	Weight
输出转矩	倾覆力矩	保持力矩	轴向静载荷	径向静载荷	轴向动载荷	径向动载荷	减速比	精度等级	重量
3.5 kN.m	14.2 kN.m	20 kN.m	220 kN	90 kN	63 kN	48 kN	47 : 1	≤ 0.15°	29kg
2583 lbf.ft	10.5x10³ lbf.ft	14.8x10³ lbf.ft	49.5x10³ lbf	20.2x10³ lbf	14.2x10³ lbf	10.8x10³ lbf			

"A" VIEW AS INPUT IS ALLOWED
输入端允许在 "A" 向视图

SPECIAL DESIGN BASE ON CUSTOMER'S REQUIREMENT
可根据顾客的要求进行非标设计



• Please be sure to remain under the curve. 选型时请确保实际载荷在曲线范围内。
• This drawing is just for your reference. 以上图纸仅供参考。
• This drawing is subject to change due to new design without prior notice. 本公司保留改进产品的权利而不再另行通知。
• Please contact the technical department for dimensions and performance parameters of the drives. 如果需要装置的外形尺寸和性能参数, 请与技术部门联系。

SLEWING DRIVE 回转式减速器

W9

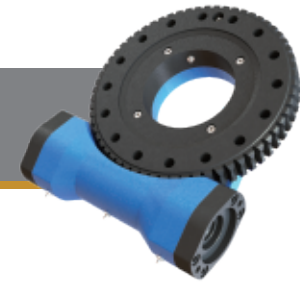

UNITS/单位:mm
1inch=25.4mm
Weight:40kg

FRONT VIEW 正视图

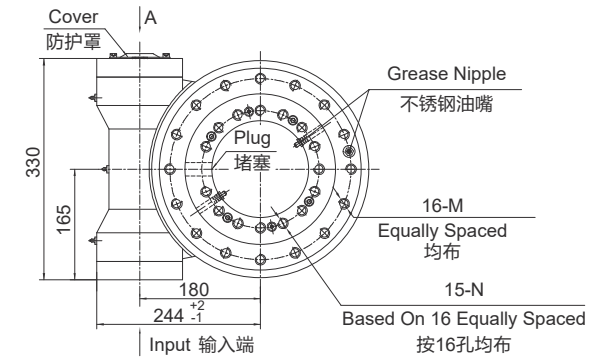

SIDE VIEW 侧视图

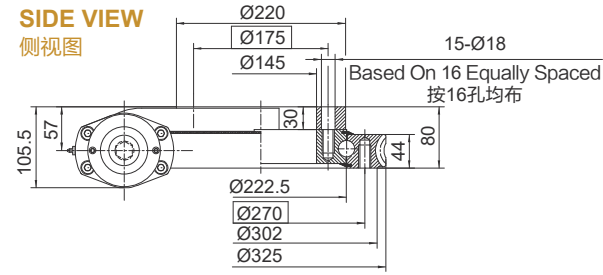

INPUT 输入端视图

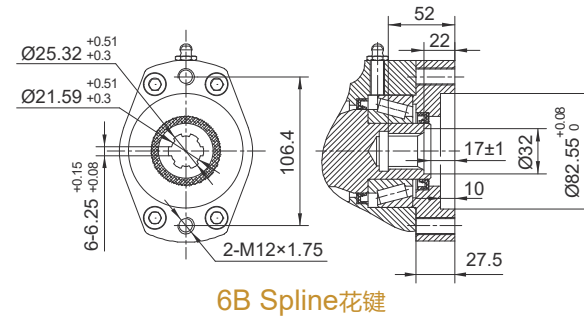
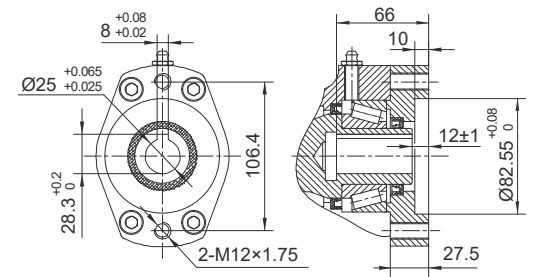

承载力矩图 MOMENT LOAD CHART

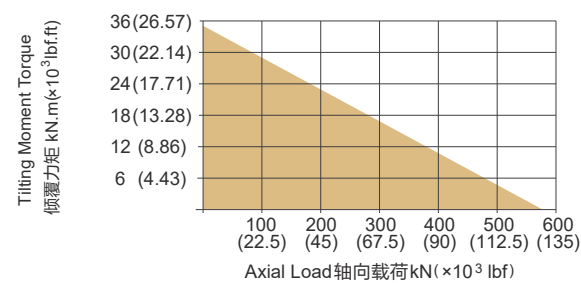

安装孔选项 Mounting Holes Option

Code 代码	M (Outer Ring 外圈)	N (Inner Ring 内圈)
—	M16x2 Tap (攻深)30	M16x2 Tap (攻深)30
T	M16x2 Tap (攻深)30	Ø18 Thru (通孔)
B	5/8"-11UNC-2B Tap (攻深)30	5/8"-11UNC-2B Tap (攻深)30
BT	5/8"-11UNC-2B Tap (攻深)30	Ø18 Thru (通孔)

性能参数表 Slewing Drive Performance Parameters

Output Torque	Tilting Moment Torque	Holding Torque	Static Axial Rating	Static Radial Rating	Dynamic Axial Rating	Dynamic Radial Rating	Gear Ratio	Tracking Precision	Weight
输出转矩	倾覆力矩	保持力矩	轴向静载荷	径向静载荷	轴向动载荷	径向动载荷	减速比	精度等级	重量
8 kN.m	35.6 kN.m	34.5 kN.m	578 kN	215 kN	136 kN	115 kN	62 : 1	≤ 0.15°	40kg
5904 lbf.ft	26.3x10³ lbf.ft	25.5x10³ lbf.ft	129.9x10³ lbf	48.3x10³ lbf	30.6x10³ lbf	25.9x10³ lbf			

"A" VIEW AS INPUT IS ALLOWED
输入端允许在 "A" 向视图

SPECIAL DESIGN BASE ON CUSTOMER'S REQUIREMENT
可根据顾客的要求进行非标设计



• Please be sure to remain under the curve. 选型时请确保实际载荷在曲线范围内。
• This drawing is just for your reference. 以上图纸仅供参考。
• This drawing is subject to change due to new design without prior notice. 本公司保留改进产品的权利而不再另行通知。
• Please contact the technical department for dimensions and performance parameters of the drives. 如果需要装置的外形尺寸和性能参数, 请与技术部门联系。

W12



UNITS/单位:mm
1inch=25.4mm
Weight:52kg

FRONT VIEW
正视图

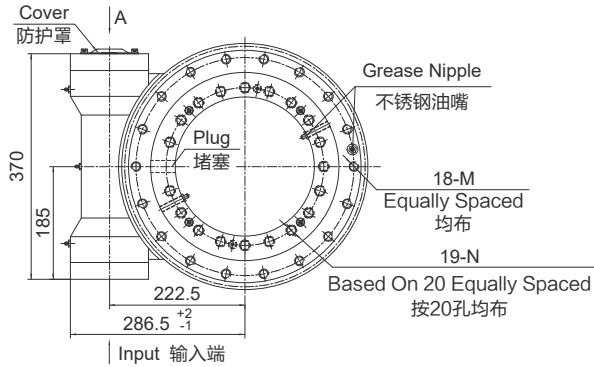

SIDE VIEW
侧视图

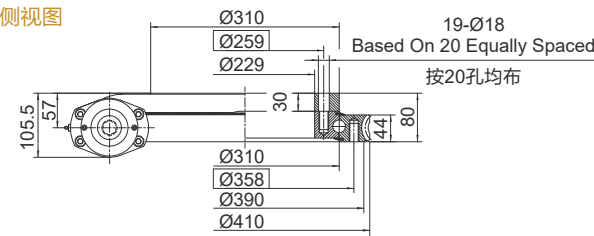

INPUT 输入端视图

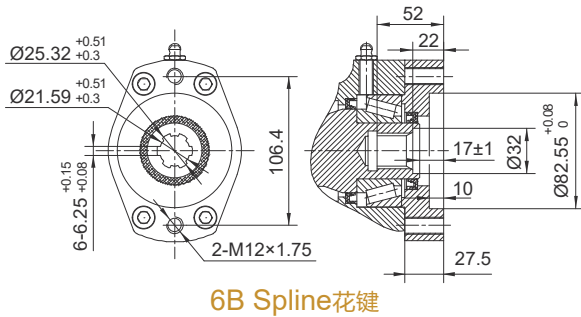
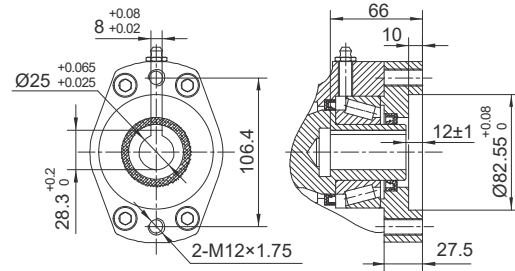

承载力矩图 MOMENT LOAD CHART

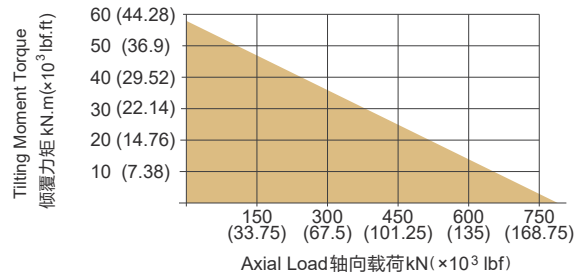

安装孔选项 Mounting Holes Option

Code 代码	M (Outer Ring 外圈)	N (Inner Ring 内圈)
—	M16×2 Tap (攻深)30	M16×2 Tap (攻深)30
T	M16×2 Tap (攻深)30	Ø18 Thru (通孔)
B	5/8"-11UNC-2B Tap (攻深)30	5/8"-11UNC-2B Tap (攻深)30
BT	5/8"-11UNC-2B Tap (攻深)30	Ø18Thru (通孔)

性能参数表 Slewing Drive Performance Parameters

Output Torque	Tilting Moment Torque	Holding Torque	Static Axial Rating	Static Radial Rating	Dynamic Axial Rating	Dynamic Radial Rating	Gear Ratio	Tracking Precision	Weight
输出转矩	倾覆力矩	保持力矩	轴向静载荷	径向静载荷	轴向动载荷	径向动载荷	减速比	精度等级	重量
9.5 kN.m	57 kN.m	43 kN.m	760 kN	280 kN	190 kN	148 kN	79 : 1	≤ 0.15°	52kg
7011 lbf.ft	42.1×10³ lbf.ft	32×10³ lbf.ft	171.1×10³ lbf	62.9×10³ lbf	42.7×10³ lbf	33.3×10³ lbf			

"A" VIEW AS INPUT IS ALLOWED
输入端允许在 "A" 向视图

SPECIAL DESIGN BASE ON CUSTOMER'S REQUIREMENT
可根据顾客的要求进行非标设计

NOTICE
Please be sure to remain under the curve. 选型时请确保实际载荷在曲线范围内。
This drawing is just for your reference. 以上图纸仅供参考。
This drawing is subject to change due to new design without prior notice. 本公司保留改进产品的权利而不再另行通知。
Please contact the technical department for dimensions and performance parameters of the drives. 如果需要装置的外形尺寸和性能参数, 请与技术部门联系。

W14

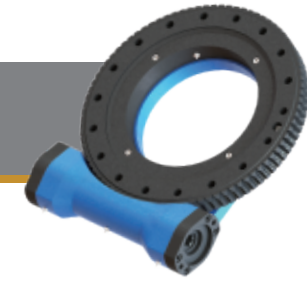

UNITS/单位:mm
1inch=25.4mm
Weight:62kg

FRONT VIEW
正视图

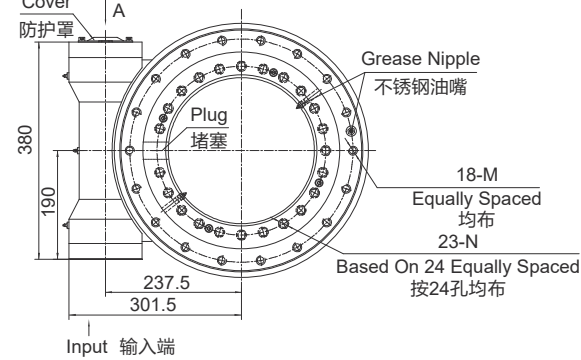

SIDE VIEW
侧视图

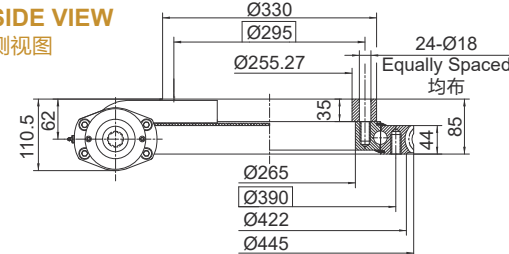

INPUT 输入端视图

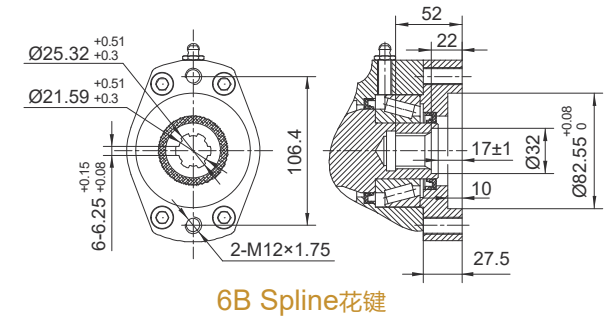
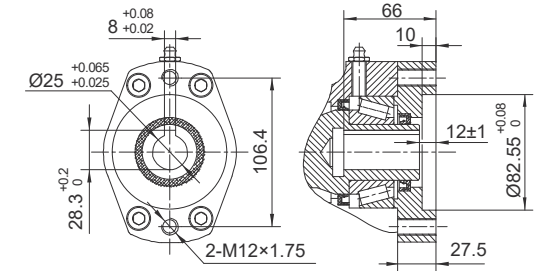

承载力矩图 MOMENT LOAD CHART

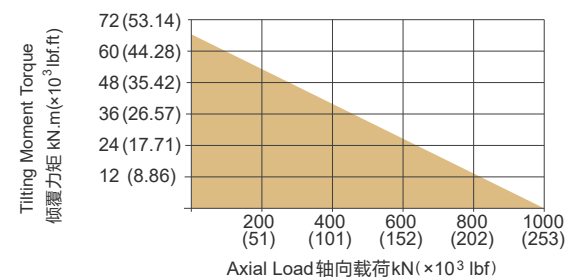

安装孔选项 Mounting Holes Option

Code 代码	M (Outer Ring 外圈)	N (Inner Ring 内圈)
—	M16×2 Tap (攻深)30	M16×2 Tap (攻深)30
T	M16×2 Tap (攻深)30	Ø18 Thru (通孔)
B	5/8"-11UNC-2B Tap (攻深)30	5/8"-11UNC-2B Tap (攻深)30
BT	5/8"-11UNC-2B Tap (攻深)30	Ø18 Thru (通孔)

性能参数表 Slewing Drive Performance Parameters

Output Torque	Tilting Moment Torque	Holding Torque	Static Axial Rating	Static Radial Rating	Dynamic Axial Rating	Dynamic Radial Rating	Gear Ratio	Tracking Precision	Weight
输出转矩	倾覆力矩	保持力矩	轴向静载荷	径向静载荷	轴向动载荷	径向动载荷	减速比	精度等级	重量
10.8 kN.m	71.2 kN.m	48 kN.m	960 kN	360 kN	230 kN	200 kN	86 : 1	≤ 0.13°	62kg
7970 lbf.ft	52.6×10³ lbf.ft	35×10³ lbf.ft	215.8×10³ lbf	80.9×10³ lbf	51.7×10³ lbf	44.9×10³ lbf			

"A" VIEW AS INPUT IS ALLOWED
输入端允许在 "A" 向视图

SPECIAL DESIGN BASE ON CUSTOMER'S REQUIREMENT
可根据顾客的要求进行非标设计

NOTICE
Please be sure to remain under the curve. 选型时请确保实际载荷在曲线范围内。
This drawing is just for your reference. 以上图纸仅供参考。
This drawing is subject to change due to new design without prior notice. 本公司保留改进产品的权利而不再另行通知。
Please contact the technical department for dimensions and performance parameters of the drives. 如果需要装置的外形尺寸和性能参数, 请与技术部门联系。

W17

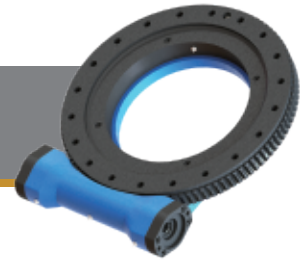

UNITS/单位:mm
1inch=25.4mm
Weight:82kg

FRONT VIEW
正视图

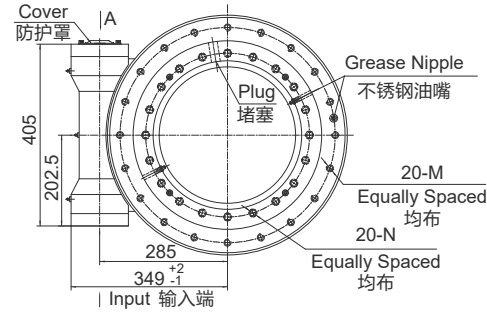

INPUT 输入端视图

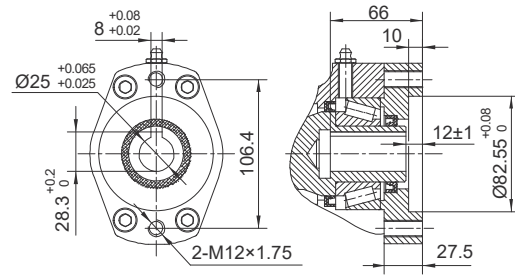

Ø25

SIDE VIEW
侧视图

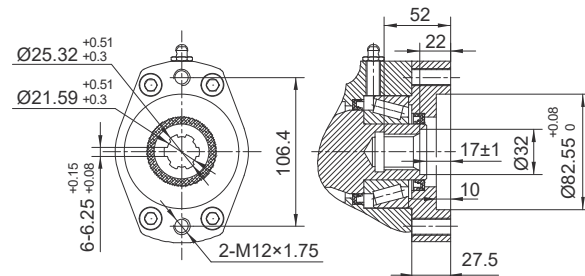
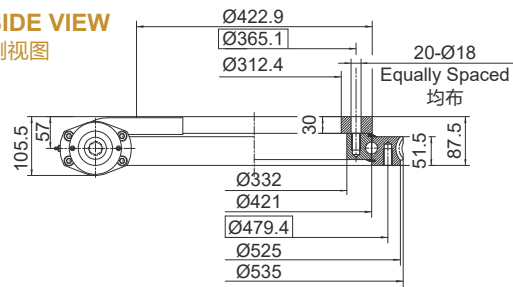

6B Spline花键

承载力矩图 MOMENT LOAD CHART

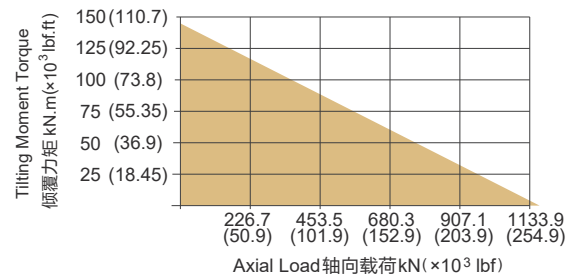

安装孔选项 Mounting Holes Option

Code 代码	M (Outer Ring 外圈)	N (Inner Ring 内圈)
—	M16x2 Tap (攻深)30	M16x2 Tap (攻深)30
T	M16x2 Tap (攻深)30	Ø18 Thru (通孔)
B	5/8"-11UNC-2B Tap (攻深)30	5/8"-11UNC-2B Tap (攻深)30
BT	5/8"-11UNC-2B Tap (攻深)30	Ø18 Thru (通孔)

性能参数表 Slewing Drive Performance Parameters

Output Torque	Tilting Moment Torque	Holding Torque	Static Axial Rating	Static Radial Rating	Dynamic Axial Rating	Dynamic Radial Rating	Gear Ratio	Tracking Precision	Weight
输出转矩	倾覆力矩	保持力矩	轴向静载荷	径向静载荷	轴向动载荷	径向动载荷	减速比	精度等级	重量
12.96 kN.m	142.4 kN.m	58 kN.m	1166 kN	435 kN	280 kN	231 kN	104 : 1	≤ 0.1°	82kg
9564 lbf.ft	105x10³ lbf.ft	42.8x10³ lbf.ft	262x10³ lbf	97.8x10³ lbf	62.9x10³ lbf	51.9x10³ lbf			

"A" VIEW AS INPUT IS ALLOWED
输入端允许在 "A" 向视图

SPECIAL DESIGN BASE ON CUSTOMER'S REQUIREMENT
可根据顾客的要求进行非标设计

NOTICE
Please be sure to remain under the curve. 选型时请确保实际载荷在曲线范围内。
This drawing is just for your reference. 以上图纸仅供参考。
This drawing is subject to change due to new design without prior notice. 本公司保留改进产品的权利而不再另行通知。
Please contact the technical department for dimensions and performance parameters of the drives. 如果需要装置的外形尺寸和性能参数, 请与技术部门联系。

W19

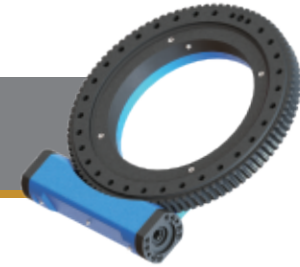

UNITS/单位:mm
1inch=25.4mm
Weight:95kg

FRONT VIEW
正视图

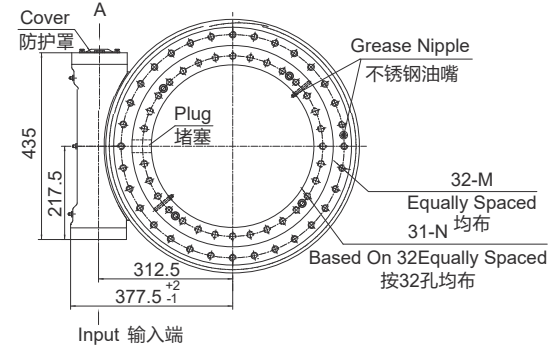

INPUT 输入端视图

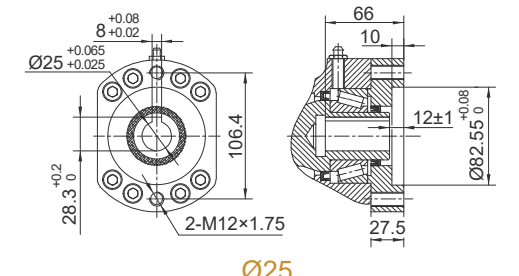

Ø25

SIDE VIEW
侧视图

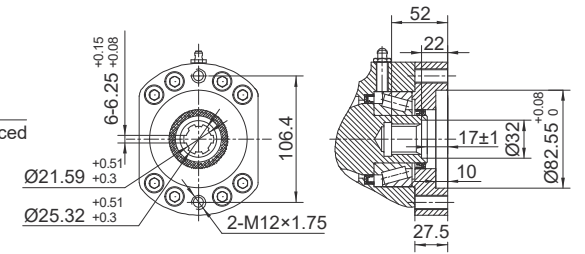
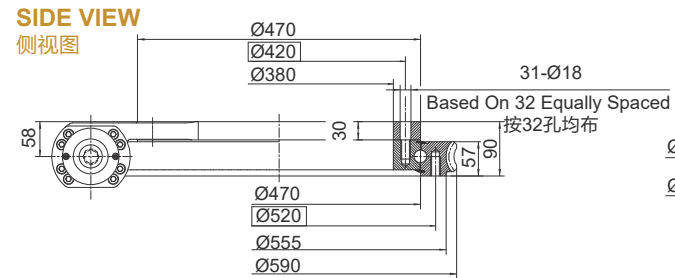

6B Spline花键

承载力矩图 MOMENT LOAD CHART

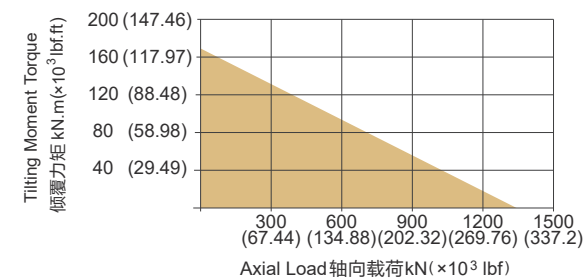

安装孔选项 Mounting Holes Option

Code 代码	M (Outer Ring 外圈)	N (Inner Ring 内圈)
—	M16x2 Tap (攻深)32	M16x2 Tap (攻深)32
T	M16x2 Tap (攻深)32	Ø18 Thru (通孔)
B	5/8"-11UNC-2B Tap (攻深)32	5/8"-11UNC-2B Tap (攻深)32
BT	5/8"-11UNC-2B Tap (攻深)32	Ø18 Thru (通孔)

性能参数表 Slewing Drive Performance Parameters

Output Torque	Tilting Moment Torque	Holding Torque	Static Axial Rating	Static Radial Rating	Dynamic Axial Rating	Dynamic Radial Rating	Gear Ratio	Tracking Precision	Weight
输出转矩	倾覆力矩	保持力矩	轴向静载荷	径向静载荷	轴向动载荷	径向动载荷	减速比	精度等级	重量
18.5 kN.m	170 kN.m	80.1 kN.m	1400 kN	525 kN	290 kN	250 kN	94 : 1	≤ 0.1°	95kg
13653 lbf.ft	125.5x10³ lbf.ft	59.1x10³ lbf.ft	314.7x10³ lbf	118x10³ lbf	65.2x10³ lbf	56.2x10³ lbf			

"A" VIEW AS INPUT IS ALLOWED
输入端允许在 "A" 向视图

SPECIAL DESIGN BASE ON CUSTOMER'S REQUIREMENT
可根据顾客的要求进行非标设计

NOTICE
Please be sure to remain under the curve. 选型时请确保实际载荷在曲线范围内。
This drawing is just for your reference. 以上图纸仅供参考。
This drawing is subject to change due to new design without prior notice. 本公司保留改进产品的权利而不再另行通知。
Please contact the technical department for dimensions and performance parameters of the drives. 如果需要装置的外形尺寸和性能参数, 请与技术部门联系。

W21

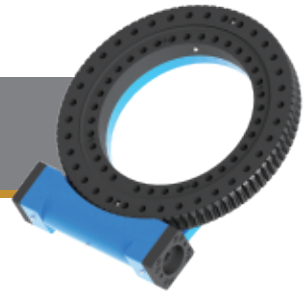

UNITS/单位:mm
1inch=25.4mm
Weight:139kg

FRONT VIEW 正视图

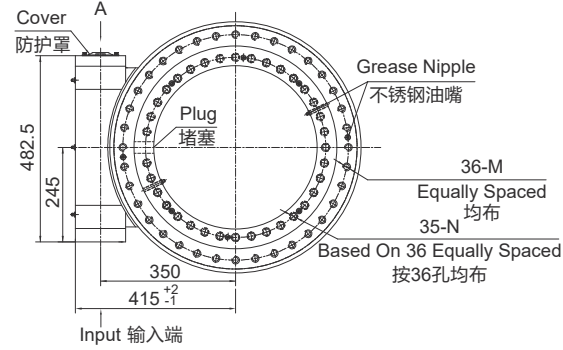

INPUT 输入端视图

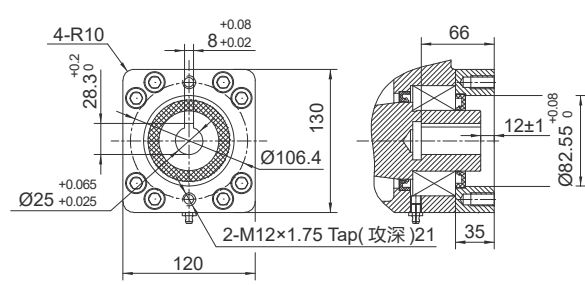

SIDE VIEW 侧视图

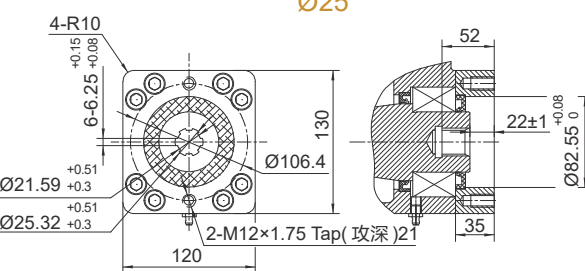
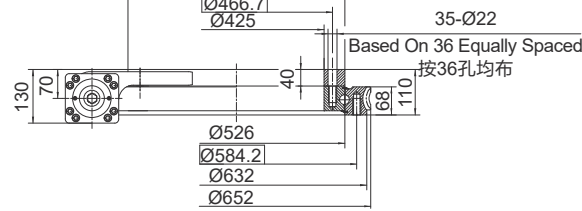

6B Spline花键

承载力矩图 MOMENT LOAD CHART

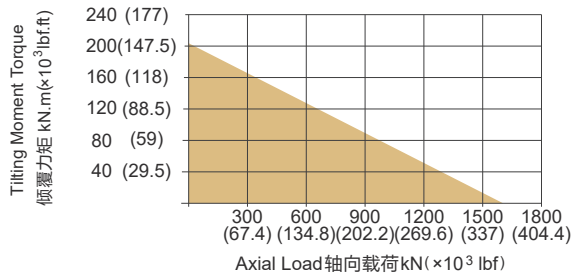

安装孔选项 Mounting Holes Option

Code 代码	M (Outer Ring 外圈)	N (Inner Ring 内圈)
—	M20×2.5 Tap (攻深)40	M20×2.5 Tap (攻深)40
T	M20×2.5 Tap (攻深)40	Ø18 Thru (通孔)
B	3/4"-10UNC-2B Tap (攻深)40	3/4"-10UNC-2B Tap (攻深)40
BT	3/4"-10UNC-2B Tap (攻深)40	Ø22 Thru (通孔)

性能参数表 Slewing Drive Performance Parameters

Output Torque	Tilting Moment Torque	Holding Torque	Static Axial Rating	Static Radial Rating	Dynamic Axial Rating	Dynamic Radial Rating	Gear Ratio	Tracking Precision	Weight
28.7 kN.m	203 kN.m	105.8 kN.m	1598 kN	640 kN	385 kN	335 kN	90 : 1	≤ 0.1°	139kg
21180 lbf.ft	105×10 ³ lbf.ft	78.1×10 ³ lbf.ft	359×10 ³ lbf	144×10 ³ lbf	87×10 ³ lbf	75×10 ³ lbf			

"A" VIEW AS INPUT IS ALLOWED
输入端允许在“A”向视图

SPECIAL DESIGN BASE ON CUSTOMER'S REQUIREMENT
可根据顾客的要求进行非标设计

- NOTICE 注意**
- Please be sure to remain under the curve. 选型时请确保实际载荷在曲线范围内。
 - This drawing is just for your reference. 以上图纸仅供参考。
 - This drawing is subject to change due to new design without prior notice. 本公司保留改进产品的权利而不再另行通知。
 - Please contact the technical department for dimensions and performance parameters of the drives. 如果需要装置的外形尺寸和性能参数, 请与技术部门联系。

W25

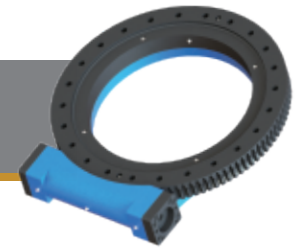

UNITS/单位:mm
1inch=25.4mm
Weight:176kg

FRONT VIEW 正视图

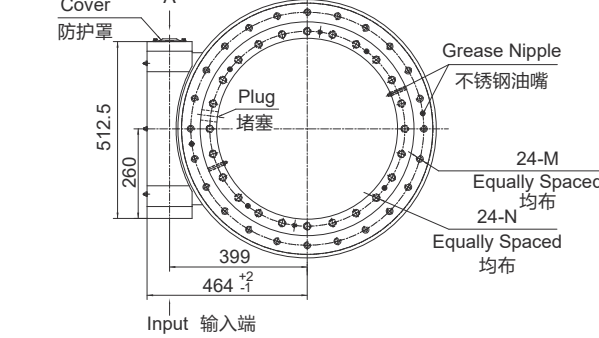

INPUT 输入端视图

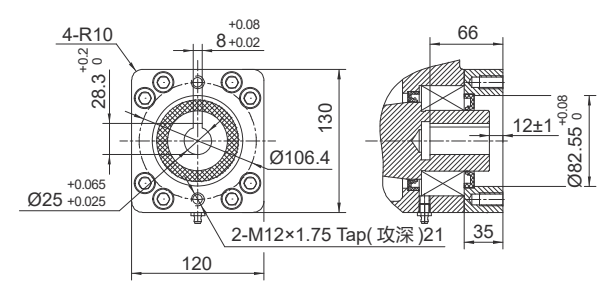

SIDE VIEW 侧视图

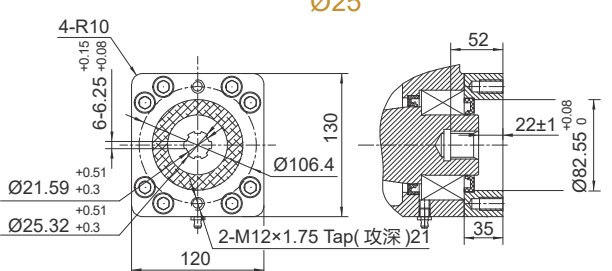
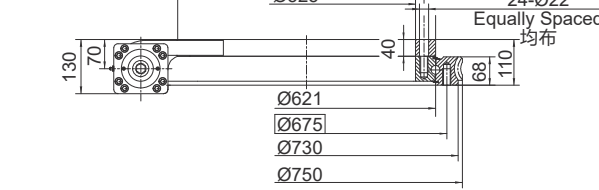

6B Spline花键

承载力矩图 MOMENT LOAD CHART

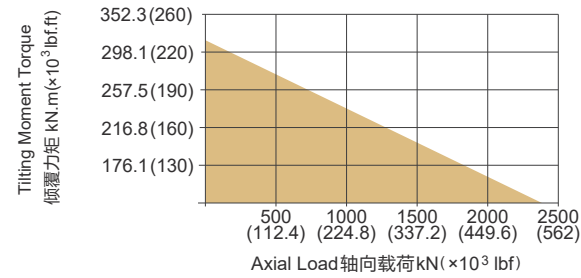

安装孔选项 Mounting Holes Option

Code 代码	M (Outer Ring 外圈)	N (Inner Ring 内圈)
—	M20×2.5 Tap (攻深)40	M20×2.5 Tap (攻深)40
T	M20×2.5 Tap (攻深)40	Ø22 Thru (通孔)
B	3/4"-10UNC-2B Tap (攻深)40	3/4"-10UNC-2B Tap (攻深)40
BT	3/4"-10UNC-2B Tap (攻深)40	Ø22 Thru (通孔)

性能参数表 Slewing Drive Performance Parameters

Output Torque	Tilting Moment Torque	Holding Torque	Static Axial Rating	Static Radial Rating	Dynamic Axial Rating	Dynamic Radial Rating	Gear Ratio	Tracking Precision	Weight
34.2 kN.m	310 kN.m	158.3 kN.m	2360 kN	945 kN	590 kN	470 kN	104 : 1	≤ 0.1°	176kg
25240 lbf.ft	229×10 ³ lbf.ft	117×10 ³ lbf.ft	531×10 ³ lbf	212×10 ³ lbf	133×10 ³ lbf	106×10 ³ lbf			

"A" VIEW AS INPUT IS ALLOWED
输入端允许在“A”向视图

SPECIAL DESIGN BASE ON CUSTOMER'S REQUIREMENT
可根据顾客的要求进行非标设计

- NOTICE 注意**
- Please be sure to remain under the curve. 选型时请确保实际载荷在曲线范围内。
 - This drawing is just for your reference. 以上图纸仅供参考。
 - This drawing is subject to change due to new design without prior notice. 本公司保留改进产品的权利而不再另行通知。
 - Please contact the technical department for dimensions and performance parameters of the drives. 如果需要装置的外形尺寸和性能参数, 请与技术部门联系。

WE9

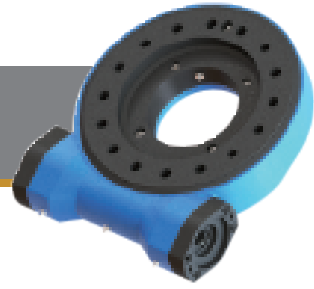

UNITS/单位:mm
1inch=25.4mm
Weight:48.5kg

FRONT VIEW 正视图

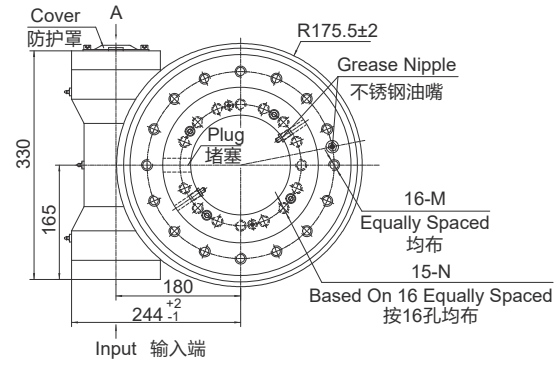

SIDE VIEW 侧视图

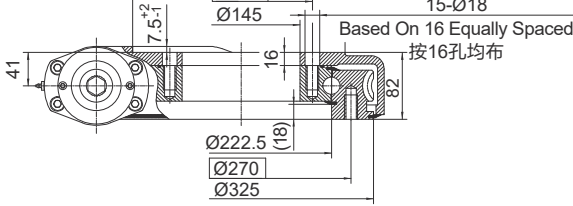

INPUT 输入端视图

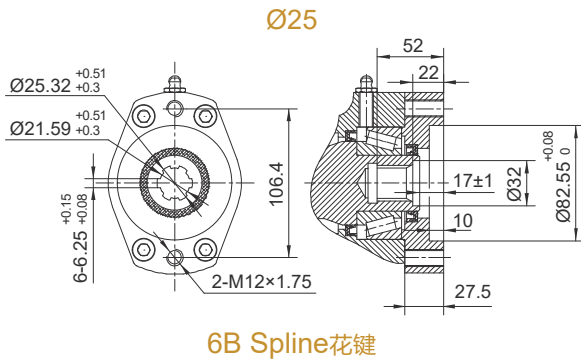
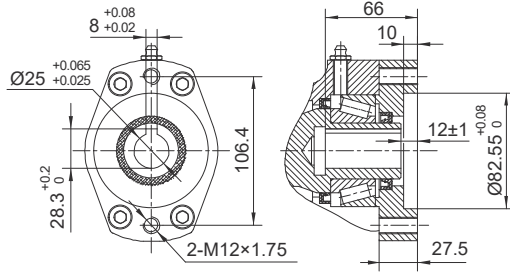

承载力矩图 MOMENT LOAD CHART

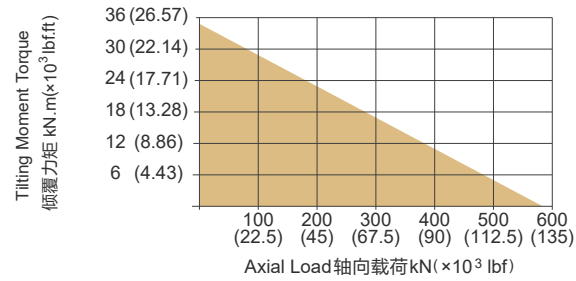

安装孔选项 Mounting Holes Option

Code 代码	M (Outer Ring 外圈)	N (Inner Ring 内圈)
—	M16×2 Tap (攻深)30	M16×2 Tap (攻深)30
T	M16×2 Tap (攻深)30	Ø18 Thru (通孔)
B	5/8"-11UNC-2B Tap (攻深)30	5/8"-11UNC-2B Tap (攻深)30
BT	5/8"-11UNC-2B Tap (攻深)30	Ø18 Thru (通孔)

性能参数表 Slewing Drive Performance Parameters

Output Torque	Tilting Moment Torque	Holding Torque	Static Axial Rating	Static Radial Rating	Dynamic Axial Rating	Dynamic Radial Rating	Gear Ratio	Tracking Precision	Weight
输出转矩	倾覆力矩	保持力矩	轴向静载荷	径向静载荷	轴向动载荷	径向动载荷	减速比	精度等级	重量
8 kN.m	35.6 kN.m	34.5 kN.m	578 kN	215 kN	136 kN	115 kN	62 : 1	≤ 0.15°	48.5kg
5904 lbf.ft	26.3×10 ³ lbf.ft	25.5×10 ³ lbf.ft	129.9×10 ³ lbf	48.3×10 ³ lbf	30.6×10 ³ lbf	25.9×10 ³ lbf			

"A" VIEW AS INPUT IS ALLOWED
输入端允许在 "A" 向视图

SPECIAL DESIGN BASE ON CUSTOMER'S REQUIREMENT
可根据顾客的要求进行非标设计

- NOTICE 注意**
- Please be sure to remain under the curve. 选型时请确保实际载荷在曲线范围内。
 - This drawing is just for your reference. 以上图纸仅供参考。
 - This drawing is subject to change due to new design without prior notice. 本公司保留改进产品的权利而不再另行通知。
 - Please contact the technical department for dimensions and performance parameters of the drives. 如果需要装置的外形尺寸和性能参数, 请与技术部门联系。

WE12

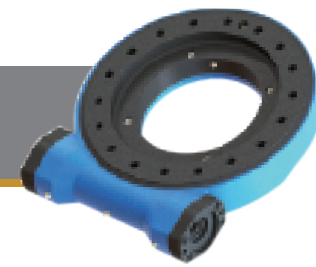

UNITS/单位:mm
1inch=25.4mm
Weight:61kg

FRONT VIEW 正视图

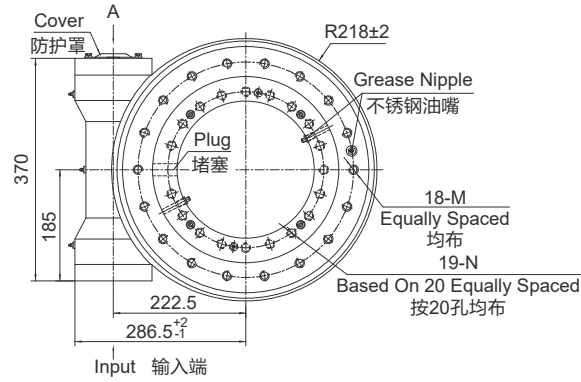

SIDE VIEW 侧视图

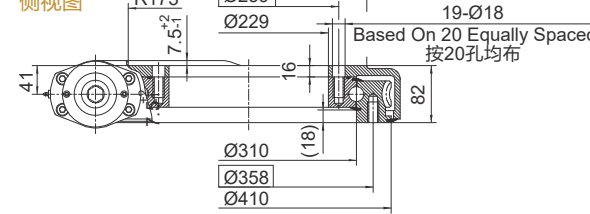

INPUT 输入端视图

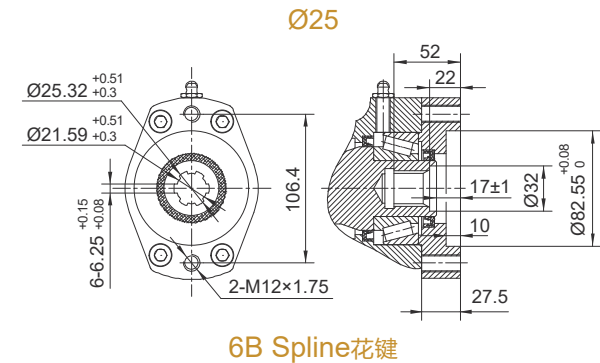
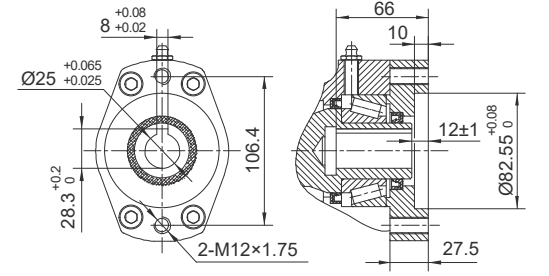

承载力矩图 MOMENT LOAD CHART

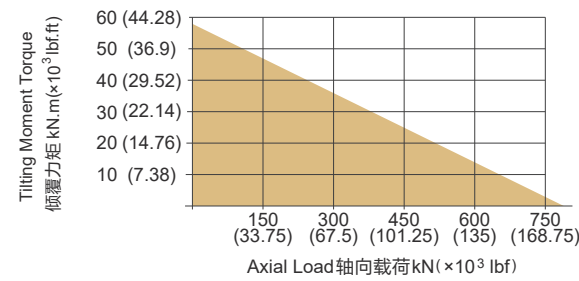

安装孔选项 Mounting Holes Option

Code 代码	M (Outer Ring 外圈)	N (Inner Ring 内圈)
—	M16×2 Tap (攻深)30	M16×2 Tap (攻深)30
T	M16×2 Tap (攻深)30	Ø18 Thru (通孔)
B	5/8"-11UNC-2B Tap (攻深)30	5/8"-11UNC-2B Tap (攻深)30
BT	5/8"-11UNC-2B Tap (攻深)30	Ø18 Thru (通孔)

性能参数表 Slewing Drive Performance Parameters

Output Torque	Tilting Moment Torque	Holding Torque	Static Axial Rating	Static Radial Rating	Dynamic Axial Rating	Dynamic Radial Rating	Gear Ratio	Tracking Precision	Weight
输出转矩	倾覆力矩	保持力矩	轴向静载荷	径向静载荷	轴向动载荷	径向动载荷	减速比	精度等级	重量
9.5 kN.m	57 kN.m	43 kN.m	760 kN	280 kN	190 kN	148 kN	79 : 1	≤ 0.15°	61kg
7011 lbf.ft	42.1×10 ³ lbf.ft	32×10 ³ lbf.ft	171.1×10 ³ lbf	62.9×10 ³ lbf	42.7×10 ³ lbf	33.3×10 ³ lbf			

"A" VIEW AS INPUT IS ALLOWED
输入端允许在 "A" 向视图

SPECIAL DESIGN BASE ON CUSTOMER'S REQUIREMENT
可根据顾客的要求进行非标设计

- NOTICE 注意**
- Please be sure to remain under the curve. 选型时请确保实际载荷在曲线范围内。
 - This drawing is just for your reference. 以上图纸仅供参考。
 - This drawing is subject to change due to new design without prior notice. 本公司保留改进产品的权利而不再另行通知。
 - Please contact the technical department for dimensions and performance parameters of the drives. 如果需要装置的外形尺寸和性能参数, 请与技术部门联系。

WE14

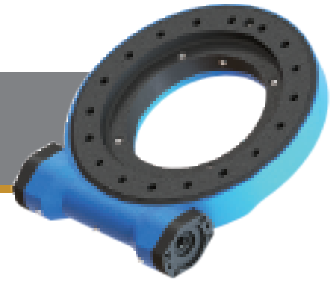

UNITS/单位:mm
1inch=25.4mm
Weight:68kg

FRONT VIEW 正视图

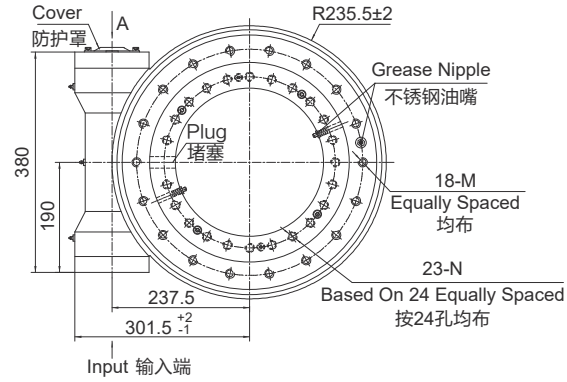

INPUT 输入端视图

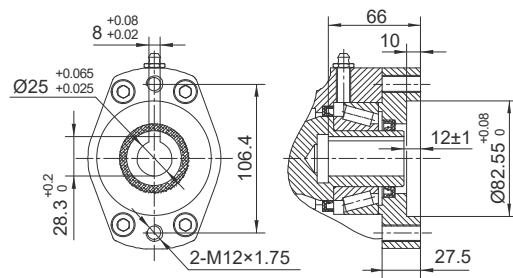

SIDE VIEW 侧视图

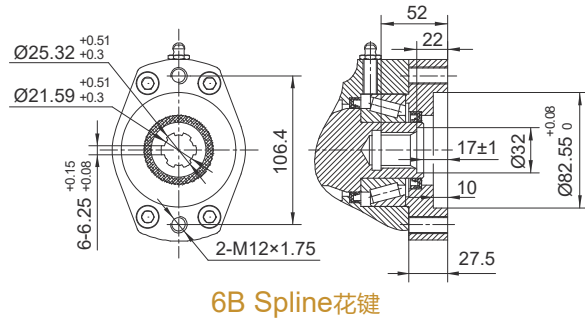
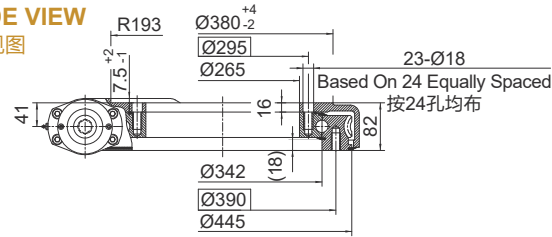

6B Spline花键

承载力矩图 MOMENT LOAD CHART

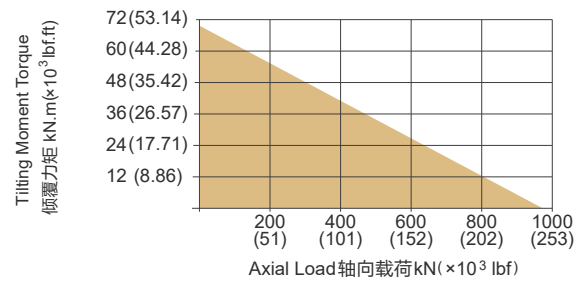

安装孔选项 Mounting Holes Option

Code 代码	M (Outer Ring 外圈)	N (Inner Ring 内圈)
—	M16×2 Tap (攻深)30	M16×2 Tap (攻深)30
T	M16×2 Tap (攻深)30	Ø18 Thru (通孔)
B	5/8"-11UNC-2B Tap (攻深)30	5/8"-11UNC-2B Tap (攻深)30
BT	5/8"-11UNC-2B Tap (攻深)30	Ø18 Thru (通孔)

性能参数表 Slewing Drive Performance Parameters

Output Torque	Tilting Moment Torque	Holding Torque	Static Axial Rating	Static Radial Rating	Dynamic Axial Rating	Dynamic Radial Rating	Gear Ratio	Tracking Precision	Weight
输出转矩	倾覆力矩	保持力矩	轴向静载荷	径向静载荷	轴向动载荷	径向动载荷	减速比	精度等级	重量
10.8 kN.m	71.2 kN.m	48 kN.m	960 kN	360 kN	230 kN	200 kN	86 : 1	≤ 0.13°	68kg
7970 lbf.ft	52.6×10 ³ lbf.ft	35×10 ³ lbf.ft	215.8×10 ³ lbf	80.9×10 ³ lbf	51.7×10 ³ lbf	44.9×10 ³ lbf			

WE17

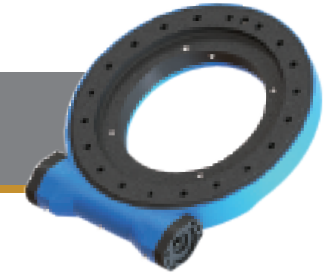

UNITS/单位:mm
1inch=25.4mm
Weight:90kg

FRONT VIEW 正视图

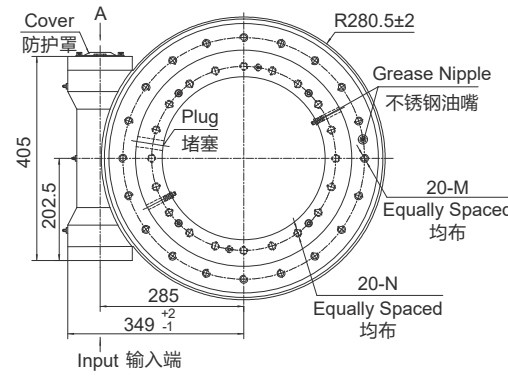

INPUT 输入端视图

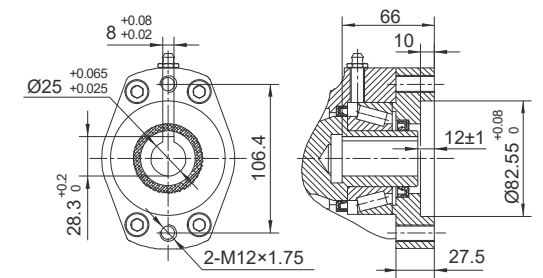

SIDE VIEW 侧视图

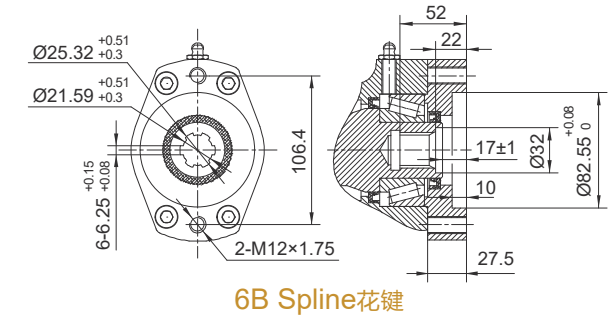
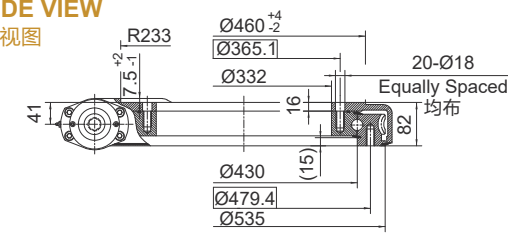

6B Spline花键

承载力矩图 MOMENT LOAD CHART

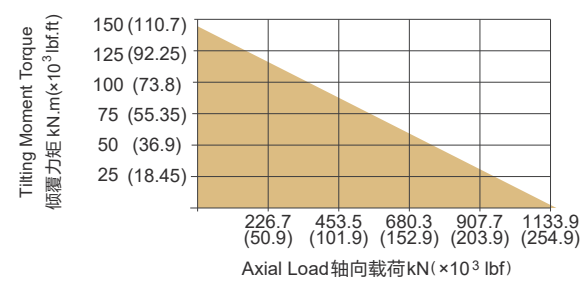

安装孔选项 Mounting Holes Option

Code 代码	M (Outer Ring 外圈)	N (Inner Ring 内圈)
—	M16×2 Tap (攻深)32	M16×2 Tap (攻深)32
T	M16×2 Tap (攻深)32	Ø18 Thru (通孔)
B	5/8"-11UNC-2B Tap (攻深)32	5/8"-11UNC-2B Tap (攻深)32
BT	5/8"-11UNC-2B Tap (攻深)32	Ø18 Thru (通孔)

性能参数表 Slewing Drive Performance Parameters

Output Torque	Tilting Moment Torque	Holding Torque	Static Axial Rating	Static Radial Rating	Dynamic Axial Rating	Dynamic Radial Rating	Gear Ratio	Tracking Precision	Weight
输出转矩	倾覆力矩	保持力矩	轴向静载荷	径向静载荷	轴向动载荷	径向动载荷	减速比	精度等级	重量
12.96 kN.m	142.4 kN.m	58 kN.m	1166 kN	435 kN	280 kN	231 kN	104 : 1	≤ 0.1°	90kg
9564 lbf.ft	105×10 ³ lbf.ft	42.8×10 ³ lbf.ft	262×10 ³ lbf	97.8×10 ³ lbf	62.9×10 ³ lbf	51.9×10 ³ lbf			

"A" VIEW AS INPUT IS ALLOWED
输入端允许在 "A" 向视图

SPECIAL DESIGN BASE ON CUSTOMER'S REQUIREMENT
可根据顾客的要求进行非标设计



NOTICE 注意
• Please be sure to remain under the curve. 选型时请确保实际载荷在曲线范围内。
• This drawing is just for your reference. 以上图纸仅供参考。
• This drawing is subject to change due to new design without prior notice. 本公司保留改进产品的权利而不再另行通知。
• Please contact the technical department for dimensions and performance parameters of the drives. 如果需要装置的外形尺寸和性能参数, 请与技术部门联系。

"A" VIEW AS INPUT IS ALLOWED
输入端允许在 "A" 向视图

SPECIAL DESIGN BASE ON CUSTOMER'S REQUIREMENT
可根据顾客的要求进行非标设计



NOTICE 注意
• Please be sure to remain under the curve. 选型时请确保实际载荷在曲线范围内。
• This drawing is just for your reference. 以上图纸仅供参考。
• This drawing is subject to change due to new design without prior notice. 本公司保留改进产品的权利而不再另行通知。
• Please contact the technical department for dimensions and performance parameters of the drives. 如果需要装置的外形尺寸和性能参数, 请与技术部门联系。

WE21

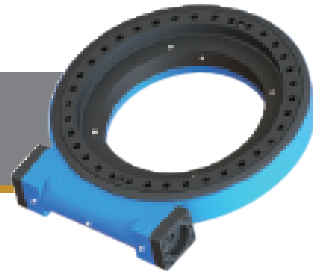

UNITS/单位:mm
1inch=25.4mm
Weight:169kg

FRONT VIEW 正视图

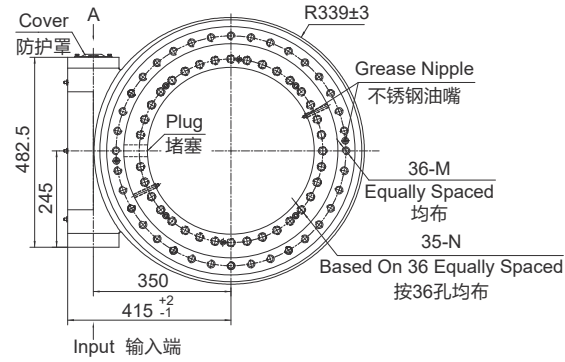

INPUT 输入端视图

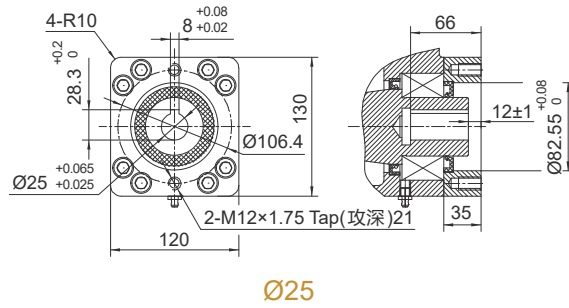

SIDE VIEW 侧视图

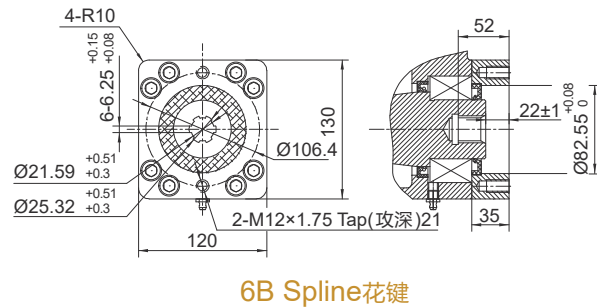
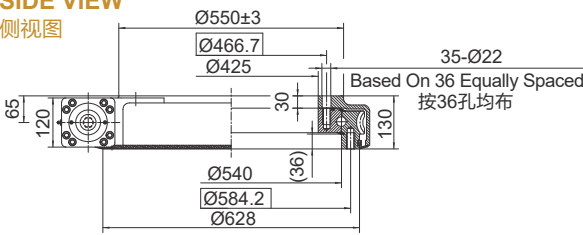

承载力矩图 MOMENT LOAD CHART

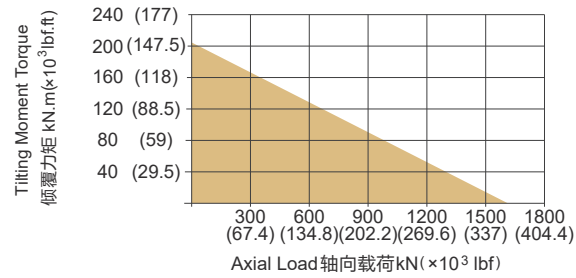

安装孔选项 Mounting Holes Option

Code 代码	M (Outer Ring 外圈)	N (Inner Ring 内圈)
—	M20×2.5 Tap (攻深)40	M20×2.5 Tap (攻深)40
T	M20×2.5 Tap (攻深)40	Ø22 Thru (通孔)
B	3/4"-10UNC-2B Tap (攻深)40	3/4"-10UNC-2B Tap (攻深)40
BT	3/4"-10UNC-2B Tap (攻深)40	Ø22 Thru (通孔)

性能参数表 Slewing Drive Performance Parameters

Output Torque	Tilting Moment Torque	Holding Torque	Static Axial Rating	Static Radial Rating	Dynamic Axial Rating	Dynamic Radial Rating	Gear Ratio	Tracking Precision	Weight
28.7 kN.m	203 kN.m	105.8 kN.m	1598 kN	640 kN	385 kN	335 kN	90 : 1	≤ 0.1°	169kg
21180 lbf.ft	150×10 ³ lbf.ft	78.1×10 ³ lbf.ft	359×10 ³ lbf	144×10 ³ lbf	87×10 ³ lbf	75×10 ³ lbf			

"A" VIEW AS INPUT IS ALLOWED
输入端允许在“A”向视图

SPECIAL DESIGN BASE ON CUSTOMER'S REQUIREMENT
可根据顾客的要求进行非标设计

NOTICE 注意

- Please be sure to remain under the curve. 选型时请确保实际载荷在曲线范围内。
- This drawing is just for your reference. 以上图纸仅供参考。
- This drawing is subject to change due to new design without prior notice. 本公司保留改进产品的权利而不再另行通知。
- Please contact the technical department for dimensions and performance parameters of the drives. 如果需要装置的外形尺寸和性能参数, 请与技术部门联系。

WE25

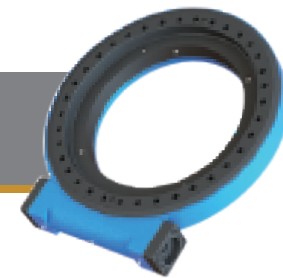

UNITS/单位:mm
1inch=25.4mm
Weight:199kg

FRONT VIEW 正视图

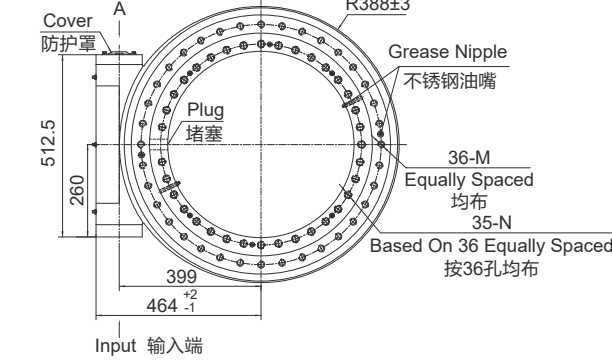

INPUT 输入端视图

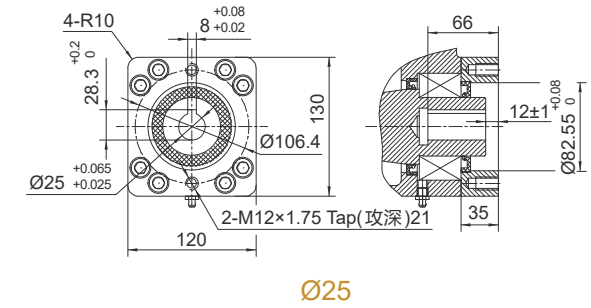

SIDE VIEW 侧视图

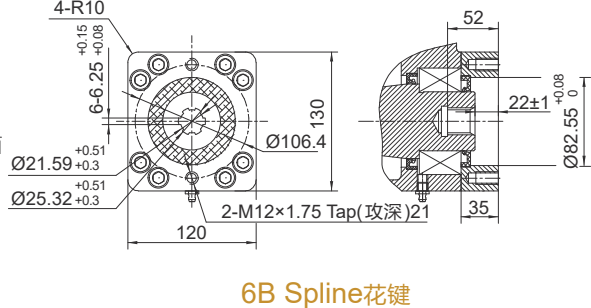
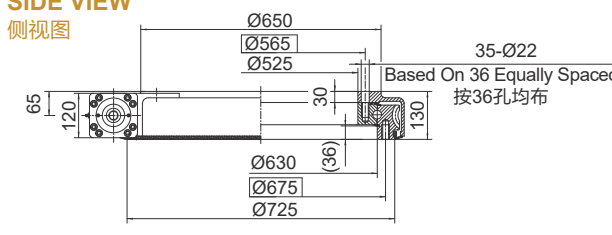

承载力矩图 MOMENT LOAD CHART

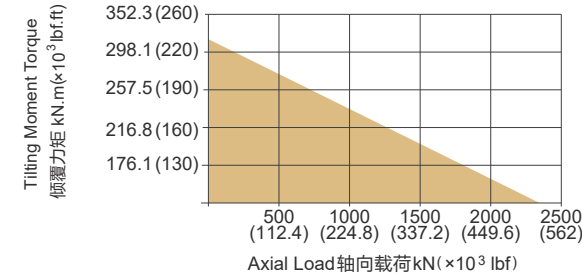

安装孔选项 Mounting Holes Option

Code 代码	M (Outer Ring 外圈)	N (Inner Ring 内圈)
—	M20×2.5 Tap (攻深)40	M20×2.5 Tap (攻深)40
T	M20×2.5 Tap (攻深)40	Ø22 Thru (通孔)
B	3/4"-10UNC-2B Tap (攻深)40	3/4"-10UNC-2B Tap (攻深)40
BT	3/4"-10UNC-2B Tap (攻深)40	Ø22 Thru (通孔)

性能参数表 Slewing Drive Performance Parameters

Output Torque	Tilting Moment Torque	Holding Torque	Static Axial Rating	Static Radial Rating	Dynamic Axial Rating	Dynamic Radial Rating	Gear Ratio	Tracking Precision	Weight
34.2 kN.m	310 kN.m	158.3 kN.m	2360 kN	945 kN	590 kN	470 kN	104 : 1	≤ 0.1°	199kg
25240 lbf.ft	229×10 ³ lbf.ft	117×10 ³ lbf.ft	531×10 ³ lbf	212×10 ³ lbf	133×10 ³ lbf	106×10 ³ lbf			

"A" VIEW AS INPUT IS ALLOWED
输入端允许在“A”向视图

SPECIAL DESIGN BASE ON CUSTOMER'S REQUIREMENT
可根据顾客的要求进行非标设计

NOTICE 注意

- Please be sure to remain under the curve. 选型时请确保实际载荷在曲线范围内。
- This drawing is just for your reference. 以上图纸仅供参考。
- This drawing is subject to change due to new design without prior notice. 本公司保留改进产品的权利而不再另行通知。
- Please contact the technical department for dimensions and performance parameters of the drives. 如果需要装置的外形尺寸和性能参数, 请与技术部门联系。

WE28

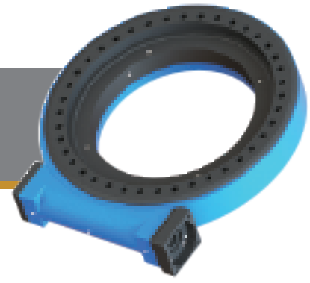

UNITS/单位:mm
1inch=25.4mm
Weight:403kg

FRONT VIEW
正视图

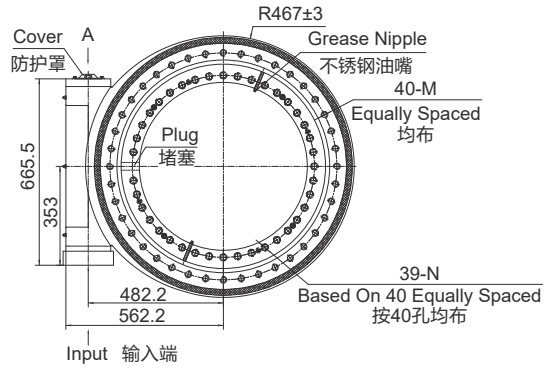

INPUT 输入端视图

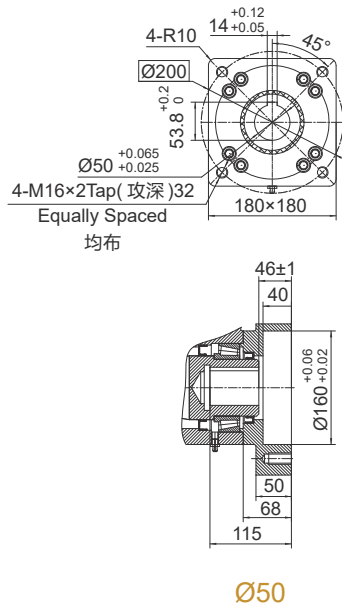

SIDE VIEW
侧视图

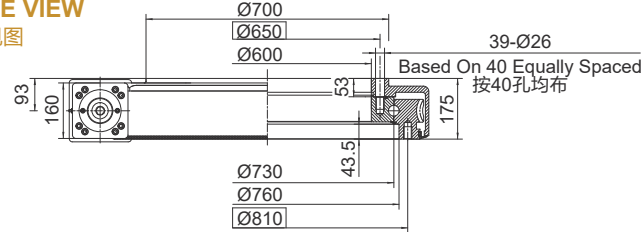

承载力矩图 MOMENT LOAD CHART

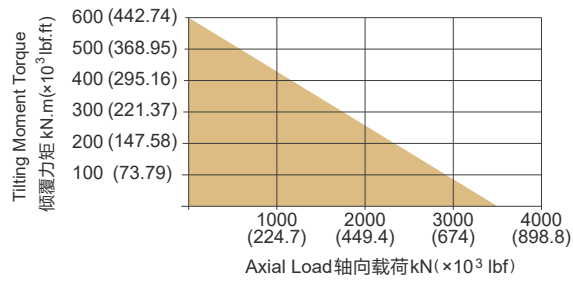

安装孔选项 Mounting Holes Option

Code 代码	M (Outer Ring 外圈)	N (Inner Ring 内圈)
—	M24×3 Tap (攻深)36	M24×3 Tap (攻深)36
T	M24×3 Tap (攻深)36	Ø26 Thru (通孔)
B	7/8"-9UNC-2B Tap (攻深)36	7/8"-9UNC-2B Tap (攻深)36
BT	7/8"-9UNC-2B Tap (攻深)36	Ø26 Thru (通孔)

性能参数表 Slewing Drive Performance Parameters

Output Torque	Tilting Moment Torque	Holding Torque	Static Axial Rating	Static Radial Rating	Dynamic Axial Rating	Dynamic Radial Rating	Gear Ratio	Tracking Precision	Weight
输出转矩	倾覆力矩	保持力矩	轴向静载荷	径向静载荷	轴向动载荷	径向动载荷	减速比	精度等级	重量
40 kN.m	600 kN.m	250 kN.m	3400 kN	1360 kN	850 kN	680 kN	110 : 1	≤ 0.15°	403kg
29516 lbf.ft	443×10³ lbf.ft	184×10³ lbf.ft	764×10³ lbf	306×10³ lbf	191×10³ lbf	152.8×10³ lbf			

"A" VIEW AS INPUT IS ALLOWED
输入端允许在“A”向视图

SPECIAL DESIGN BASE ON CUSTOMER'S REQUIREMENT
可根据顾客的要求进行非标设计

NOTICE
Please be sure to remain under the curve. 选型时请确保实际载荷在曲线范围内。
This drawing is just for your reference. 以上图纸仅供参考。
This drawing is subject to change due to new design without prior notice. 本公司保留改进产品的权利而不再另行通知。
Please contact the technical department for dimensions and performance parameters of the drives. 如果需要装置的外形尺寸和性能参数, 请与技术部门联系。

WEA7

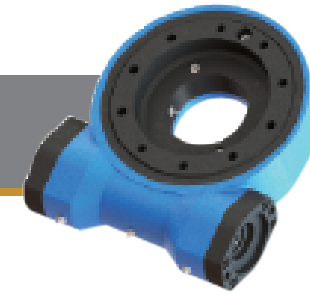

UNITS/单位:mm
1inch=25.4mm
Weight:35kg

FRONT VIEW
正视图

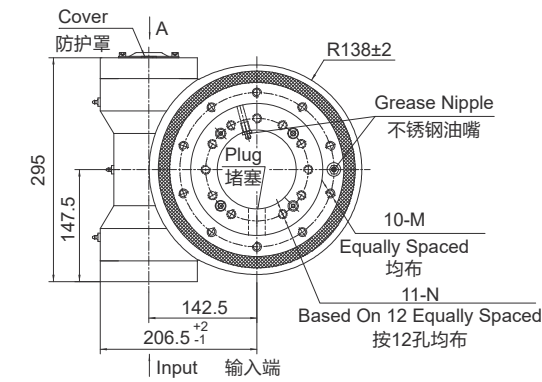

INPUT 输入端视图

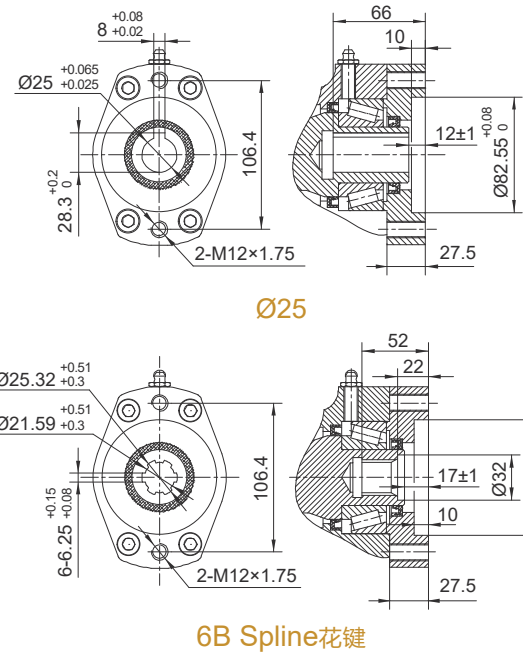

SIDE VIEW
侧视图

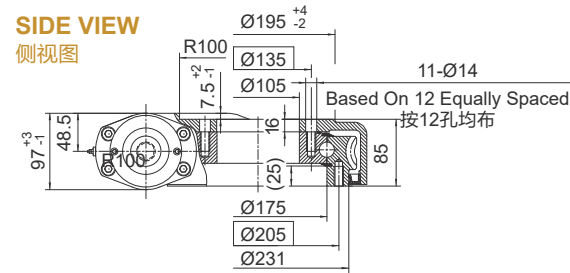

承载力矩图 MOMENT LOAD CHART

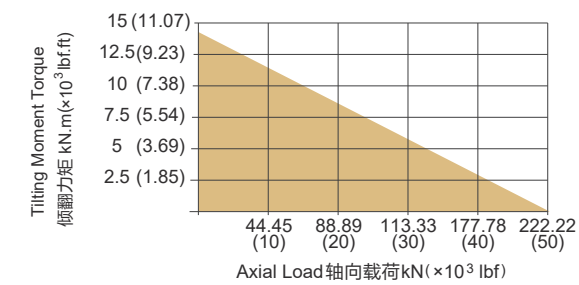

安装孔选项 Mounting Holes Option

Code 代码	M (Outer Ring 外圈)	N (Inner Ring 内圈)
—	M12×1.75 Tap (攻深)25	M12×1.75 Tap (攻深)25
T	M12×1.75 Tap (攻深)25	Ø14 Thru (通孔)
B	1/2"-13UNC-2B Tap (攻深)25	1/2"-13UNC-2B Tap (攻深)25
BT	1/2"-13UNC-2B Tap (攻深)25	Ø14 Thru (通孔)

性能参数表 Slewing Drive Performance Parameters

Output Torque	Tilting Moment Torque	Holding Torque	Static Axial Rating	Static Radial Rating	Dynamic Axial Rating	Dynamic Radial Rating	Gear Ratio	Tracking Precision	Weight
输出转矩	倾覆力矩	保持力矩	轴向静载荷	径向静载荷	轴向动载荷	径向动载荷	减速比	精度等级	重量
3.5 kN.m	14.2 kN.m	20 kN.m	220 kN	90 kN	63 kN	48 kN	47 : 1	≤ 0.15°	35kg
2583 lbf.ft	10.5×10³ lbf.ft	14.8×10³ lbf.ft	49.5×10³ lbf	20.2×10³ lbf	14.2×10³ lbf	10.8×10³ lbf			

"A" VIEW AS INPUT IS ALLOWED
输入端允许在“A”向视图

SPECIAL DESIGN BASE ON CUSTOMER'S REQUIREMENT
可根据顾客的要求进行非标设计

NOTICE
Please be sure to remain under the curve. 选型时请确保实际载荷在曲线范围内。
This drawing is just for your reference. 以上图纸仅供参考。
This drawing is subject to change due to new design without prior notice. 本公司保留改进产品的权利而不再另行通知。
Please contact the technical department for dimensions and performance parameters of the drives. 如果需要装置的外形尺寸和性能参数, 请与技术部门联系。

WEA9

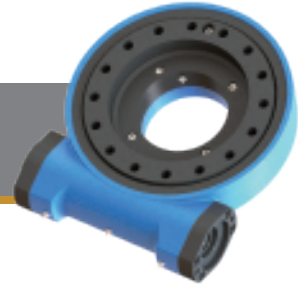

UNITS/单位:mm
1inch=25.4mm
Weight:53kg

FRONT VIEW
正视图

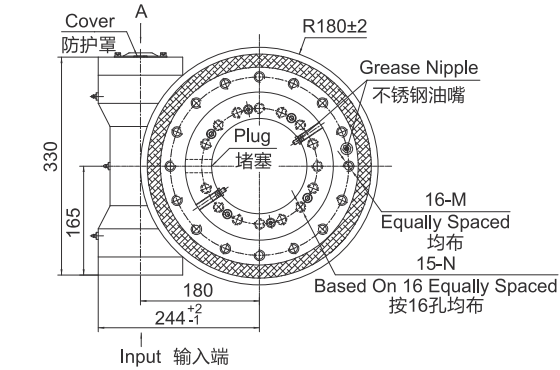

INPUT 输入端视图

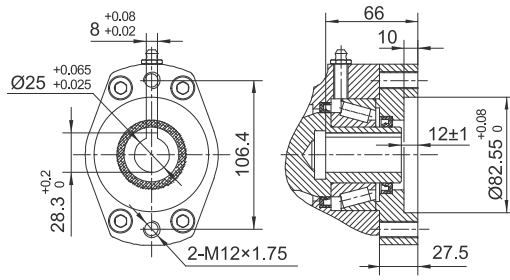

Ø25

SIDE VIEW
侧视图

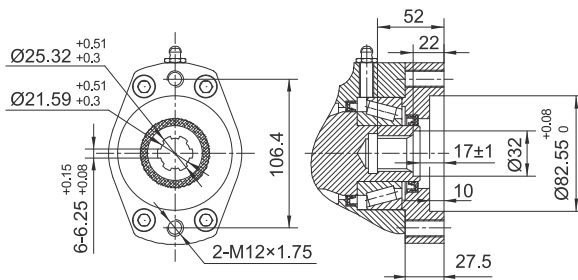
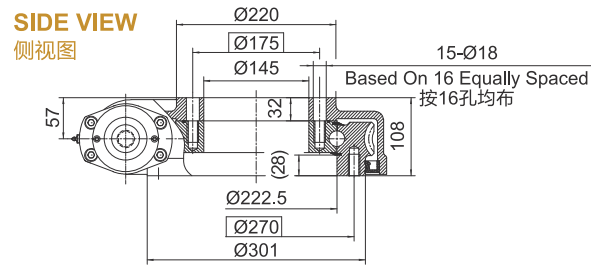

6B Spline花键

承载力矩图 MOMENT LOAD CHART

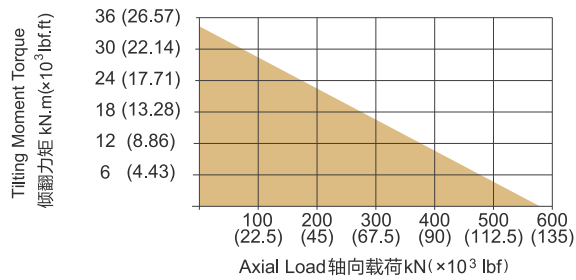

安装孔选项 Mounting Holes Option

Code 代码	M (Outer Ring 外圈)	N (Inner Ring 内圈)
—	M16×2 Tap (攻深)30	M16×2 Tap (攻深)30
T	M16×2 Tap (攻深)30	Ø18 Thru (通孔)
B	5/8"-11UNC-2B Tap (攻深)30	5/8"-11UNC-2B Tap (攻深)30
BT	5/8"-11UNC-2B Tap (攻深)30	Ø18 Thru (通孔)

性能参数表 Slewing Drive Performance Parameters

Output Torque	Tilting Moment Torque	Holding Torque	Static Axial Rating	Static Radial Rating	Dynamic Axial Rating	Dynamic Radial Rating	Gear Ratio	Tracking Precision	Weight
输出转矩	倾覆力矩	保持力矩	轴向静载荷	径向静载荷	轴向动载荷	径向动载荷	减速比	精度等级	重量
8 kN.m	35.6 kN.m	34.5 kN.m	578 kN	215 kN	136 kN	115 kN	62 : 1	≤ 0.15°	53kg
5904 lbf.ft	26.3×10³ lbf.ft	25.5×10³ lbf.ft	129.9×10³ lbf	48.3×10³ lbf	30.6×10³ lbf	25.9×10³ lbf			

"A" VIEW AS INPUT IS ALLOWED
输入端允许在“A”向视图

SPECIAL DESIGN BASE ON CUSTOMER'S REQUIREMENT
可根据顾客的要求进行非标设计

- NOTICE 注意**
- Please be sure to remain under the curve. 选型时请确保实际载荷在曲线范围内。
 - This drawing is just for your reference. 以上图纸仅供参考。
 - This drawing is subject to change due to new design without prior notice. 本公司保留改进产品的权利而不再另行通知。
 - Please contact the technical department for dimensions and performance parameters of the drives. 如果需要装置的外形尺寸和性能参数, 请与技术部门联系。

WEA12

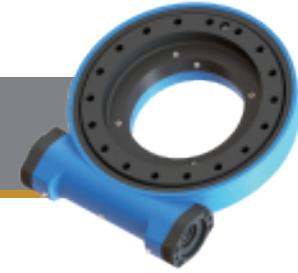

UNITS/单位:mm
1inch=25.4mm
Weight:66.8kg

FRONT VIEW
正视图

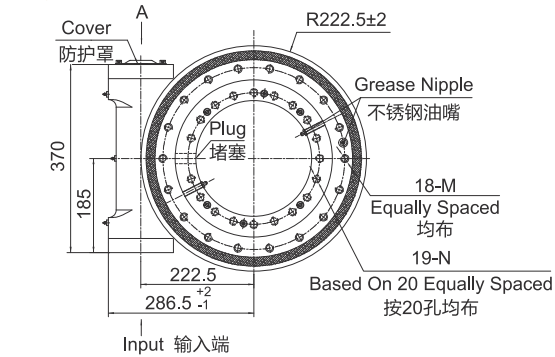

INPUT 输入端视图

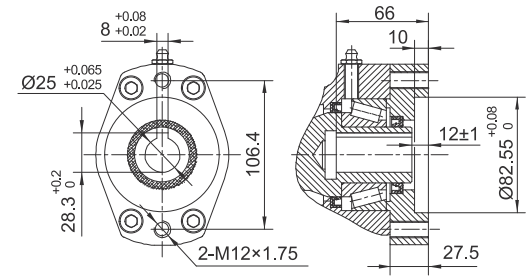

Ø25

SIDE VIEW
侧视图

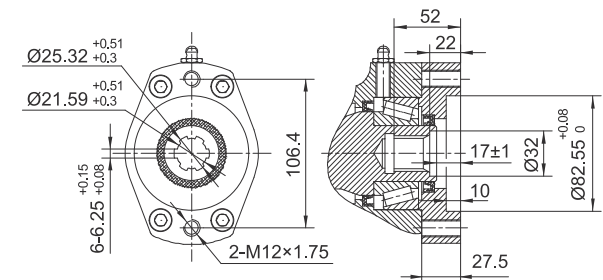
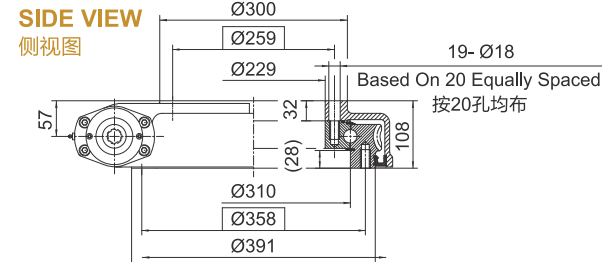

6B Spline花键

承载力矩图 MOMENT LOAD CHART

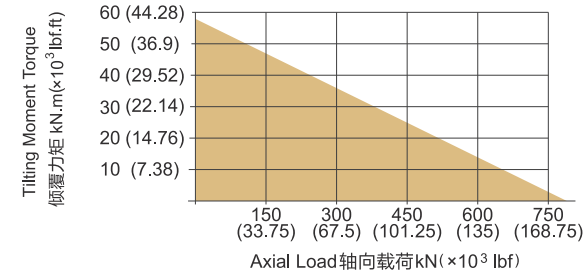

安装孔选项 Mounting Holes Option

Code 代码	M (Outer Ring 外圈)	N (Inner Ring 内圈)
—	M16×2 Tap (攻深)30	M16×2 Tap (攻深)30
T	M16×2 Tap (攻深)30	Ø18 Thru (通孔)
B	5/8"-11UNC-2B Tap (攻深)30	5/8"-11UNC-2B Tap (攻深)30
BT	5/8"-11UNC-2B Tap (攻深)30	Ø18 Thru (通孔)

性能参数表 Slewing Drive Performance Parameters

Output Torque	Tilting Moment Torque	Holding Torque	Static Axial Rating	Static Radial Rating	Dynamic Axial Rating	Dynamic Radial Rating	Gear Ratio	Tracking Precision	Weight
输出转矩	倾覆力矩	保持力矩	轴向静载荷	径向静载荷	轴向动载荷	径向动载荷	减速比	精度等级	重量
9.5 kN.m	57 kN.m	43 kN.m	760 kN	280 kN	190 kN	148 kN	79 : 1	≤ 0.15°	66.8kg
7011 lbf.ft	42.1×10³ lbf.ft	32×10³ lbf.ft	171.1×10³ lbf	62.9×10³ lbf	42.7×10³ lbf	33.3×10³ lbf			

"A" VIEW AS INPUT IS ALLOWED
输入端允许在“A”向视图

SPECIAL DESIGN BASE ON CUSTOMER'S REQUIREMENT
可根据顾客的要求进行非标设计

- NOTICE 注意**
- Please be sure to remain under the curve. 选型时请确保实际载荷在曲线范围内。
 - This drawing is just for your reference. 以上图纸仅供参考。
 - This drawing is subject to change due to new design without prior notice. 本公司保留改进产品的权利而不再另行通知。
 - Please contact the technical department for dimensions and performance parameters of the drives. 如果需要装置的外形尺寸和性能参数, 请与技术部门联系。

WEA14

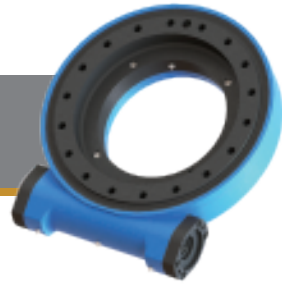

UNITS/单位:mm
1inch=25.4mm
Weight:75kg

FRONT VIEW
正视图

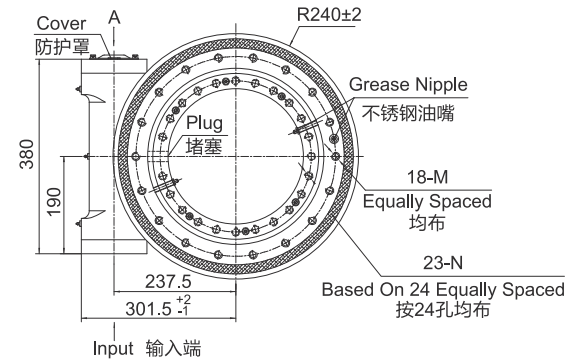

SIDE VIEW
侧视图

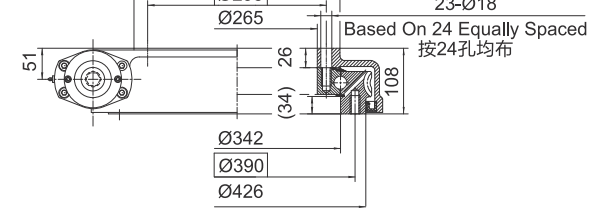

INPUT 输入端视图

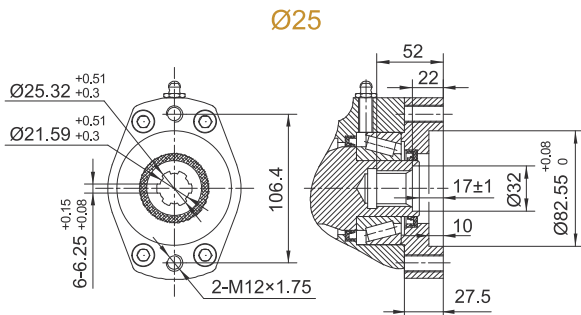
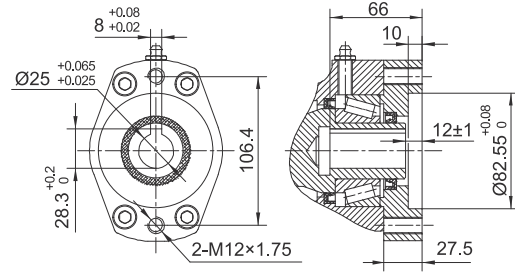

6B Spline花键

承载力矩图 MOMENT LOAD CHART

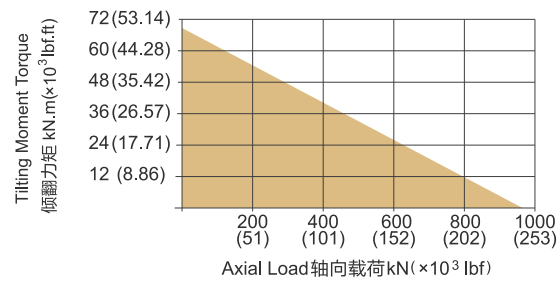

安装孔选项 Mounting Holes Option

Code 代码	M (Outer Ring 外圈)	N (Inner Ring 内圈)
—	M16×2 Tap (攻深)30	M16×2 Tap (攻深)30
T	M16×2 Tap (攻深)30	Ø18 Thru (通孔)
B	5/8"-11UNC-2B Tap (攻深)30	5/8"-11UNC-2B Tap (攻深)30
BT	5/8"-11UNC-2B Tap (攻深)30	Ø18 Thru (通孔)

性能参数表 Slewing Drive Performance Parameters

Output Torque	Tilting Moment Torque	Holding Torque	Static Axial Rating	Static Radial Rating	Dynamic Axial Rating	Dynamic Radial Rating	Gear Ratio	Tracking Precision	Weight
10.8 kN.m	71.2 kN.m	48 kN.m	960 kN	360 kN	230 kN	200 kN	86 : 1	≤ 0.13°	75kg
7970 lbf.ft	52.6×10 ³ lbf.ft	35×10 ³ lbf.ft	215.8×10 ³ lbf	80.9×10 ³ lbf	51.7×10 ³ lbf	44.9×10 ³ lbf			

"A" VIEW AS INPUT IS ALLOWED
输入端允许在“A”向视图

SPECIAL DESIGN BASE ON CUSTOMER'S REQUIREMENT
可根据顾客的要求进行非标设计

- NOTICE 注意**
- Please be sure to remain under the curve. 选型时请确保实际载荷在曲线范围内。
 - This drawing is just for your reference. 以上图纸仅供参考。
 - This drawing is subject to change due to new design without prior notice. 本公司保留改进产品的权利而不再另行通知。
 - Please contact the technical department for dimensions and performance parameters of the drives. 如果需要装置的外形尺寸和性能参数, 请与技术部门联系。

WEA14-2

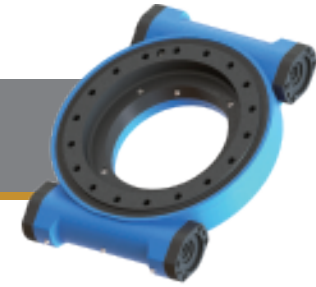

UNITS/单位:mm
1inch=25.4mm
Weight:90kg

FRONT VIEW
正视图

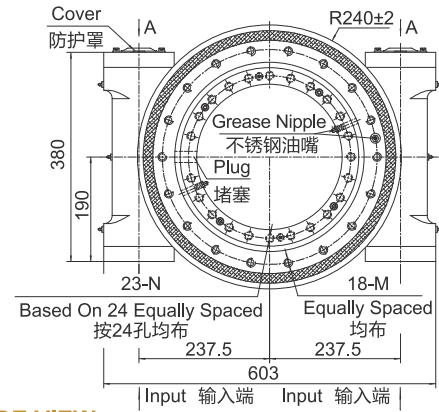

SIDE VIEW
侧视图

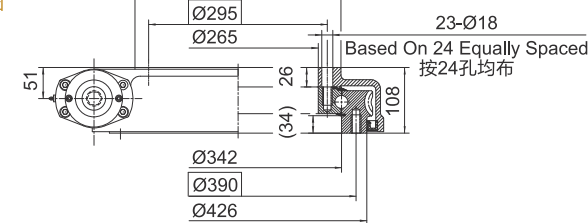

INPUT 输入端视图

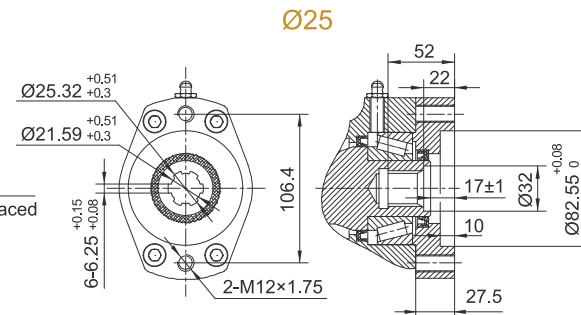
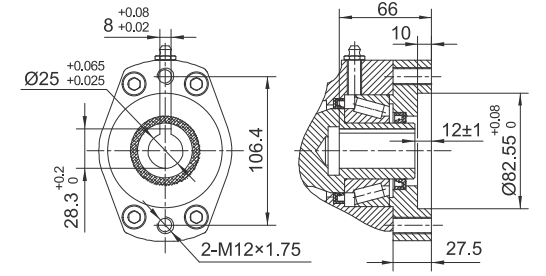

6B Spline花键

承载力矩图 MOMENT LOAD CHART

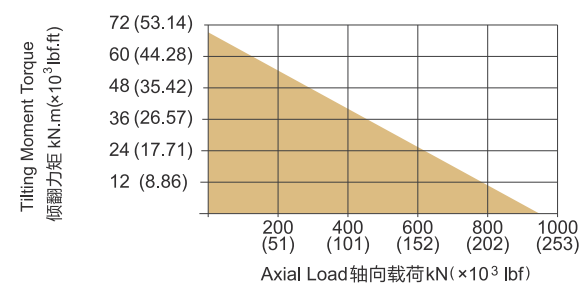

安装孔选项 Mounting Holes Option

Code 代码	M (Outer Ring 外圈)	N (Inner Ring 内圈)
—	M16×2 Tap (攻深)30	M16×2 Tap (攻深)30
T	M16×2 Tap (攻深)30	Ø18 Thru (通孔)
B	5/8"-11UNC-2B Tap (攻深)30	5/8"-11UNC-2B Tap (攻深)30
BT	5/8"-11UNC-2B Tap (攻深)30	Ø18 Thru (通孔)

性能参数表 Slewing Drive Performance Parameters

Output Torque	Tilting Moment Torque	Holding Torque	Static Axial Rating	Static Radial Rating	Dynamic Axial Rating	Dynamic Radial Rating	Gear Ratio	Tracking Precision	Weight
16.2 kN.m	71.2 kN.m	82 kN.m	960 kN	360 kN	230 kN	200 kN	86 : 1	≤ 0.15°	90 kg
11956 lbf.ft	52.6×10 ³ lbf.ft	60.5×10 ³ lbf.ft	215.8×10 ³ lbf	80.9×10 ³ lbf	51.7×10 ³ lbf	44.9×10 ³ lbf			

"A" VIEW AS INPUT IS ALLOWED
输入端允许在“A”向视图

SPECIAL DESIGN BASE ON CUSTOMER'S REQUIREMENT
可根据顾客的要求进行非标设计

- NOTICE 注意**
- Please be sure to remain under the curve. 选型时请确保实际载荷在曲线范围内。
 - This drawing is just for your reference. 以上图纸仅供参考。
 - This drawing is subject to change due to new design without prior notice. 本公司保留改进产品的权利而不再另行通知。
 - Please contact the technical department for dimensions and performance parameters of the drives. 如果需要装置的外形尺寸和性能参数, 请与技术部门联系。

WEA15



UNITS/单位:mm
1inch=25.4mm
Weight:66kg

FRONT VIEW
正视图

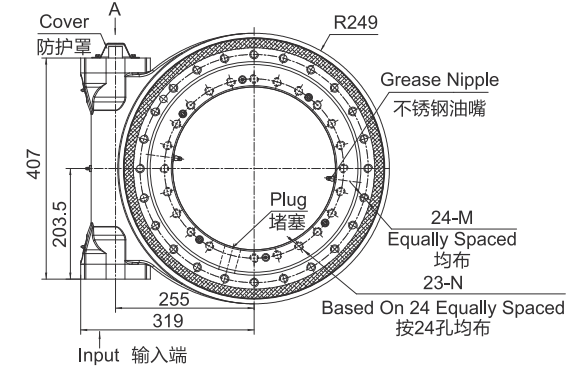

SIDE VIEW
侧视图

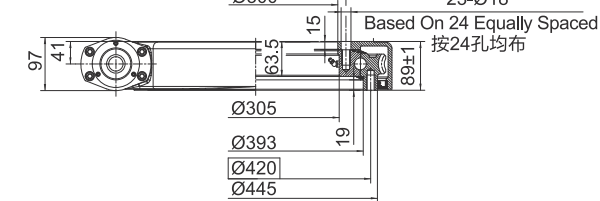

INPUT 输入端视图

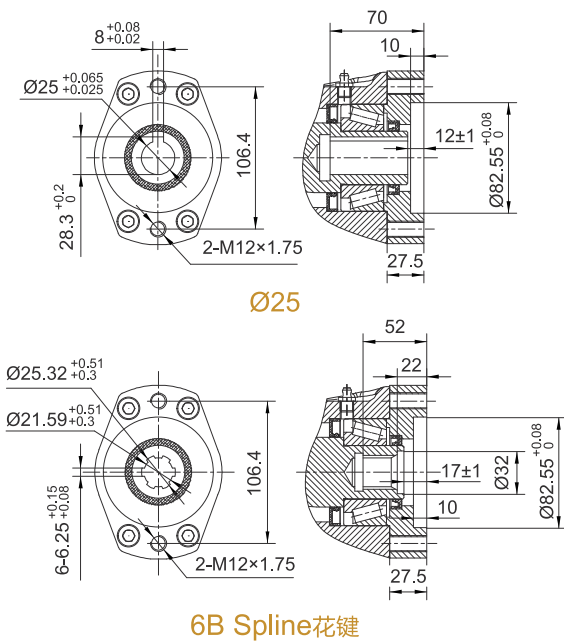

承载力矩图 MOMENT LOAD CHART

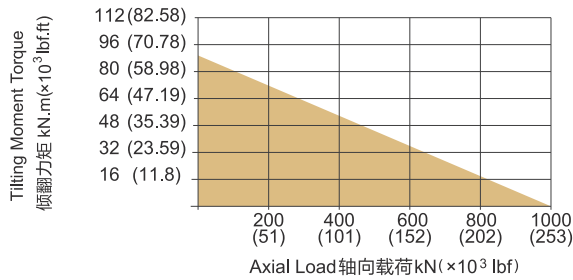

安装孔选项 Mounting Holes Option

Code 代码	M (Outer Ring 外圈)	N (Inner Ring 内圈)
—	M16×2 Tap (攻深)28	M16×2 Tap (攻深)28
T	M16×2 Tap (攻深)28	Ø17 Thru (通孔)
B	5/8"-11UNC-2B Tap (攻深)28	5/8"-11UNC-2B Tap (攻深)28
BT	5/8"-11UNC-2B Tap (攻深)28	Ø17 Thru (通孔)

性能参数表 Slewing Drive Performance Parameters

Output Torque	Tilting Moment Torque	Holding Torque	Static Axial Rating	Static Radial Rating	Dynamic Axial Rating	Dynamic Radial Rating	Gear Ratio	Tracking Precision	Weight
输出转矩	倾覆力矩	保持力矩	轴向静载荷	径向静载荷	轴向动载荷	径向动载荷	减速比	精度等级	重量
12 kN.m	90 kN.m	50 kN.m	1000 kN	400 kN	240 kN	220 kN	92 : 1	≤ 0.1°	66 kg
8856 lbf.ft	66×10³ lbf.ft	37×10³ lbf.ft	224.8×10³ lbf	89.9×10³ lbf	54.0×10³ lbf	49.5×10³ lbf			

"A" VIEW AS INPUT IS ALLOWED
输入端允许在 "A" 向视图

SPECIAL DESIGN BASE ON CUSTOMER'S REQUIREMENT
可根据顾客的要求进行非标设计

- Please be sure to remain under the curve. 选型时请确保实际载荷在曲线范围内。
- This drawing is just for your reference. 以上图纸仅供参考。
- This drawing is subject to change due to new design without prior notice. 本公司保留改进产品的权利而不再另行通知。
- Please contact the technical department for dimensions and performance parameters of the drives. 如果需要装置的外形尺寸和性能参数, 请与技术部门联系。

WEA17

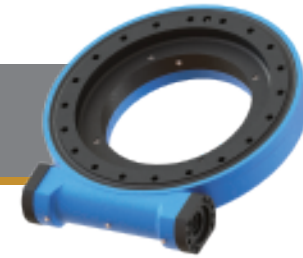

UNITS/单位:mm
1inch=25.4mm
Weight:96kg

FRONT VIEW
正视图

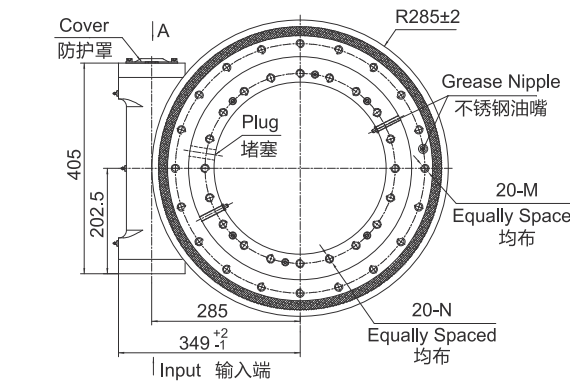

SIDE VIEW
侧视图

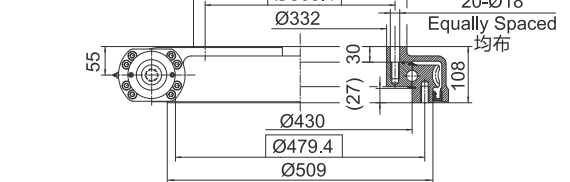

INPUT 输入端视图

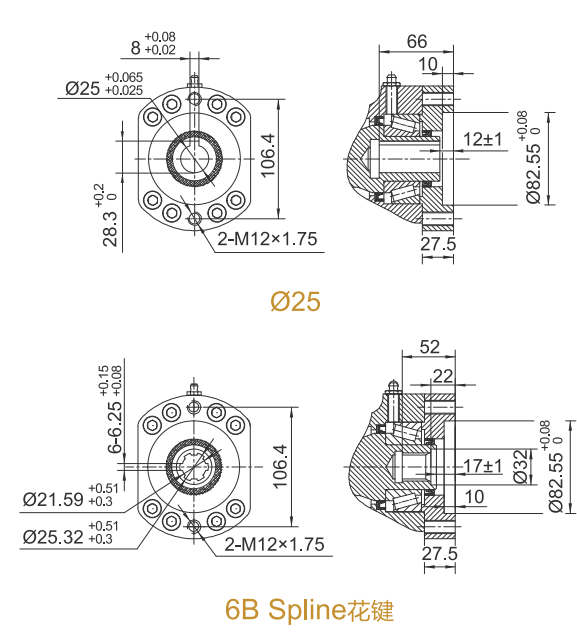

承载力矩图 MOMENT LOAD CHART

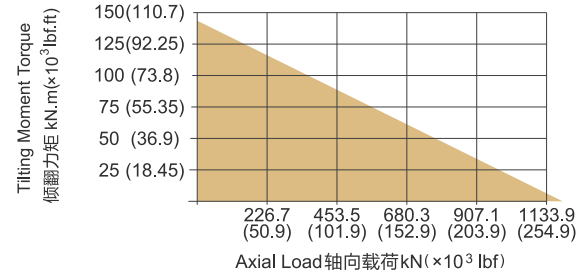

安装孔选项 Mounting Holes Option

Code 代码	M (Outer Ring 外圈)	N (Inner Ring 内圈)
—	M16×2 Tap (攻深)32	M16×2 Tap (攻深)32
T	M16×2 Tap (攻深)32	Ø18 Thru (通孔)
B	5/8"-11UNC-2B Tap (攻深)32	5/8"-11UNC-2B Tap (攻深)32
BT	5/8"-11UNC-2B Tap (攻深)32	Ø18 Thru (通孔)

性能参数表 Slewing Drive Performance Parameters

Output Torque	Tilting Moment Torque	Holding Torque	Static Axial Rating	Static Radial Rating	Dynamic Axial Rating	Dynamic Radial Rating	Gear Ratio	Tracking Precision	Weight
输出转矩	倾覆力矩	保持力矩	轴向静载荷	径向静载荷	轴向动载荷	径向动载荷	减速比	精度等级	重量
12.96 kN.m	142.4 kN.m	72.3 kN.m	1166 kN	435 kN	280 kN	231 kN	104 : 1	≤ 0.1°	96 kg
9564 lbf.ft	105×10³ lbf.ft	53.4×10³ lbf.ft	262×10³ lbf	97.8×10³ lbf	62.9×10³ lbf	51.9×10³ lbf			

"A" VIEW AS INPUT IS ALLOWED
输入端允许在 "A" 向视图

SPECIAL DESIGN BASE ON CUSTOMER'S REQUIREMENT
可根据顾客的要求进行非标设计

- Please be sure to remain under the curve. 选型时请确保实际载荷在曲线范围内。
- This drawing is just for your reference. 以上图纸仅供参考。
- This drawing is subject to change due to new design without prior notice. 本公司保留改进产品的权利而不再另行通知。
- Please contact the technical department for dimensions and performance parameters of the drives. 如果需要装置的外形尺寸和性能参数, 请与技术部门联系。

WEA17-2

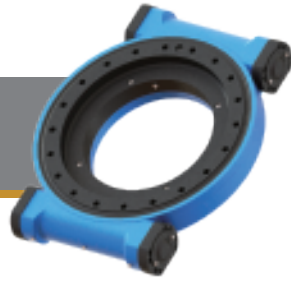

UNITS/单位:mm
1inch=25.4mm
Weight:120kg

FRONT VIEW
正视图

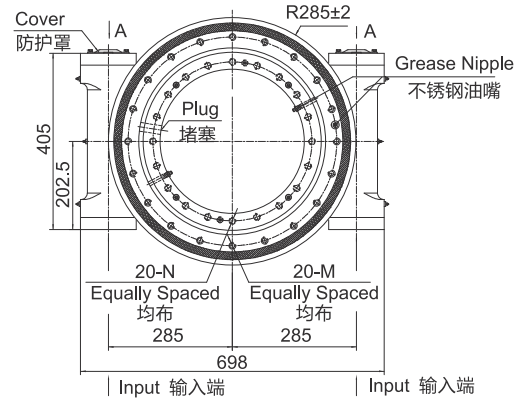

INPUT 输入端视图

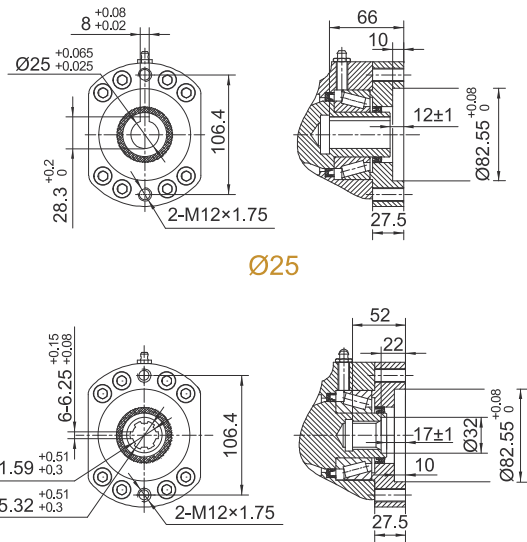

SIDE VIEW
侧视图

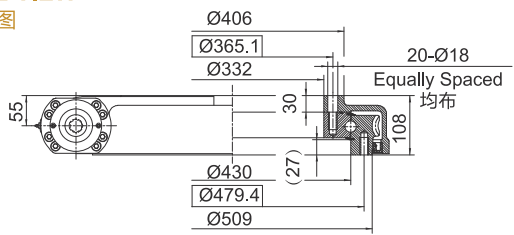

6B Spline花键

承载力矩图 MOMENT LOAD CHART

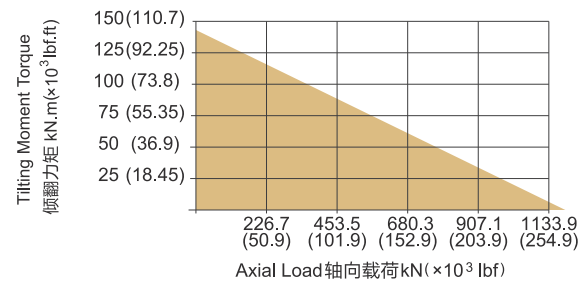

安装孔选项 Mounting Holes Option

Code 代码	M (Outer Ring 外圈)	N (Inner Ring 内圈)
—	M16×2 Tap (攻深)32	M16×2 Tap (攻深)32
T	M16×2 Tap (攻深)32	Ø18 Thru (通孔)
B	5/8"-11UNC-2B Tap (攻深)32	5/8"-11UNC-2B Tap (攻深)32
BT	5/8"-11UNC-2B Tap (攻深)32	Ø18 Thru (通孔)

性能参数表 Slewing Drive Performance Parameters

Output Torque	Tilting Moment Torque	Holding Torque	Static Axial Rating	Static Radial Rating	Dynamic Axial Rating	Dynamic Radial Rating	Gear Ratio	Tracking Precision	Weight
19.44 kN.m	142.4 kN.m	94 kN.m	1166 kN	435 kN	280 kN	231 kN	104 : 1	≤ 0.15°	120 kg
14347 lbf.ft	105.1×10 ³ lbf.ft	53.4×10 ³ lbf.ft	262×10 ³ lbf	97.8×10 ³ lbf	62.9×10 ³ lbf	51.9×10 ³ lbf			

"A" VIEW AS INPUT IS ALLOWED
输入端允许在“A”向视图

SPECIAL DESIGN BASE ON CUSTOMER'S REQUIREMENT
可根据顾客的要求进行非标设计

- Please be sure to remain under the curve. 选型时请确保实际载荷在曲线范围内。
- This drawing is just for your reference. 以上图纸仅供参考。
- This drawing is subject to change due to new design without prior notice. 本公司保留改进产品的权利而不再另行通知。
- Please contact the technical department for dimensions and performance parameters of the drives. 如果需要装置的外形尺寸和性能参数, 请与技术部门联系。

WEA19B

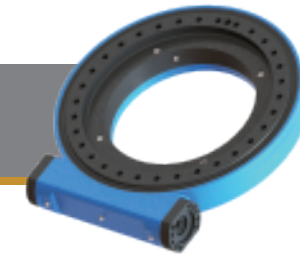

UNITS/单位:mm
1inch=25.4mm
Weight:118kg

FRONT VIEW
正视图

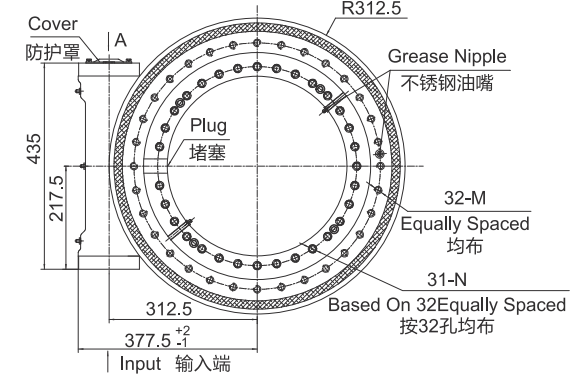

INPUT 输入端视图

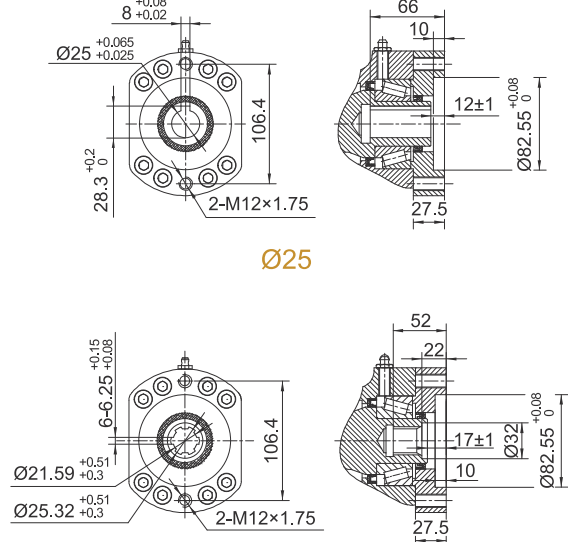

SIDE VIEW
侧视图

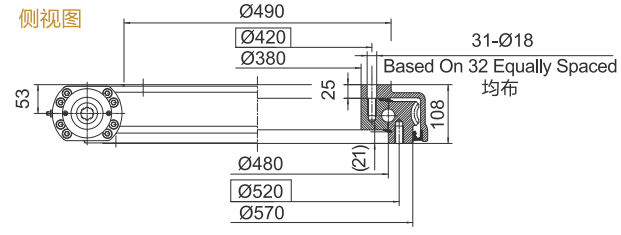

6B Spline花键

承载力矩图 MOMENT LOAD CHART

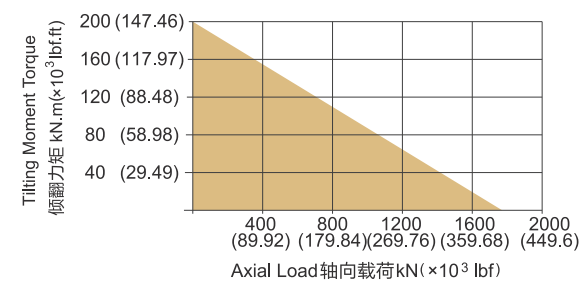

安装孔选项 Mounting Holes Option

Code 代码	M (Outer Ring 外圈)	N (Inner Ring 内圈)
—	M16×2 Tap (攻深)32	M16×2 Tap (攻深)32
T	M16×2 Tap (攻深)32	Ø18 Thru (通孔)
B	5/8"-11UNC-2B Tap (攻深)32	5/8"-11UNC-2B Tap (攻深)32
BT	5/8"-11UNC-2B Tap (攻深)32	Ø18 Thru (通孔)

性能参数表 Slewing Drive Performance Parameters

Output Torque	Tilting Moment Torque	Holding Torque	Static Axial Rating	Static Radial Rating	Dynamic Axial Rating	Dynamic Radial Rating	Gear Ratio	Tracking Precision	Weight
18.5 kN.m	196 kN.m	80.1 kN.m	1800 kN	675 kN	290 kN	250 kN	94 : 1	≤ 0.1°	118 kg
13653 lbf.ft	144.6×10 ³ lbf.ft	59.1×10 ³ lbf.ft	404.6×10 ³ lbf	151.7×10 ³ lbf	65.2×10 ³ lbf	56.2×10 ³ lbf			

"A" VIEW AS INPUT IS ALLOWED
输入端允许在“A”向视图

SPECIAL DESIGN BASE ON CUSTOMER'S REQUIREMENT
可根据顾客的要求进行非标设计

- Please be sure to remain under the curve. 选型时请确保实际载荷在曲线范围内。
- This drawing is just for your reference. 以上图纸仅供参考。
- This drawing is subject to change due to new design without prior notice. 本公司保留改进产品的权利而不再另行通知。
- Please contact the technical department for dimensions and performance parameters of the drives. 如果需要装置的外形尺寸和性能参数, 请与技术部门联系。

WEA21

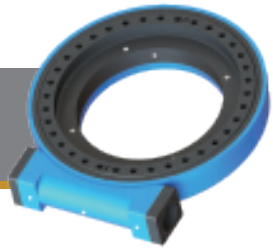

UNITS/单位:mm
1inch=25.4mm
Weight:172kg

FRONT VIEW
正视图

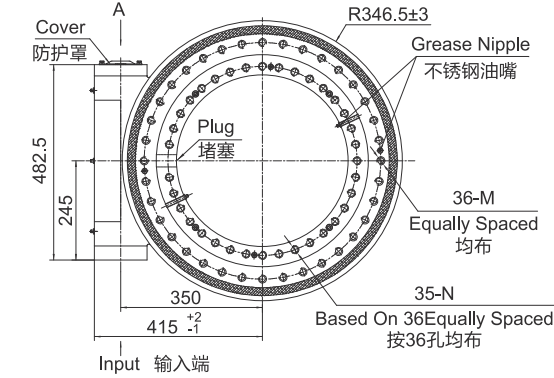

INPUT 输入端视图

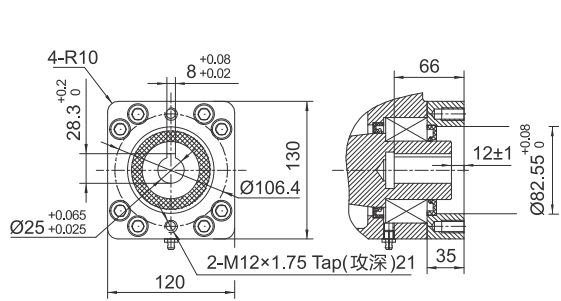

SIDE VIEW
侧视图

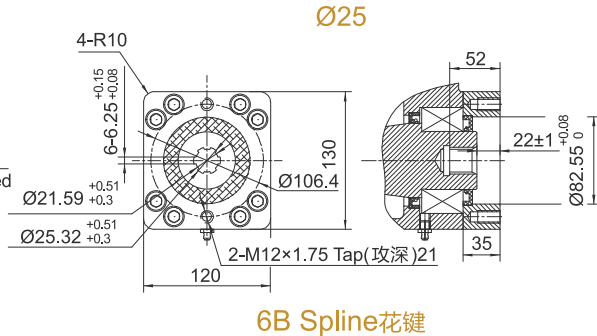
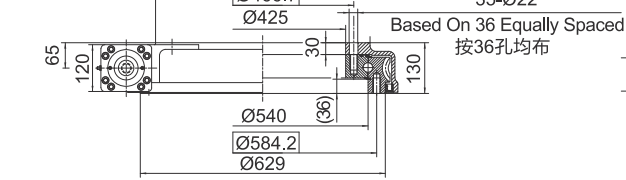

6B Spline花键

承载力矩图 MOMENT LOAD CHART

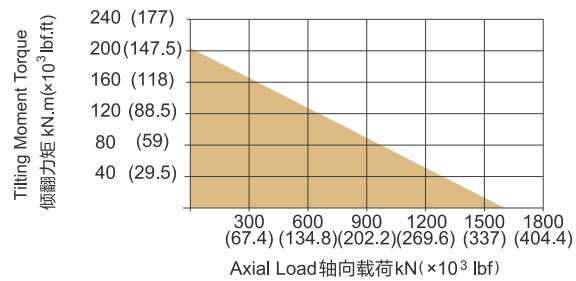

安装孔选项 Mounting Holes Option

Code 代码	M (Outer Ring 外圈)	N (Inner Ring 内圈)
—	M20×2.5 Tap (攻深)40	M20×2.5 Tap (攻深)40
T	M20×2.5 Tap (攻深)40	Ø22 Thru (通孔)
B	3/4"-10UNC-2B Tap (攻深)40	3/4"-10UNC-2B Tap (攻深)40
BT	3/4"-10UNC-2B Tap (攻深)40	Ø22 Thru (通孔)

性能参数表 Slewing Drive Performance Parameters

Output Torque	Tilting Moment Torque	Holding Torque	Static Axial Rating	Static Radial Rating	Dynamic Axial Rating	Dynamic Radial Rating	Gear Ratio	Tracking Precision	Weight
输出转矩	倾覆力矩	保持力矩	轴向静载荷	径向静载荷	轴向动载荷	径向动载荷	减速比	精度等级	重量
28.7 kN.m	203 kN.m	105.8 kN.m	1598 kN	640 kN	385 kN	335 kN	90 : 1	≤ 0.1°	172 kg
21180 lbf.ft	150×10³ lbf.ft	78.1×10³ lbf.ft	359×10³ lbf	144×10³ lbf	87×10³ lbf	75×10³ lbf			

"A" VIEW AS INPUT IS ALLOWED
输入端允许在“A”向视图

SPECIAL DESIGN BASE ON CUSTOMER'S REQUIREMENT
可根据顾客的要求进行非标设计

NOTICE
Please be sure to remain under the curve. 选型时请确保实际载荷在曲线范围内。
This drawing is just for your reference. 以上图纸仅供参考。
This drawing is subject to change due to new design without prior notice. 本公司保留改进产品的权利而不再另行通知。
Please contact the technical department for dimensions and performance parameters of the drives. 如果需要装置的外形尺寸和性能参数, 请与技术部门联系。

WEA21-2

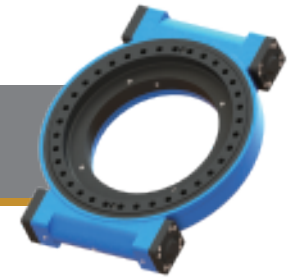

UNITS/单位:mm
1inch=25.4mm
Weight:200kg

FRONT VIEW
正视图

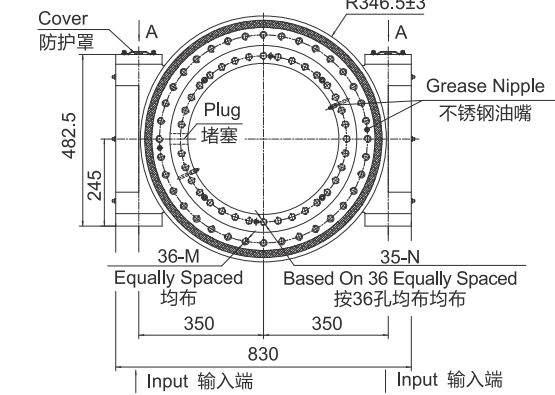

INPUT 输入端视图

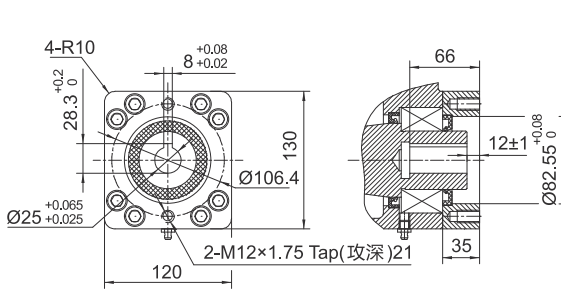

SIDE VIEW
侧视图

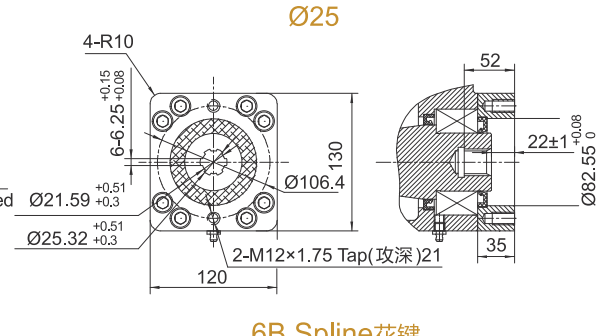
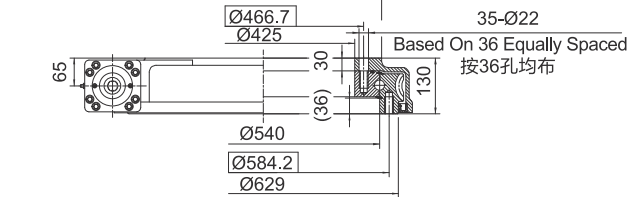

6B Spline花键

承载力矩图 MOMENT LOAD CHART

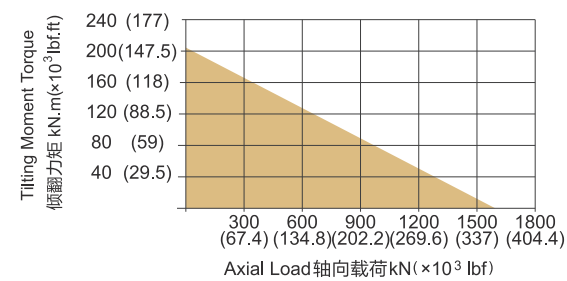

安装孔选项 Mounting Holes Option

Code 代码	M (Outer Ring 外圈)	N (Inner Ring 内圈)
—	M20×2.5 Tap (攻深)40	M20×2.5 Tap (攻深)40
T	M20×2.5 Tap (攻深)40	Ø22 Thru (通孔)
B	3/4"-10UNC-2B Tap (攻深)40	3/4"-10UNC-2B Tap (攻深)40
BT	3/4"-10UNC-2B Tap (攻深)40	Ø22 Thru (通孔)

性能参数表 Slewing Drive Performance Parameters

Output Torque	Tilting Moment Torque	Holding Torque	Static Axial Rating	Static Radial Rating	Dynamic Axial Rating	Dynamic Radial Rating	Gear Ratio	Tracking Precision	Weight
输出转矩	倾覆力矩	保持力矩	轴向静载荷	径向静载荷	轴向动载荷	径向动载荷	减速比	精度等级	重量
48 kN.m	203 kN.m	179.9 kN.m	1598 kN	640 kN	385 kN	335 kN	90 : 1	≤ 0.13°	200 kg
35400 lbf.ft	150×10³ lbf.ft	133×10³ lbf.ft	359×10³ lbf	144×10³ lbf	87×10³ lbf	75×10³ lbf			

"A" VIEW AS INPUT IS ALLOWED
输入端允许在“A”向视图

SPECIAL DESIGN BASE ON CUSTOMER'S REQUIREMENT
可根据顾客的要求进行非标设计

NOTICE
Please be sure to remain under the curve. 选型时请确保实际载荷在曲线范围内。
This drawing is just for your reference. 以上图纸仅供参考。
This drawing is subject to change due to new design without prior notice. 本公司保留改进产品的权利而不再另行通知。
Please contact the technical department for dimensions and performance parameters of the drives. 如果需要装置的外形尺寸和性能参数, 请与技术部门联系。

WEA25

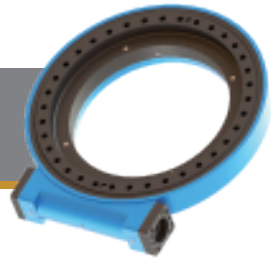

UNITS/单位:mm
1inch=25.4mm
Weight:202kg

FRONT VIEW 正视图

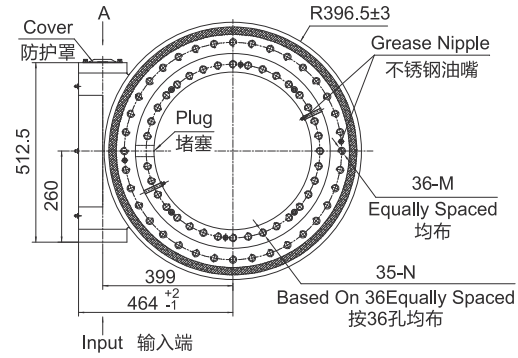

INPUT 输入端视图

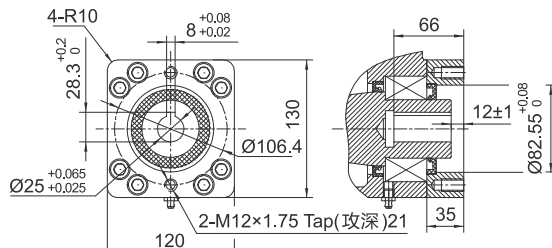

SIDE VIEW 侧视图

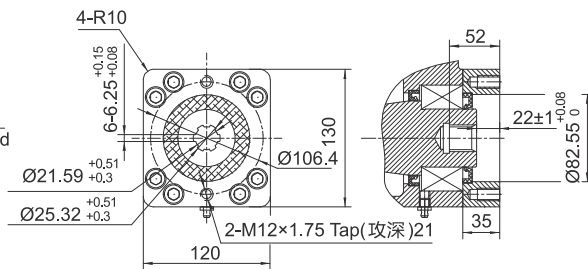
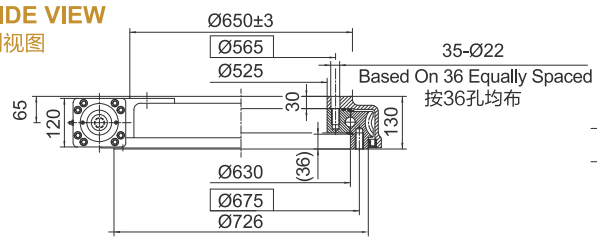

承载力矩图 MOMENT LOAD CHART

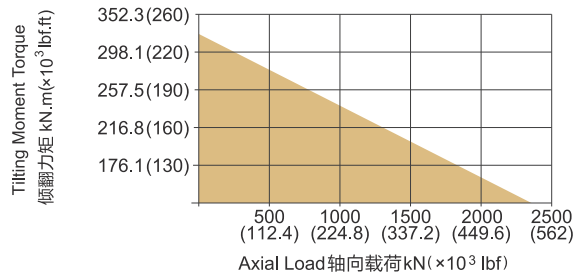

安装孔选项 Mounting Holes Option

Code 代码	M (Outer Ring 外圈)	N (Inner Ring 内圈)
—	M20×2.5 Tap (攻深)40	M20×2.5 Tap (攻深)40
T	M20×2.5 Tap (攻深)40	Ø22 Thru (通孔)
B	3/4"-10UNC-2B Tap (攻深)40	3/4"-10UNC-2B Tap (攻深)40
BT	3/4"-10UNC-2B Tap (攻深)40	Ø22 Thru (通孔)

性能参数表 Slewing Drive Performance Parameters

Output Torque	Tilting Moment Torque	Holding Torque	Static Axial Rating	Static Radial Rating	Dynamic Axial Rating	Dynamic Radial Rating	Gear Ratio	Tracking Precision	Weight
34.2 kN.m	310 kN.m	158.3 kN.m	2360 kN	945 kN	590 kN	470 kN	104 : 1	≤ 0.1°	202 kg
25240 lbf.ft	229×10³ lbf.ft	117×10³ lbf.ft	531×10³ lbf	212×10³ lbf	133×10³ lbf	106×10³ lbf			

"A" VIEW AS INPUT IS ALLOWED
输入端允许在 "A" 向视图

SPECIAL DESIGN BASE ON CUSTOMER'S REQUIREMENT
可根据顾客的要求进行非标设计

- Please be sure to remain under the curve. 选型时请确保实际载荷在曲线范围内。
- This drawing is just for your reference. 以上图纸仅供参考。
- This drawing is subject to change due to new design without prior notice. 本公司保留改进产品的权利而不再另行通知。
- Please contact the technical department for dimensions and performance parameters of the drives. 如果需要装置的外形尺寸和性能参数, 请与技术部门联系。

WEA25-2



UNITS/单位:mm
1inch=25.4mm
Weight:273kg

FRONT VIEW 正视图

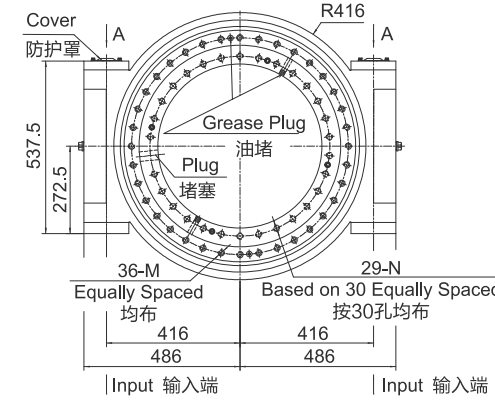

INPUT 输入端视图

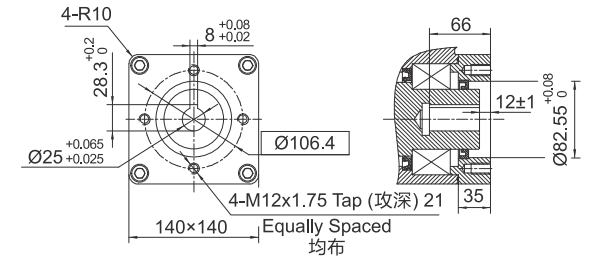

SIDE VIEW 侧视图

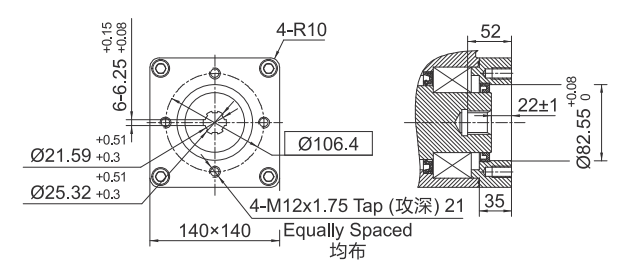
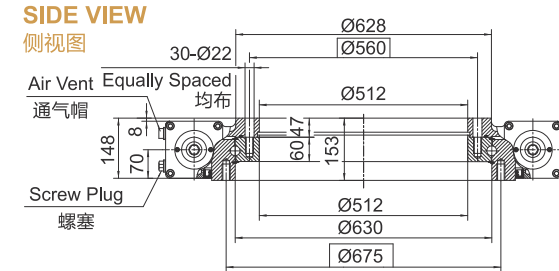

承载力矩图 MOMENT LOAD CHART

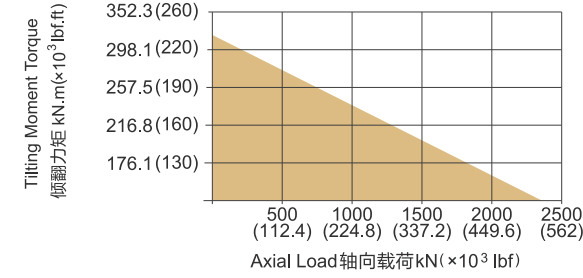

安装孔选项 Mounting Holes Option

Code 代码	M (Outer Ring 外圈)	N (Inner Ring 内圈)
—	M20×2.5 Tap (攻深)40	M20×2.5 Tap (攻深)40
T	M20×2.5 Tap (攻深)40	Ø22 Thru (通孔)
B	3/4"-10UNC-2B Tap (攻深)40	3/4"-10UNC-2B Tap (攻深)40
BT	3/4"-10UNC-2B Tap (攻深)40	Ø22 Thru (通孔)

性能参数表 Slewing Drive Performance Parameters

Output Torque	Tilting Moment Torque	Holding Torque	Static Axial Rating	Static Radial Rating	Dynamic Axial Rating	Dynamic Radial Rating	Gear Ratio	Tracking Precision	Weight
58 kN.m	310 kN.m	247 kN.m	2360 kN	945 kN	590 kN	470 kN	108 : 1	≤ 0.12°	273 kg
42800 lbf.ft	229×10³ lbf.ft	182.3×10³ lbf.ft	531×10³ lbf	212×10³ lbf	133×10³ lbf	106×10³ lbf			

"A" VIEW AS INPUT IS ALLOWED
输入端允许在 "A" 向视图

SPECIAL DESIGN BASE ON CUSTOMER'S REQUIREMENT
可根据顾客的要求进行非标设计

- Please be sure to remain under the curve. 选型时请确保实际载荷在曲线范围内。
- This drawing is just for your reference. 以上图纸仅供参考。
- This drawing is subject to change due to new design without prior notice. 本公司保留改进产品的权利而不再另行通知。
- Please contact the technical department for dimensions and performance parameters of the drives. 如果需要装置的外形尺寸和性能参数, 请与技术部门联系。

WEA28

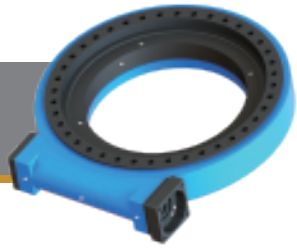

UNITS/单位:mm
1inch=25.4mm
Weight:418kg

FRONT VIEW
正视图

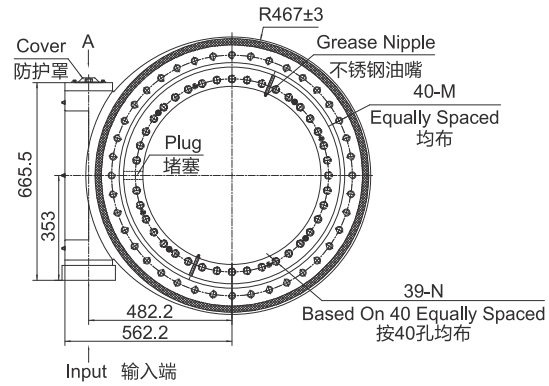

INPUT 输入端视图

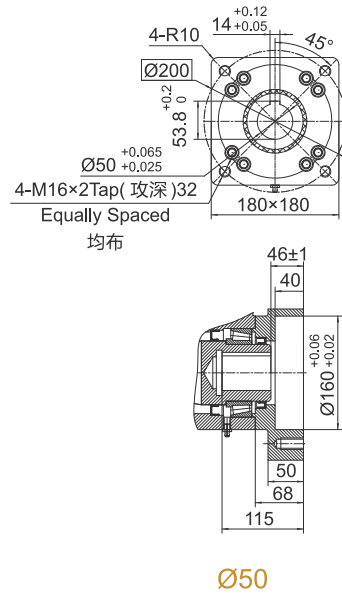

SIDE VIEW
侧视图

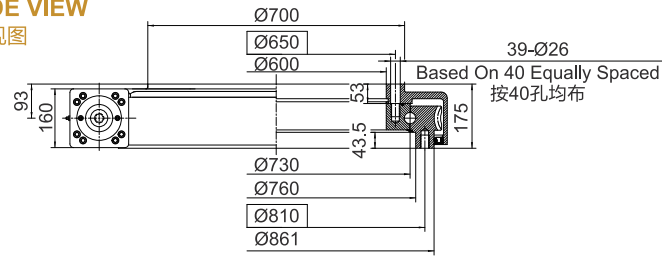

承载力矩图 MOMENT LOAD CHART

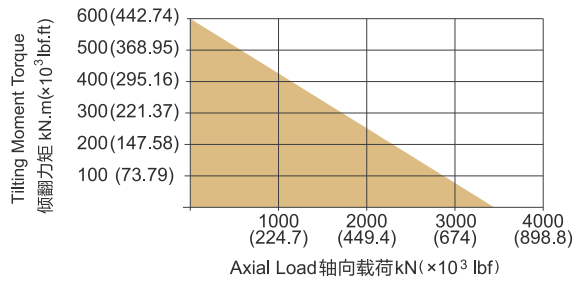

安装孔选项 Mounting Holes Option

Code 代码	M (Outer Ring 外圈)	N (Inner Ring 内圈)
—	M24×3 Tap (攻深)36	M24×3 Tap (攻深)36
T	M24×3 Tap (攻深)36	Ø26 Thru (通孔)
B	7/8"-9UNC-2B Tap (攻深)36	7/8"-9UNC-2B Tap (攻深)36
BT	7/8"-9UNC-2B Tap (攻深)36	Ø26 Thru (通孔)

性能参数表 Slewing Drive Performance Parameters

Output Torque	Tilting Moment Torque	Holding Torque	Static Axial Rating	Static Radial Rating	Dynamic Axial Rating	Dynamic Radial Rating	Gear Ratio	Tracking Precision	Weight
输出转矩	倾覆力矩	保持力矩	轴向静载荷	径向静载荷	轴向动载荷	径向动载荷	减速比	精度等级	重量
40 kN.m	600 kN.m	250 kN.m	3400 kN	1360 kN	850 kN	680 kN	110 : 1	≤ 0.15°	418 kg
29516 lbf.ft	443×10 ³ lbf.ft	184×10 ³ lbf.ft	764×10 ³ lbf	306×10 ³ lbf	191×10 ³ lbf	152.8×10 ³ lbf			

"A" VIEW AS INPUT IS ALLOWED
输入端允许在“A”向视图

SPECIAL DESIGN BASE ON CUSTOMER'S REQUIREMENT
可根据顾客的要求进行非标设计

NOTICE
Please be sure to remain under the curve. 选型时请确保实际载荷在曲线范围内。
This drawing is just for your reference. 以上图纸仅供参考。
This drawing is subject to change due to new design without prior notice. 本公司保留改进产品的权利而不再另行通知。
Please contact the technical department for dimensions and performance parameters of the drives. 如果需要装置的外形尺寸和性能参数, 请与技术部门联系。

WEB7

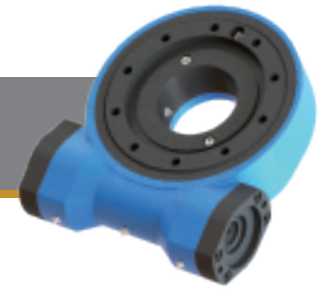

UNITS/单位:mm
1inch=25.4mm
Weight:37kg

FRONT VIEW
正视图

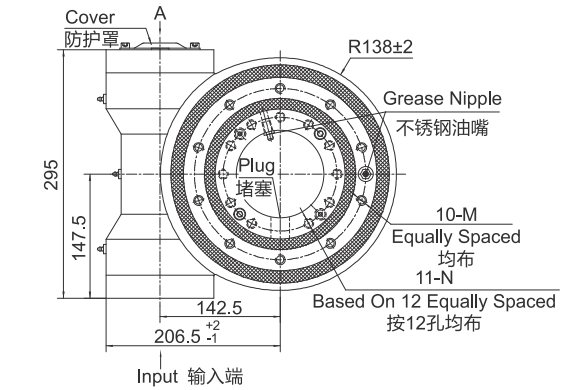

INPUT 输入端视图

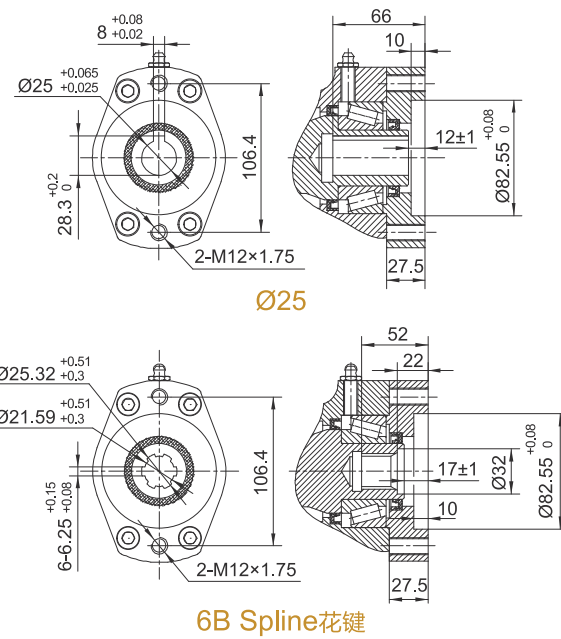

SIDE VIEW
侧视图

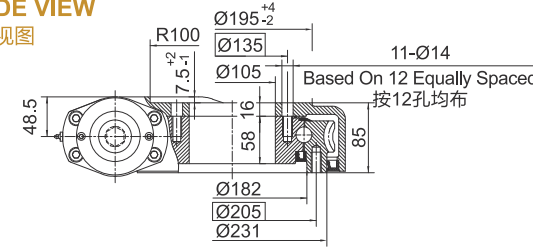

承载力矩图 MOMENT LOAD CHART

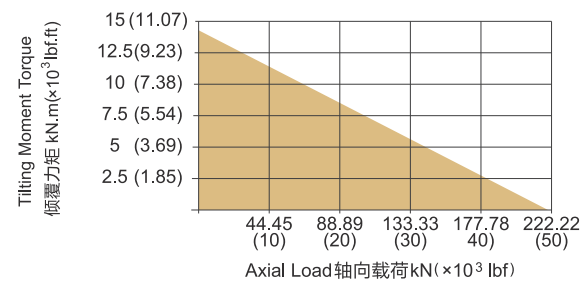

安装孔选项 Mounting Holes Option

Code 代码	M (Outer Ring 外圈)	N (Inner Ring 内圈)
—	M12×1.75 Tap (攻深)25	M12×1.75 Tap (攻深)25
T	M12×1.75 Tap (攻深)25	Ø14 Thru (通孔)
B	1/2"-13UNC-2B Tap (攻深)25	1/2"-13UNC-2B Tap (攻深)25
BT	1/2"-13UNC-2B Tap (攻深)25	Ø14 Thru (通孔)

性能参数表 Slewing Drive Performance Parameters

Output Torque	Tilting Moment Torque	Holding Torque	Static Axial Rating	Static Radial Rating	Dynamic Axial Rating	Dynamic Radial Rating	Gear Ratio	Tracking Precision	Weight
输出转矩	倾覆力矩	保持力矩	轴向静载荷	径向静载荷	轴向动载荷	径向动载荷	减速比	精度等级	重量
3.5 kN.m	14.2 kN.m	20 kN.m	220 kN	90 kN	63 kN	48 kN	47 : 1	≤ 0.15°	37kg
2583 lbf.ft	10.5×10 ³ lbf.ft	14.8×10 ³ lbf.ft	49.5×10 ³ lbf	20.2×10 ³ lbf	14.2×10 ³ lbf	10.8×10 ³ lbf			

"A" VIEW AS INPUT IS ALLOWED
输入端允许在“A”向视图

SPECIAL DESIGN BASE ON CUSTOMER'S REQUIREMENT
可根据顾客的要求进行非标设计

NOTICE
Please be sure to remain under the curve. 选型时请确保实际载荷在曲线范围内。
This drawing is just for your reference. 以上图纸仅供参考。
This drawing is subject to change due to new design without prior notice. 本公司保留改进产品的权利而不再另行通知。
Please contact the technical department for dimensions and performance parameters of the drives. 如果需要装置的外形尺寸和性能参数, 请与技术部门联系。

WEB9

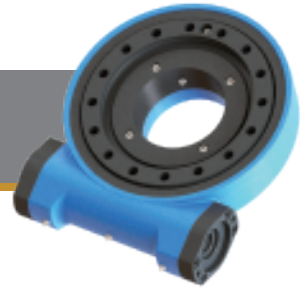

UNITS/单位:mm
1inch=25.4mm
Weight:54kg

FRONT VIEW
正视图

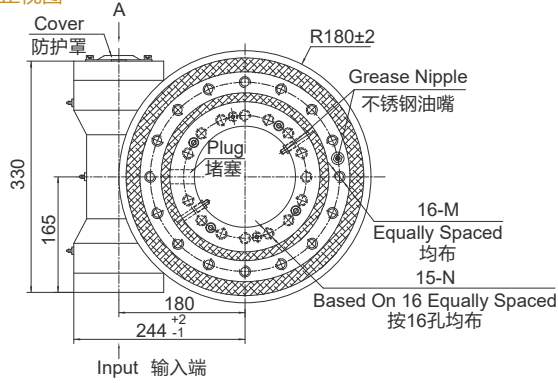

SIDE VIEW
侧视图

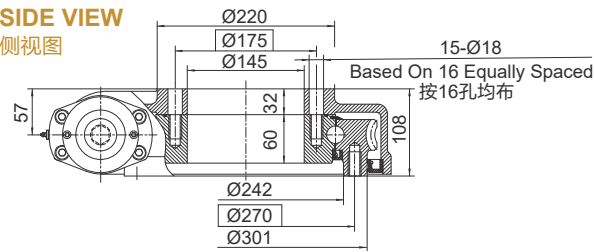

INPUT 输入端视图

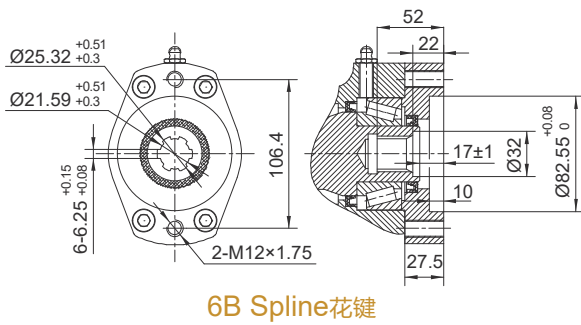
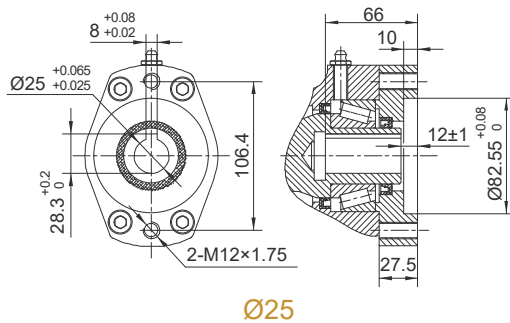

承载力矩图 MOMENT LOAD CHART

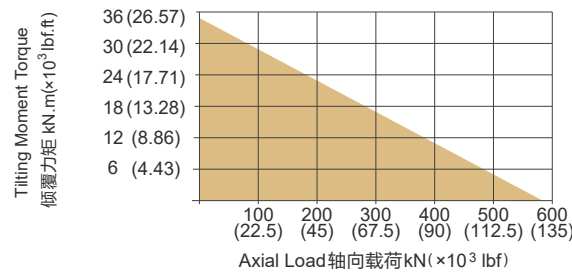

安装孔选项 Mounting Holes Option

Code 代码	M (Outer Ring 外圈)	N (Inner Ring 内圈)
—	M16×2 Tap (攻深)30	M16×2 Tap (攻深)30
T	M16×2 Tap (攻深)30	Ø18 Thru (通孔)
B	5/8"-11UNC-2B Tap (攻深)30	5/8"-11UNC-2B Tap (攻深)30
BT	5/8"-11UNC-2B Tap (攻深)30	Ø18 Thru (通孔)

性能参数表 Slewing Drive Performance Parameters

Output Torque	Tilting Moment Torque	Holding Torque	Static Axial Rating	Static Radial Rating	Dynamic Axial Rating	Dynamic Radial Rating	Gear Ratio	Tracking Precision	Weight
输出转矩	倾覆力矩	保持力矩	轴向静载荷	径向静载荷	轴向动载荷	径向动载荷	减速比	精度等级	重量
8 kN.m	35.6 kN.m	34.5 kN.m	578 kN	215 kN	136 kN	115 kN	62 : 1	≤ 0.15°	54kg
5904 lbf.ft	26.3×10 ³ lbf.ft	25.5×10 ³ lbf.ft	129.9×10 ³ lbf	48.3×10 ³ lbf	30.6×10 ³ lbf	25.9×10 ³ lbf			

"A" VIEW AS INPUT IS ALLOWED
输入端允许在 "A" 向视图

SPECIAL DESIGN BASE ON CUSTOMER'S REQUIREMENT
可根据顾客的要求进行非标设计

NOTICE 注意

- Please be sure to remain under the curve. 选型时请确保实际载荷在曲线范围内。
- This drawing is just for your reference. 以上图纸仅供参考。
- This drawing is subject to change due to new design without prior notice. 本公司保留改进产品的权利而不再另行通知。
- Please contact the technical department for dimensions and performance parameters of the drives. 如果需要装置的外形尺寸和性能参数, 请与技术部门联系。

WEB12

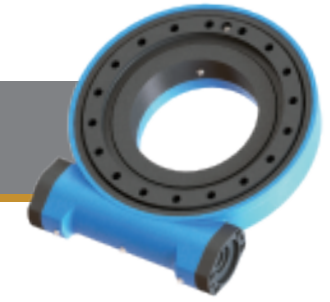

UNITS/单位:mm
1inch=25.4mm
Weight:70kg

FRONT VIEW
正视图

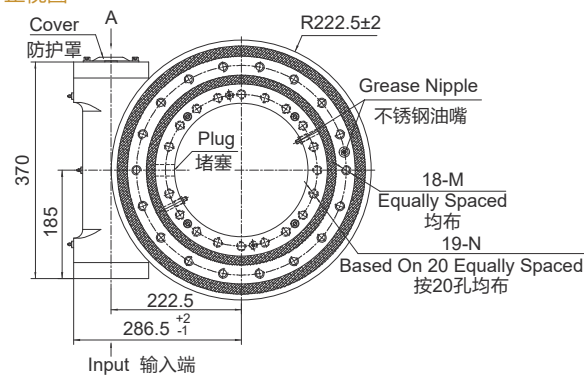

SIDE VIEW
侧视图

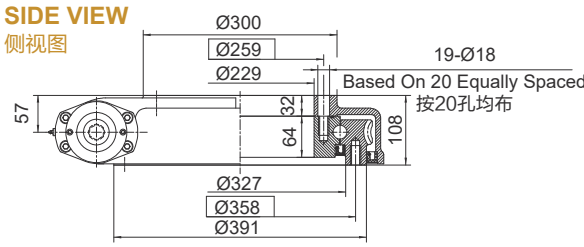

INPUT 输入端视图

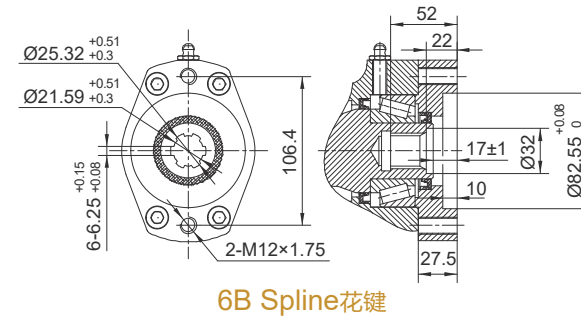
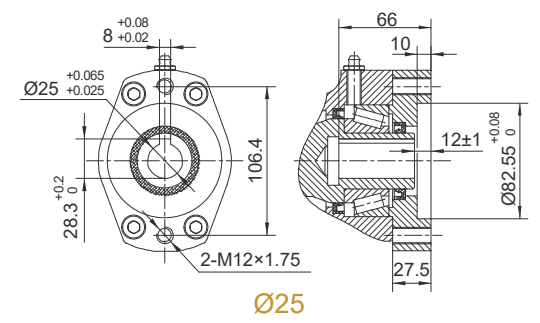

承载力矩图 MOMENT LOAD CHART

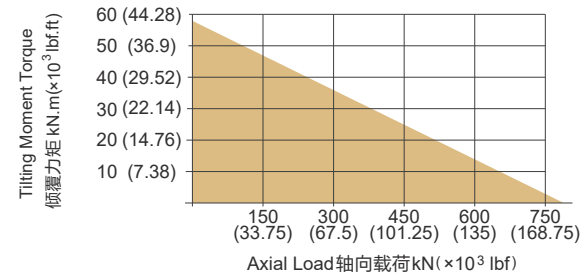

安装孔选项 Mounting Holes Option

Code 代码	M (Outer Ring 外圈)	N (Inner Ring 内圈)
—	M16×2 Tap (攻深)30	M16×2 Tap (攻深)30
T	M16×2 Tap (攻深)30	Ø18 Thru (通孔)
B	5/8"-11UNC-2B Tap (攻深)30	5/8"-11UNC-2B Tap (攻深)30
BT	5/8"-11UNC-2B Tap (攻深)30	Ø18 Thru (通孔)

性能参数表 Slewing Drive Performance Parameters

Output Torque	Tilting Moment Torque	Holding Torque	Static Axial Rating	Static Radial Rating	Dynamic Axial Rating	Dynamic Radial Rating	Gear Ratio	Tracking Precision	Weight
输出转矩	倾覆力矩	保持力矩	轴向静载荷	径向静载荷	轴向动载荷	径向动载荷	减速比	精度等级	重量
9.5 kN.m	57 kN.m	43 kN.m	760 kN	280 kN	190 kN	148 kN	79 : 1	≤ 0.15°	70kg
7011 lbf.ft	42.1×10 ³ lbf.ft	32×10 ³ lbf.ft	171.1×10 ³ lbf	62.9×10 ³ lbf	42.7×10 ³ lbf	33.3×10 ³ lbf			

"A" VIEW AS INPUT IS ALLOWED
输入端允许在 "A" 向视图

SPECIAL DESIGN BASE ON CUSTOMER'S REQUIREMENT
可根据顾客的要求进行非标设计

NOTICE 注意

- Please be sure to remain under the curve. 选型时请确保实际载荷在曲线范围内。
- This drawing is just for your reference. 以上图纸仅供参考。
- This drawing is subject to change due to new design without prior notice. 本公司保留改进产品的权利而不再另行通知。
- Please contact the technical department for dimensions and performance parameters of the drives. 如果需要装置的外形尺寸和性能参数, 请与技术部门联系。

WEB14

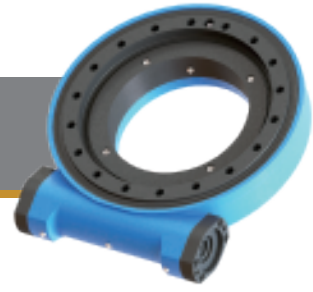

UNITS/单位:mm
1inch=25.4mm
Weight:76kg

FRONT VIEW
正视图

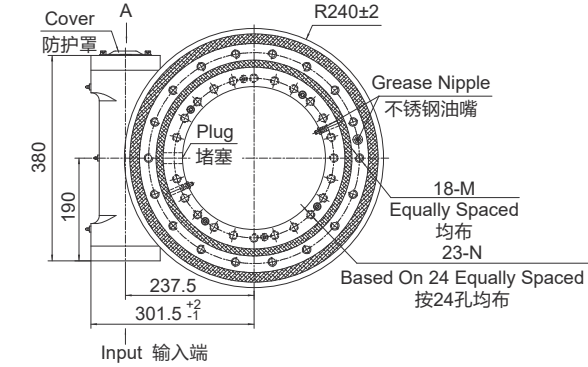

INPUT 输入端视图

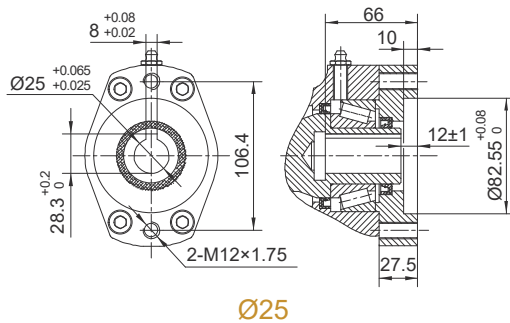

SIDE VIEW
侧视图

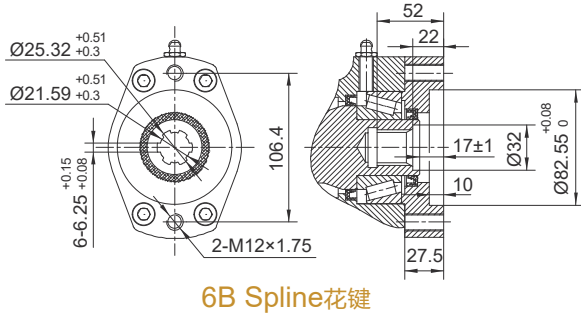
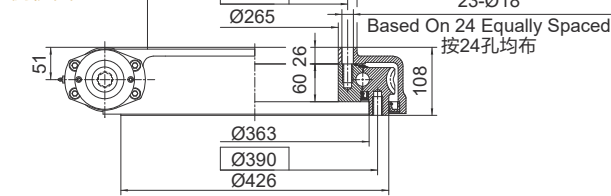

6B Spline花键

承载力矩图 MOMENT LOAD CHART

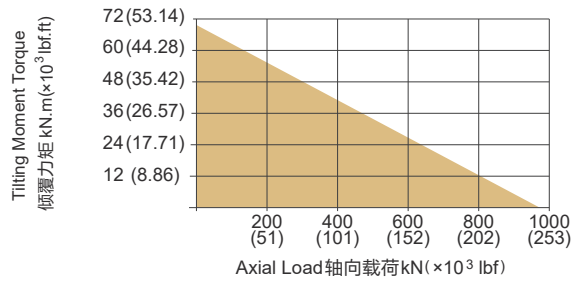

安装孔选项 Mounting Holes Option

Code 代码	M (Outer Ring 外圈)	N (Inner Ring 内圈)
—	M16×2 Tap (攻深)30	M16×2 Tap (攻深)30
T	M16×2 Tap (攻深)30	Ø18 Thru (通孔)
B	5/8"-11UNC-2B Tap (攻深)30	5/8"-11UNC-2B Tap (攻深)30
BT	5/8"-11UNC-2B Tap (攻深)30	Ø18 Thru (通孔)

性能参数表 Slewing Drive Performance Parameters

Output Torque	Tilting Moment Torque	Holding Torque	Static Axial Rating	Static Radial Rating	Dynamic Axial Rating	Dynamic Radial Rating	Gear Ratio	Tracking Precision	Weight
输出转矩	倾覆力矩	保持力矩	轴向静载荷	径向静载荷	轴向动载荷	径向动载荷	减速比	精度等级	重量
10.8 kN.m	71.2 kN.m	48 kN.m	960 kN	360 kN	230 kN	200 kN	86 : 1	≤ 0.13°	76kg
7970 lbf.ft	52.6×10³ lbf.ft	35×10³ lbf.ft	215.8×10³ lbf	80.9×10³ lbf	51.7×10³ lbf	44.9×10³ lbf			

"A" VIEW AS INPUT IS ALLOWED
输入端允许在“A”向视图

SPECIAL DESIGN BASE ON CUSTOMER'S REQUIREMENT
可根据顾客的要求进行非标设计

NOTICE
• Please be sure to remain under the curve. 选型时请确保实际载荷在曲线范围内。
• This drawing is just for your reference. 以上图纸仅供参考。
• This drawing is subject to change due to new design without prior notice. 本公司保留改进产品的权利而不再另行通知。
• Please contact the technical department for dimensions and performance parameters of the drives. 如果需要装置的外形尺寸和性能参数, 请与技术部门联系。

WEB14-2



UNITS/单位:mm
1inch=25.4mm
Weight:92kg

FRONT VIEW
正视图

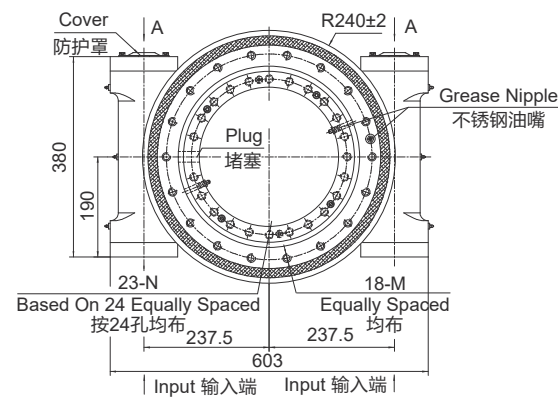

INPUT 输入端视图

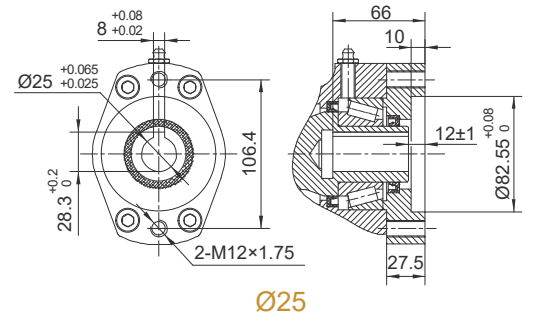

SIDE VIEW
侧视图

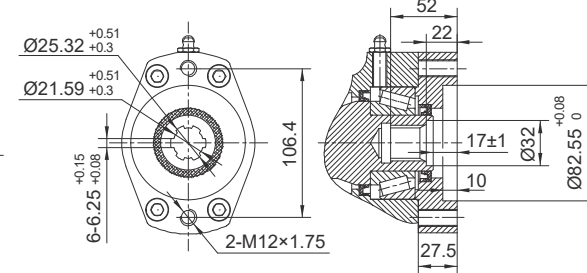
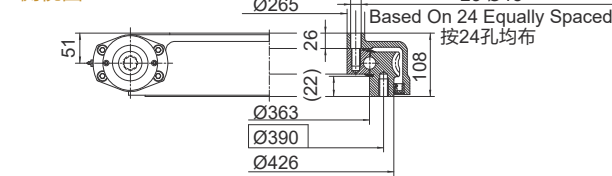

6B Spline花键

承载力矩图 MOMENT LOAD CHART

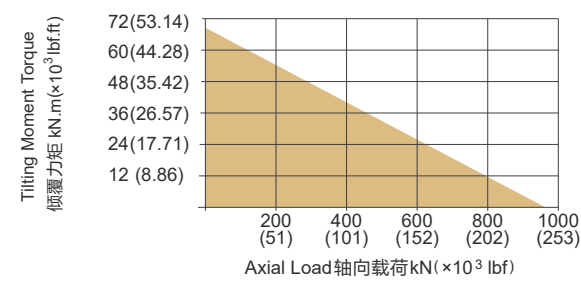

安装孔选项 Mounting Holes Option

Code 代码	M (Outer Ring 外圈)	N (Inner Ring 内圈)
—	M16×2 Tap (攻深)30	M16×2 Tap (攻深)30
T	M16×2 Tap (攻深)30	Ø18 Thru (通孔)
B	5/8"-11UNC-2B Tap (攻深)30	5/8"-11UNC-2B Tap (攻深)30
BT	5/8"-11UNC-2B Tap (攻深)30	Ø18 Thru (通孔)

性能参数表 Slewing Drive Performance Parameters

Output Torque	Tilting Moment Torque	Holding Torque	Static Axial Rating	Static Radial Rating	Dynamic Axial Rating	Dynamic Radial Rating	Gear Ratio	Tracking Precision	Weight
输出转矩	倾覆力矩	保持力矩	轴向静载荷	径向静载荷	轴向动载荷	径向动载荷	减速比	精度等级	重量
16.2 kN.m	71.2 kN.m	82 kN.m	960 kN	360 kN	230 kN	200 kN	86 : 1	≤ 0.15°	92kg
11956 lbf.ft	52.6×10³ lbf.ft	60.5×10³ lbf.ft	215.8×10³ lbf	80.9×10³ lbf	51.7×10³ lbf	44.9×10³ lbf			

"A" VIEW AS INPUT IS ALLOWED
输入端允许在“A”向视图

SPECIAL DESIGN BASE ON CUSTOMER'S REQUIREMENT
可根据顾客的要求进行非标设计

NOTICE
• Please be sure to remain under the curve. 选型时请确保实际载荷在曲线范围内。
• This drawing is just for your reference. 以上图纸仅供参考。
• This drawing is subject to change due to new design without prior notice. 本公司保留改进产品的权利而不再另行通知。
• Please contact the technical department for dimensions and performance parameters of the drives. 如果需要装置的外形尺寸和性能参数, 请与技术部门联系。

WEB15

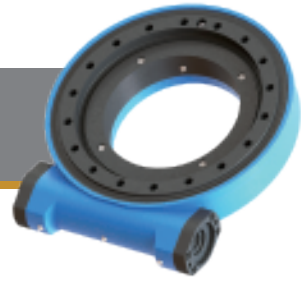

UNITS/单位:mm
1inch=25.4mm
Weight:68kg

FRONT VIEW
正视图

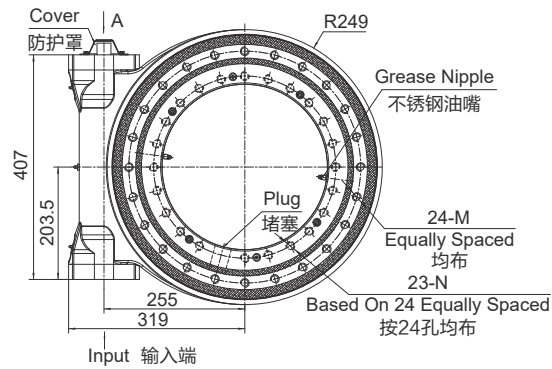

INPUT 输入端视图

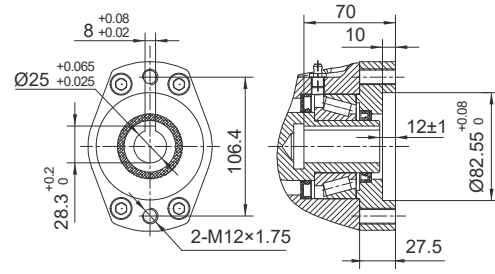

Ø25

SIDE VIEW
侧视图

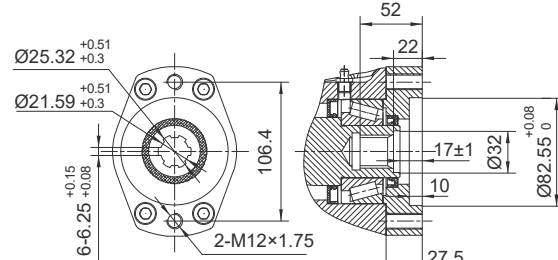
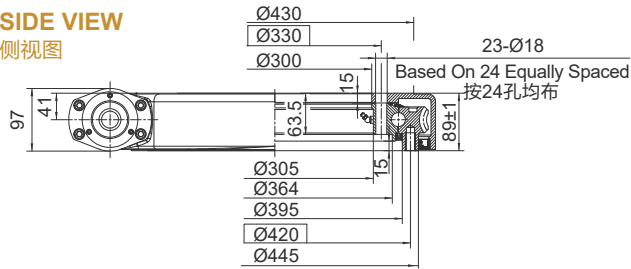

6B Spline花键

承载力矩图 MOMENT LOAD CHART

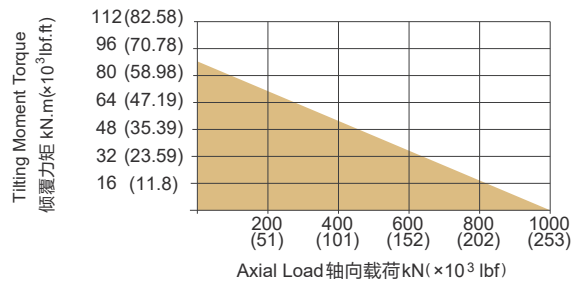

安装孔选项 Mounting Holes Option

Code 代码	M (Outer Ring 外圈)	N (Inner Ring 内圈)
—	M16x2 Tap (攻深)28	M16x2 Tap (攻深)28
T	M16x2 Tap (攻深)28	Ø17 Thru (通孔)
B	5/8"-11UNC-2B Tap (攻深)28	5/8"-11UNC-2B Tap (攻深)28
BT	5/8"-11UNC-2B Tap (攻深)28	Ø17Thru (通孔)

性能参数表 Slewing Drive Performance Parameters

Output Torque	Tilting Moment Torque	Holding Torque	Static Axial Rating	Static Radial Rating	Dynamic Axial Rating	Dynamic Radial Rating	Gear Ratio	Tracking Precision	Weight
输出转矩	倾覆力矩	保持力矩	轴向静载荷	径向静载荷	轴向动载荷	径向动载荷	减速比	精度等级	重量
12 kN.m	90 kN.m	50 kN.m	1000 kN	400 kN	240 kN	220 kN	92 : 1	≤ 0.1°	68kg
8856 lbf.ft	66x10 ³ lbf.ft	37x10 ³ lbf.ft	224.8x10 ³ lbf	89.9x10 ³ lbf	54x10 ³ lbf	49.5x10 ³ lbf			

"A" VIEW AS INPUT IS ALLOWED
输入端允许在“A”向视图

SPECIAL DESIGN BASE ON CUSTOMER'S REQUIREMENT
可根据顾客的要求进行非标设计

- NOTICE 注意**
- Please be sure to remain under the curve. 选型时请确保实际载荷在曲线范围内。
 - This drawing is just for your reference. 以上图纸仅供参考。
 - This drawing is subject to change due to new design without prior notice. 本公司保留改进产品的权利而不再另行通知。
 - Please contact the technical department for dimensions and performance parameters of the drives. 如果需要装置的外形尺寸和性能参数, 请与技术部门联系。

WEB17

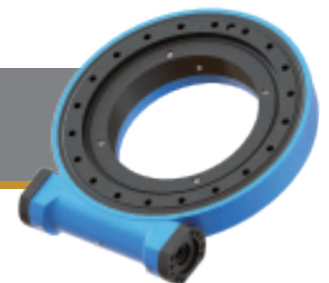

UNITS/单位:mm
1inch=25.4mm
Weight:101kg

FRONT VIEW
正视图

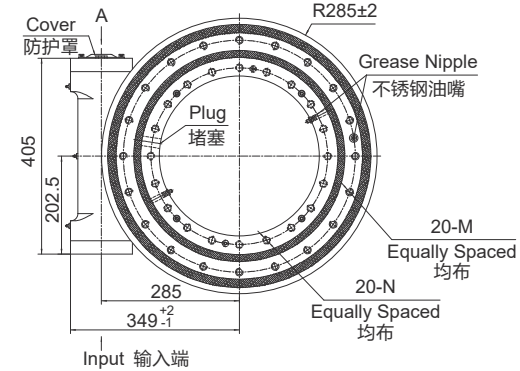

INPUT 输入端视图

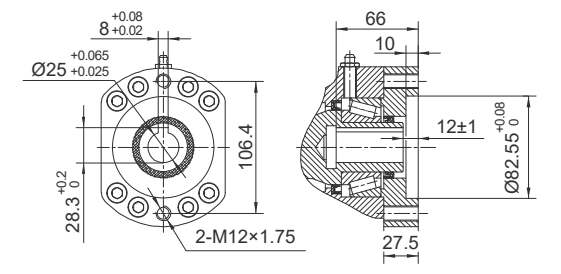

Ø25

SIDE VIEW
侧视图

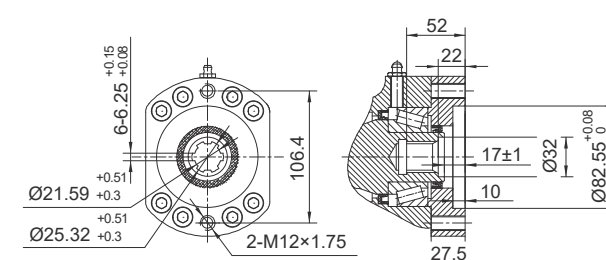
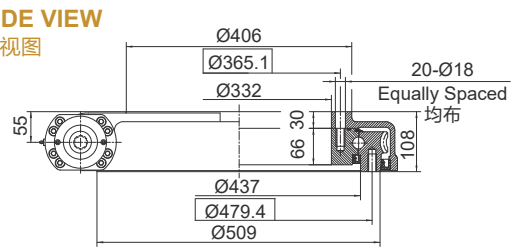

6B Spline花键

承载力矩图 MOMENT LOAD CHART

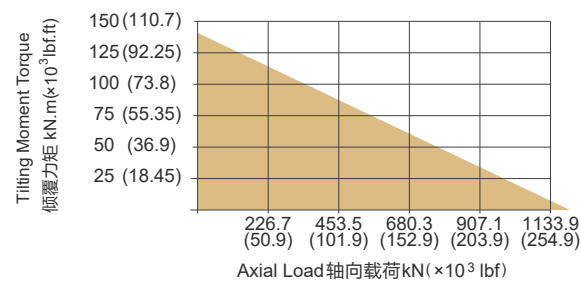

安装孔选项 Mounting Holes Option

Code 代码	M (Outer Ring 外圈)	N (Inner Ring 内圈)
—	M16x2 Tap (攻深)32	M16x2 Tap (攻深)32
T	M16x2 Tap (攻深)32	Ø18 Thru (通孔)
B	5/8"-11UNC-2B Tap (攻深)32	5/8"-11UNC-2B Tap (攻深)32
BT	5/8"-11UNC-2B Tap (攻深)32	Ø18 Thru (通孔)

性能参数表 Slewing Drive Performance Parameters

Output Torque	Tilting Moment Torque	Holding Torque	Static Axial Rating	Static Radial Rating	Dynamic Axial Rating	Dynamic Radial Rating	Gear Ratio	Tracking Precision	Weight
输出转矩	倾覆力矩	保持力矩	轴向静载荷	径向静载荷	轴向动载荷	径向动载荷	减速比	精度等级	重量
12.96 kN.m	142.4 kN.m	72.3 kN.m	1166 kN	435 kN	280 kN	231 kN	104 : 1	≤ 0.1°	101kg
9564 lbf.ft	105x10 ³ lbf.ft	53.4x10 ³ lbf.ft	262x10 ³ lbf	97.8x10 ³ lbf	62.9x10 ³ lbf	51.9x10 ³ lbf			

"A" VIEW AS INPUT IS ALLOWED
输入端允许在“A”向视图

SPECIAL DESIGN BASE ON CUSTOMER'S REQUIREMENT
可根据顾客的要求进行非标设计

- NOTICE 注意**
- Please be sure to remain under the curve. 选型时请确保实际载荷在曲线范围内。
 - This drawing is just for your reference. 以上图纸仅供参考。
 - This drawing is subject to change due to new design without prior notice. 本公司保留改进产品的权利而不再另行通知。
 - Please contact the technical department for dimensions and performance parameters of the drives. 如果需要装置的外形尺寸和性能参数, 请与技术部门联系。

WEB17-2



UNITS/单位:mm
1inch=25.4mm
Weight:126kg

FRONT VIEW
正视图

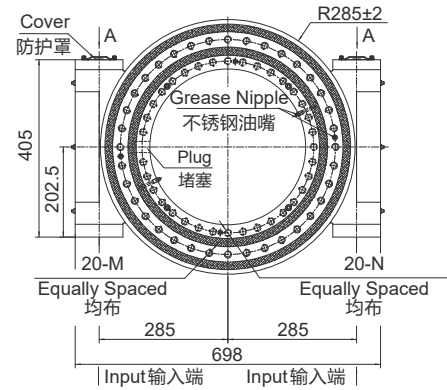

INPUT 输入端视图

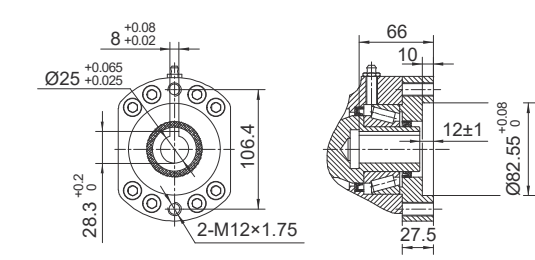

Ø25

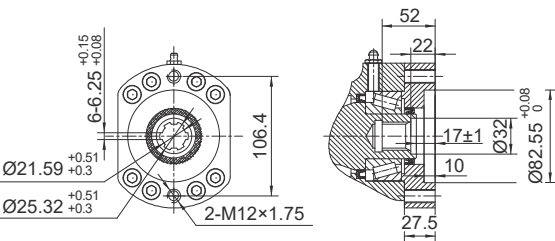

6B Spline花键

SIDE VIEW
侧视图

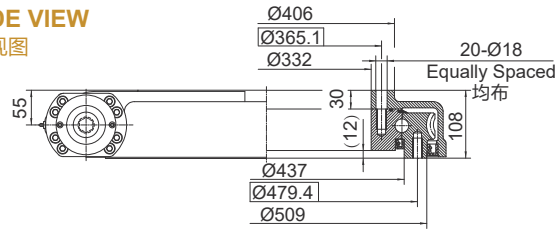

承载力矩图 MOMENT LOAD CHART

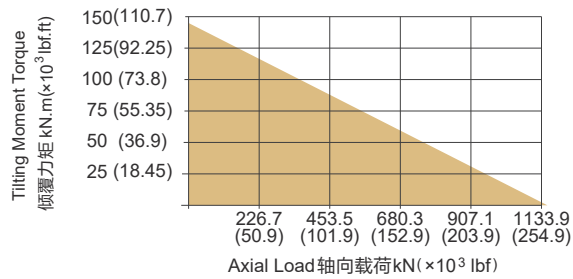

安装孔选项 Mounting Holes Option

Code 代码	M (Outer Ring 外圈)	N (Inner Ring 内圈)
—	M16×2 Tap (攻深)32	M16×2 Tap (攻深)32
T	M16×2 Tap (攻深)32	Ø18 Thru (通孔)
B	5/8"-11UNC-2B Tap (攻深)32	5/8"-11UNC-2B Tap (攻深)32
BT	5/8"-11UNC-2B Tap (攻深)32	Ø18 Thru (通孔)

性能参数表 Slewing Drive Performance Parameters

Output Torque	Tilting Moment Torque	Holding Torque	Static Axial Rating	Static Radial Rating	Dynamic Axial Rating	Dynamic Radial Rating	Gear Ratio	Tracking Precision	Weight
输出转矩	倾覆力矩	保持力矩	轴向静载荷	径向静载荷	轴向动载荷	径向动载荷	减速比	精度等级	重量
19.44 kN.m	142.4 kN.m	94 kN.m	1166 kN	435 kN	280 kN	231 kN	104 : 1	≤ 0.15°	126kg
14347 lbf.ft	105.1×10³ lbf.ft	53.4×10³ lbf.ft	262×10³ lbf	97.8×10³ lbf	62.9×10³ lbf	51.9×10³ lbf			

"A" VIEW AS INPUT IS ALLOWED
输入端允许在 "A" 向视图

SPECIAL DESIGN BASE ON CUSTOMER'S REQUIREMENT
可根据顾客的要求进行非标设计

- NOTICE 注意**
- Please be sure to remain under the curve. 选型时请确保实际载荷在曲线范围内。
 - This drawing is just for your reference. 以上图纸仅供参考。
 - This drawing is subject to change due to new design without prior notice. 本公司保留改进产品的权利而不再另行通知。
 - Please contact the technical department for dimensions and performance parameters of the drives. 如果需要装置的外形尺寸和性能参数, 请与技术部门联系。

WEB19B

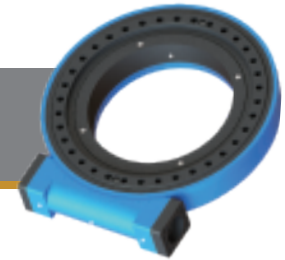

UNITS/单位:mm
1inch=25.4mm
Weight:128kg

FRONT VIEW
正视图

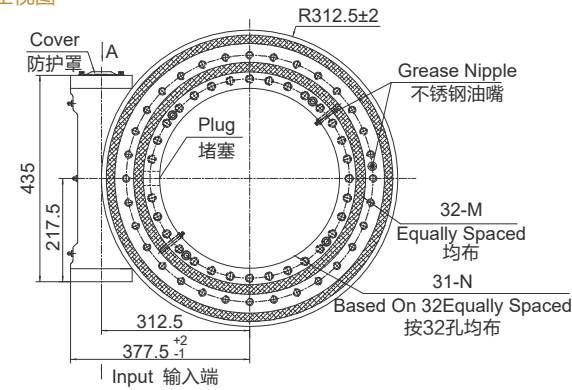

INPUT 输入端视图

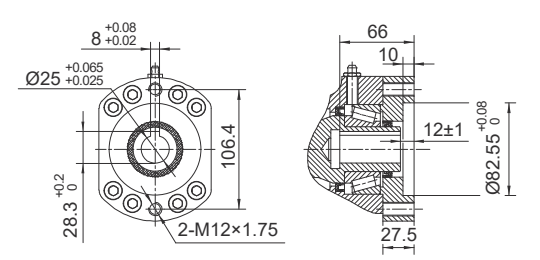

Ø25

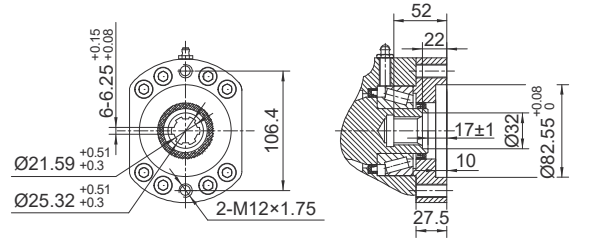

6B Spline花键

SIDE VIEW
侧视图

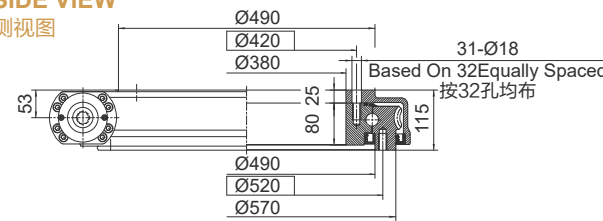

承载力矩图 MOMENT LOAD CHART

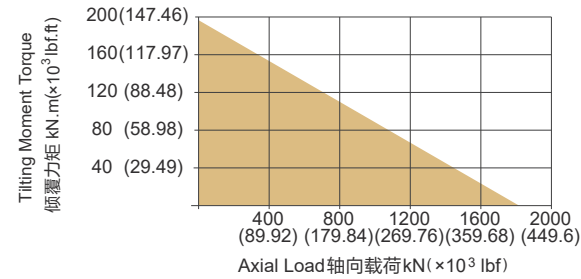

安装孔选项 Mounting Holes Option

Code 代码	M (Outer Ring 外圈)	N (Inner Ring 内圈)
—	M16×2 Tap (攻深)32	M16×2 Tap (攻深)32
T	M16×2 Tap (攻深)32	Ø18 Thru (通孔)
B	5/8"-11UNC-2B Tap (攻深)32	5/8"-11UNC-2B Tap (攻深)32
BT	5/8"-11UNC-2B Tap (攻深)32	Ø18 Thru (通孔)

性能参数表 Slewing Drive Performance Parameters

Output Torque	Tilting Moment Torque	Holding Torque	Static Axial Rating	Static Radial Rating	Dynamic Axial Rating	Dynamic Radial Rating	Gear Ratio	Tracking Precision	Weight
输出转矩	倾覆力矩	保持力矩	轴向静载荷	径向静载荷	轴向动载荷	径向动载荷	减速比	精度等级	重量
18.5 kN.m	196 kN.m	80.1 kN.m	1800 kN	675 kN	290 kN	250 kN	94 : 1	≤ 0.1°	128kg
13653 lbf.ft	144.6×10³ lbf.ft	59.1×10³ lbf.ft	404.6×10³ lbf	151.7×10³ lbf	65.2×10³ lbf	56.2×10³ lbf			

"A" VIEW AS INPUT IS ALLOWED
输入端允许在 "A" 向视图

SPECIAL DESIGN BASE ON CUSTOMER'S REQUIREMENT
可根据顾客的要求进行非标设计

- NOTICE 注意**
- Please be sure to remain under the curve. 选型时请确保实际载荷在曲线范围内。
 - This drawing is just for your reference. 以上图纸仅供参考。
 - This drawing is subject to change due to new design without prior notice. 本公司保留改进产品的权利而不再另行通知。
 - Please contact the technical department for dimensions and performance parameters of the drives. 如果需要装置的外形尺寸和性能参数, 请与技术部门联系。

WEB21

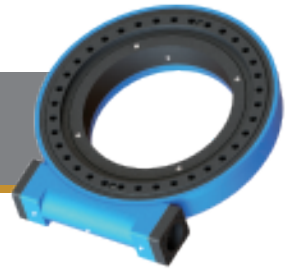

UNITS/单位:mm
1inch=25.4mm
Weight:182kg

FRONT VIEW
正视图

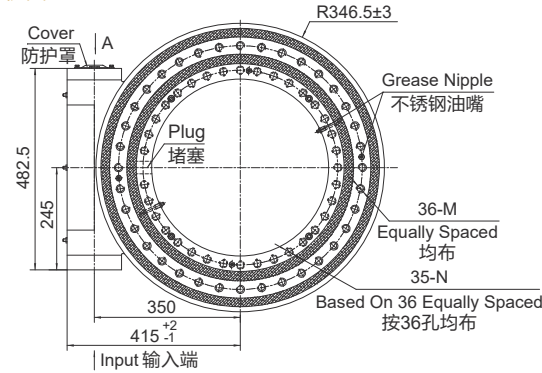

INPUT 输入端视图

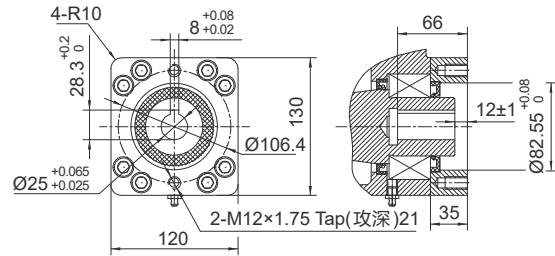

SIDE VIEW
侧视图

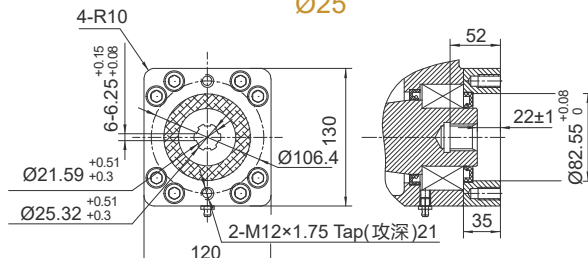
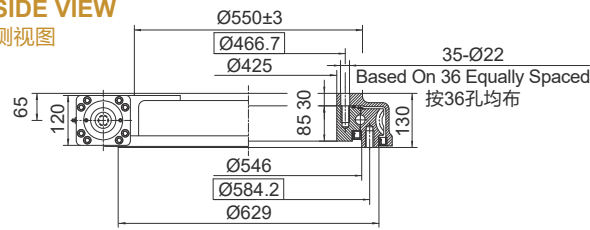

6B Spline花键

承载力矩图 MOMENT LOAD CHART

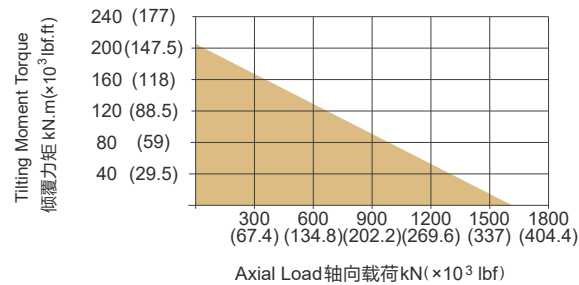

安装孔选项 Mounting Holes Option

Code 代码	M (Outer Ring 外圈)	N (Inner Ring 内圈)
—	M20×2.5 Tap (攻深)40	M20×2.5 Tap (攻深)40
T	M20×2.5 Tap (攻深)40	Ø22 Thru (通孔)
B	3/4"-10UNC-2B Tap (攻深)40	3/4"-10UNC-2B Tap (攻深)40
BT	3/4"-10UNC-2B Tap (攻深)40	Ø22 Thru (通孔)

性能参数表 Slewing Drive Performance Parameters

Output Torque	Tilting Moment Torque	Holding Torque	Static Axial Rating	Static Radial Rating	Dynamic Axial Rating	Dynamic Radial Rating	Gear Ratio	Tracking Precision	Weight
输出转矩	倾覆力矩	保持力矩	轴向静载荷	径向静载荷	轴向动载荷	径向动载荷	减速比	精度等级	重量
28.7 kN.m	203 kN.m	105.8 kN.m	1598 kN	640 kN	385 kN	335 kN	90 : 1	≤ 0.1°	182kg
21180 lbf.ft	105×10 ³ lbf.ft	78.1×10 ³ lbf.ft	359×10 ³ lbf	144×10 ³ lbf	87×10 ³ lbf	75×10 ³ lbf			

"A" VIEW AS INPUT IS ALLOWED
输入端允许在“A”向视图

SPECIAL DESIGN BASE ON CUSTOMER'S REQUIREMENT
可根据顾客的要求进行非标设计

- NOTICE**
- Please be sure to remain under the curve. 选型时请确保实际载荷在曲线范围内。
 - This drawing is just for your reference. 以上图纸仅供参考。
 - This drawing is subject to change due to new design without prior notice. 本公司保留改进产品的权利而不再另行通知。
 - Please contact the technical department for dimensions and performance parameters of the drives. 如果需要装置的外形尺寸和性能参数, 请与技术部门联系。

WEB21-2



UNITS/单位:mm
1inch=25.4mm
Weight:213kg

FRONT VIEW
正视图

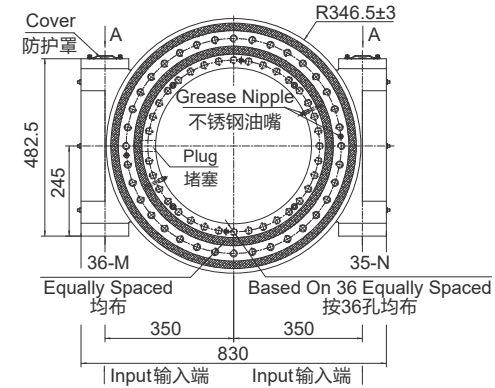

INPUT 输入端视图

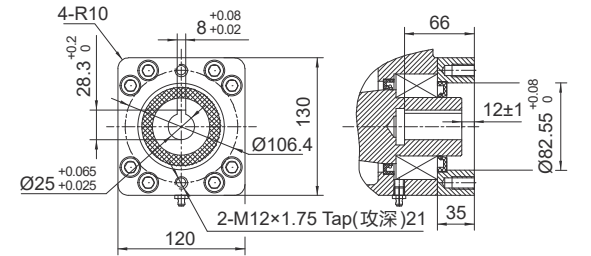

SIDE VIEW
侧视图

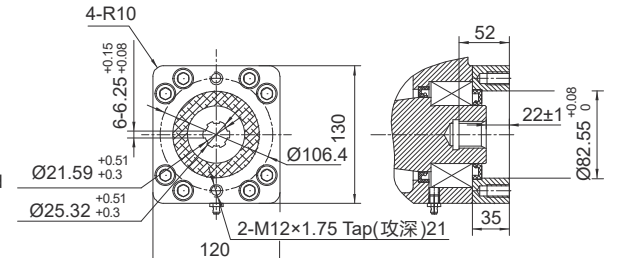
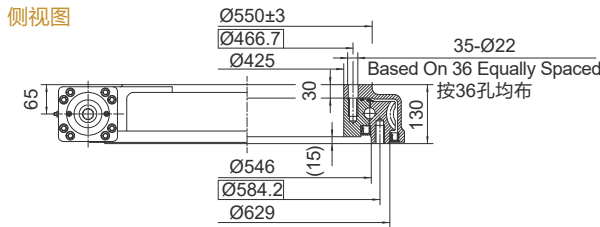

6B Spline花键

承载力矩图 MOMENT LOAD CHART

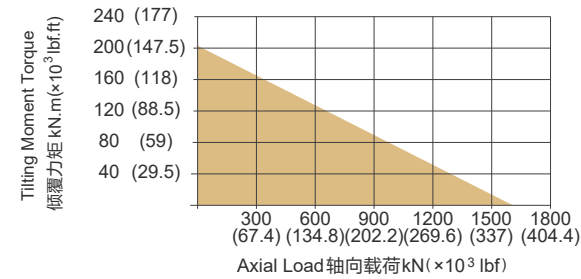

安装孔选项 Mounting Holes Option

Code 代码	M (Outer Ring 外圈)	N (Inner Ring 内圈)
—	M20×2.5 Tap (攻深)40	M20×2.5 Tap (攻深)40
T	M20×2.5 Tap (攻深)40	Ø22 Thru (通孔)
B	3/4"-10UNC-2B Tap (攻深)40	3/4"-10UNC-2B Tap (攻深)40
BT	3/4"-10UNC-2B Tap (攻深)40	Ø22 Thru (通孔)

性能参数表 Slewing Drive Performance Parameters

Output Torque	Tilting Moment Torque	Holding Torque	Static Axial Rating	Static Radial Rating	Dynamic Axial Rating	Dynamic Radial Rating	Gear Ratio	Tracking Precision	Weight
输出转矩	倾覆力矩	保持力矩	轴向静载荷	径向静载荷	轴向动载荷	径向动载荷	减速比	精度等级	重量
48 kN.m	203 kN.m	179.9 kN.m	1598 kN	640 kN	385 kN	335 kN	90 : 1	≤ 0.13°	213kg
35400 lbf.ft	105×10 ³ lbf.ft	133×10 ³ lbf.ft	359×10 ³ lbf	144×10 ³ lbf	87×10 ³ lbf	75×10 ³ lbf			

"A" VIEW AS INPUT IS ALLOWED
输入端允许在“A”向视图

SPECIAL DESIGN BASE ON CUSTOMER'S REQUIREMENT
可根据顾客的要求进行非标设计

- NOTICE**
- Please be sure to remain under the curve. 选型时请确保实际载荷在曲线范围内。
 - This drawing is just for your reference. 以上图纸仅供参考。
 - This drawing is subject to change due to new design without prior notice. 本公司保留改进产品的权利而不再另行通知。
 - Please contact the technical department for dimensions and performance parameters of the drives. 如果需要装置的外形尺寸和性能参数, 请与技术部门联系。

WEB25



UNITS/单位:mm
1inch=25.4mm
Weight:212kg

FRONT VIEW 正视图

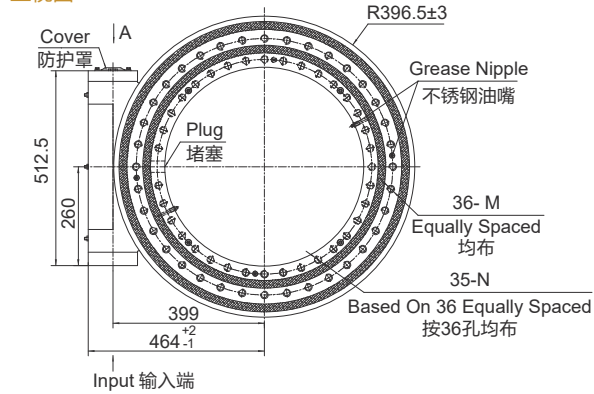

INPUT 输入端视图

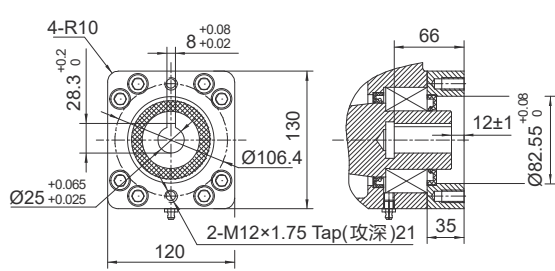

Ø25

SIDE VIEW 侧视图

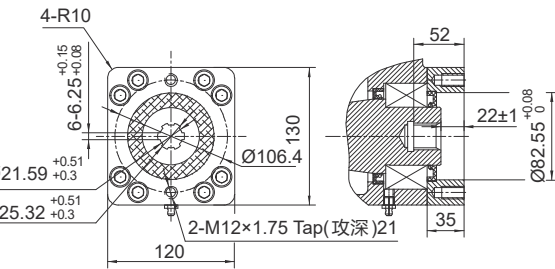
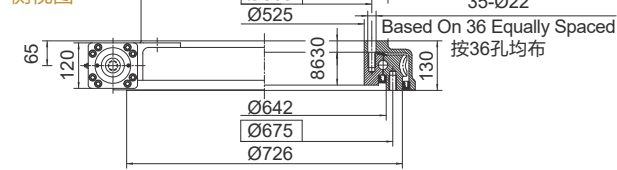

6B Spline花键

承载力矩图 MOMENT LOAD CHART

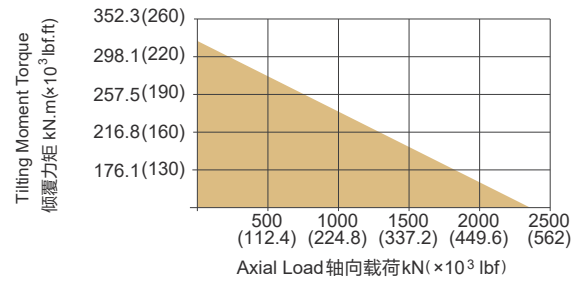

安装孔选项 Mounting Holes Option

Code 代码	M (Outer Ring 外圈)	N (Inner Ring 内圈)
—	M20×2.5 Tap (攻深)40	M20×2.5 Tap (攻深)40
T	M20×2.5 Tap (攻深)40	Ø22 Thru (通孔)
B	3/4"-10UNC-2B Tap (攻深)40	3/4"-10UNC-2B Tap (攻深)40
BT	3/4"-10UNC-2B Tap (攻深)40	Ø22Thru (通孔)

性能参数表 Slewing Drive Performance Parameters

Output Torque	Tilting Moment Torque	Holding Torque	Static Axial Rating	Static Radial Rating	Dynamic Axial Rating	Dynamic Radial Rating	Gear Ratio	Tracking Precision	Weight
输出转矩	倾覆力矩	保持力矩	轴向静载荷	径向静载荷	轴向动载荷	径向动载荷	减速比	精度等级	重量
34.2 kN.m	310 kN.m	158.3 kN.m	2360 kN	945 kN	590 kN	470 kN	104 : 1	≤ 0.1°	212kg
25240 lbf.ft	229×10 ³ lbf.ft	117×10 ³ lbf.ft	531×10 ³ lbf	212×10 ³ lbf	133×10 ³ lbf	106×10 ³ lbf			

"A" VIEW AS INPUT IS ALLOWED
输入端允许在 "A" 向视图

SPECIAL DESIGN BASE ON CUSTOMER'S REQUIREMENT
可根据顾客的要求进行非标设计

- NOTICE 注意**
- Please be sure to remain under the curve. 选型时请确保实际载荷在曲线范围内。
 - This drawing is just for your reference. 以上图纸仅供参考。
 - This drawing is subject to change due to new design without prior notice. 本公司保留改进产品的权利而不再另行通知。
 - Please contact the technical department for dimensions and performance parameters of the drives. 如果需要装置的外形尺寸和性能参数, 请与技术部门联系。

WEB25-2



UNITS/单位:mm
1inch=25.4mm
Weight:280kg

FRONT VIEW 正视图

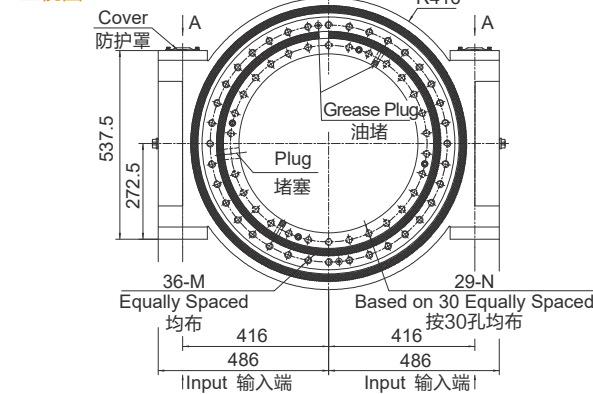

INPUT 输入端视图

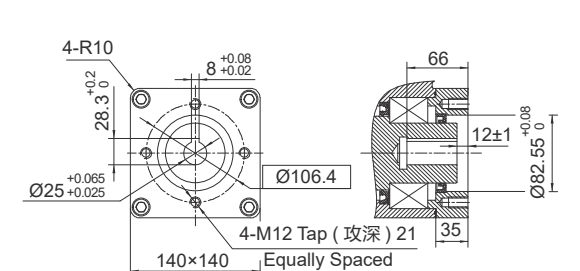

Ø25

SIDE VIEW 侧视图

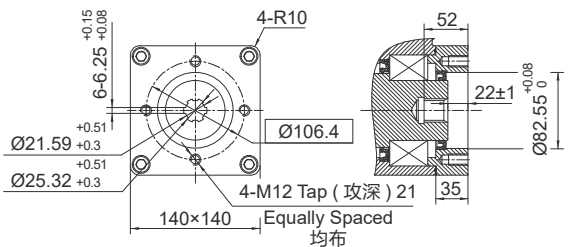
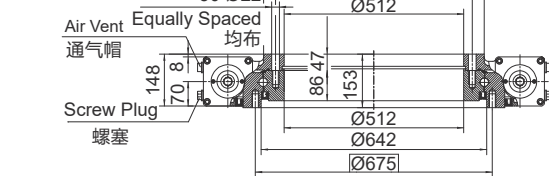

6B Spline花键

承载力矩图 MOMENT LOAD CHART

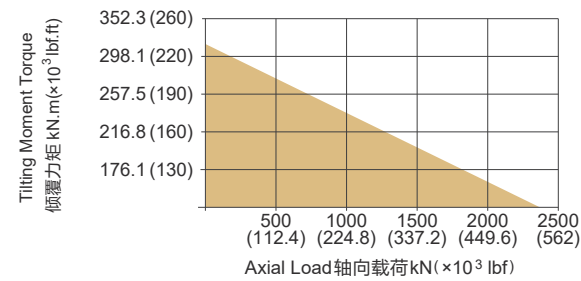

安装孔选项 Mounting Holes Option

Code 代码	M (Outer Ring 外圈)	N (Inner Ring 内圈)
—	M20×2.5 Tap (攻深)40	M20×2.5 Tap (攻深)40
T	M20×2.5 Tap (攻深)40	Ø22 Thru (通孔)
B	3/4"-10UNC-2B Tap (攻深)40	3/4"-10UNC-2B Tap (攻深)40
BT	3/4"-10UNC-2B Tap (攻深)40	Ø22 Thru (通孔)

性能参数表 Slewing Drive Performance Parameters

Output Torque	Tilting Moment Torque	Holding Torque	Static Axial Rating	Static Radial Rating	Dynamic Axial Rating	Dynamic Radial Rating	Gear Ratio	Tracking Precision	Weight
输出转矩	倾覆力矩	保持力矩	轴向静载荷	径向静载荷	轴向动载荷	径向动载荷	减速比	精度等级	重量
58 kN.m	310 kN.m	247 kN.m	2360 kN	945 kN	590 kN	470 kN	108 : 1	≤ 0.12°	280kg
42800 lbf.ft	229×10 ³ lbf.ft	182.3×10 ³ lbf.ft	531×10 ³ lbf	212×10 ³ lbf	133×10 ³ lbf	106×10 ³ lbf			

"A" VIEW AS INPUT IS ALLOWED
输入端允许在 "A" 向视图

SPECIAL DESIGN BASE ON CUSTOMER'S REQUIREMENT
可根据顾客的要求进行非标设计

- NOTICE 注意**
- Please be sure to remain under the curve. 选型时请确保实际载荷在曲线范围内。
 - This drawing is just for your reference. 以上图纸仅供参考。
 - This drawing is subject to change due to new design without prior notice. 本公司保留改进产品的权利而不再另行通知。
 - Please contact the technical department for dimensions and performance parameters of the drives. 如果需要装置的外形尺寸和性能参数, 请与技术部门联系。

SE3C-PE3C

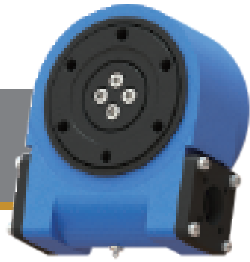

UNITS/单位:mm
1inch=25.4mm

Weight:12kg

FRONT VIEW
正视图

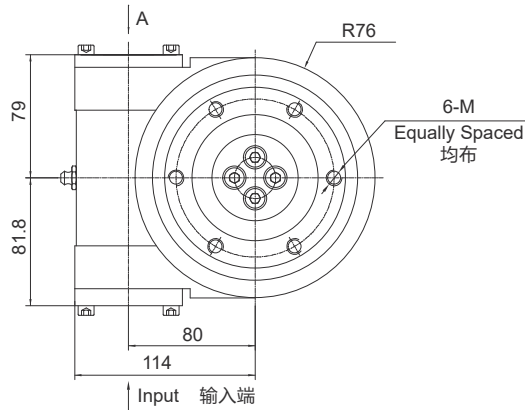

INPUT 输入端视图

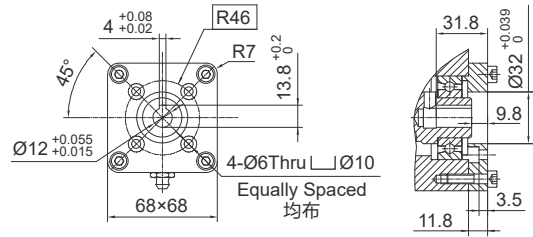

Ø12

承载力矩图 MOMENT LOAD CHART

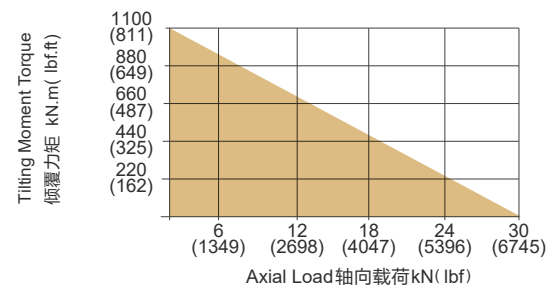

安装孔选项 Mounting Holes Option

Code 代码	M (Outer Ring 外圈)	N (Inner Ring 内圈)
—	M10×1.5 Tap (攻深)22	M10×1.5 Tap (攻深)17
B	3/8"-16UNC-2B Tap (攻深)22	3/8"-16UNC-2B Tap (攻深)17

SIDE VIEW
侧视图

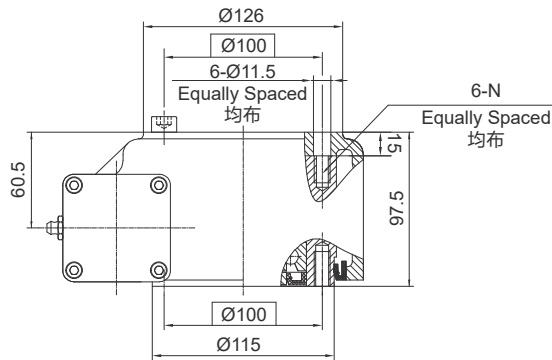

性能参数表 Slewing Drive Performance Parameters

Model	Output Torque	Tilting Moment Torque	Holding Torque	Static Axial Rating	Static Radial Rating	Dynamic Axial Rating	Dynamic Radial Rating	Gear Ratio	Tracking Precision	Weight
类型	输出转矩	倾覆力矩	保持力矩	轴向静载荷	径向静载荷	轴向动载荷	径向动载荷	减速比	精度等级	重量
SE3C	400 N.m	1100 N.m	2000 N.m	30 kN	16.6 kN	9.6 kN	8.4 kN	62 : 1	≤ 0.2°	12 kg
	295 lbf.ft	811 lbf.ft	1475 lbf.ft	6744 lbf	3732 lbf	2158 lbf	1888 lbf			
PE3C	400 N.m	1100 N.m	2000 N.m	30 kN	16.6 kN	9.6 kN	8.4 kN	62 : 1	≤ 0.15°	12 kg
	295 lbf.ft	811 lbf.ft	1475 lbf.ft	6744 lbf	3732 lbf	2158 lbf	1888 lbf			

"A" VIEW AS INPUT IS ALLOWED
输入端允许在 "A" 向视图

SPECIAL DESIGN BASE ON CUSTOMER'S REQUIREMENT
可根据顾客的要求进行非标设计

NOTICE
Please be sure to remain under the curve. 选型时请确保实际载荷在曲线范围内。
This drawing is just for your reference. 以上图纸仅供参考。
This drawing is subject to change due to new design without prior notice. 本公司保留改进产品的权利而不再另行通知。
Please contact the technical department for dimensions and performance parameters of the drives. 如果需要装置的外形尺寸和性能参数, 请与技术部门联系。

SE5C-PE5C

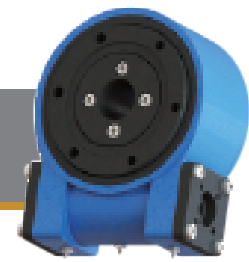

UNITS/单位:mm
1inch=25.4mm

Weight:16kg

FRONT VIEW
正视图

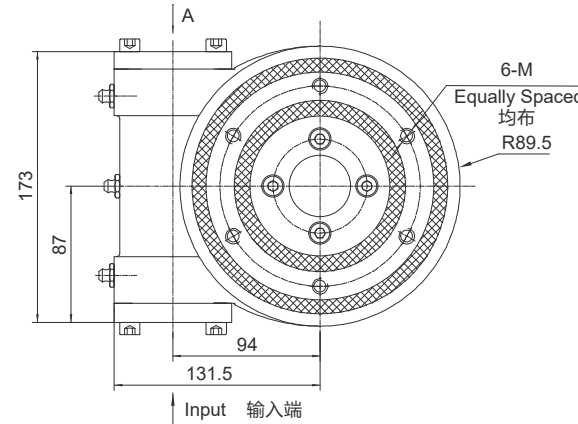

INPUT 输入端视图

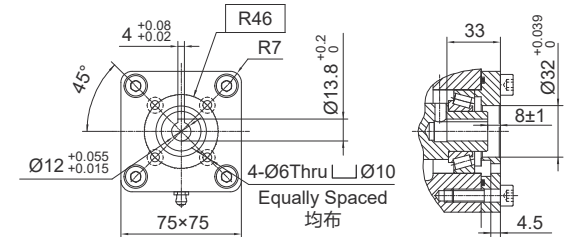

Ø12

承载力矩图 MOMENT LOAD CHART

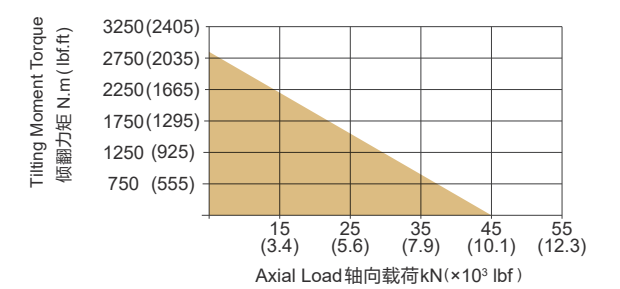

安装孔选项 Mounting Holes Option

Code 代码	M (Outer Ring 外圈)	N (Inner Ring 内圈)
—	M10×1.5 Tap (攻深)20	M10×1.5 Tap (攻深)18
B	3/8"-16UNC-2B Tap (攻深)20	3/8"-16UNC-2B Tap (攻深)18

SIDE VIEW
侧视图

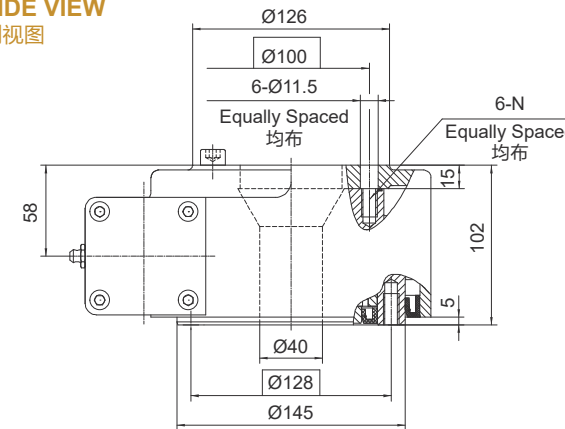

性能参数表 Slewing Drive Performance Parameters

Model	Output Torque	Tilting Moment Torque	Holding Torque	Static Axial Rating	Static Radial Rating	Dynamic Axial Rating	Dynamic Radial Rating	Gear Ratio	Tracking Precision	Weight
类型	输出转矩	倾覆力矩	保持力矩	轴向静载荷	径向静载荷	轴向动载荷	径向动载荷	减速比	精度等级	重量
SE5C	600 N.m	2800 N.m	5000 N.m	45 kN	22 kN	14.4 kN	11.1 kN	62 : 1	≤ 0.2°	16 kg
	422.5 lbf.ft	2066.4 lbf.ft	3690 lbf.ft	10116 lbf	4945.6 lbf	3237.1 lbf	2495.3 lbf			
PE5C	600 N.m	2800 N.m	5000 N.m	45 kN	22 kN	14.4 kN	11.1 kN	62 : 1	≤ 0.12°	16 kg
	422.5 lbf.ft	2066.4 lbf.ft	3690 lbf.ft	10116 lbf	4945.6 lbf	3237.1 lbf	2495.3 lbf			

"A" VIEW AS INPUT IS ALLOWED
输入端允许在 "A" 向视图

SPECIAL DESIGN BASE ON CUSTOMER'S REQUIREMENT
可根据顾客的要求进行非标设计

NOTICE
Please be sure to remain under the curve. 选型时请确保实际载荷在曲线范围内。
This drawing is just for your reference. 以上图纸仅供参考。
This drawing is subject to change due to new design without prior notice. 本公司保留改进产品的权利而不再另行通知。
Please contact the technical department for dimensions and performance parameters of the drives. 如果需要装置的外形尺寸和性能参数, 请与技术部门联系。

SE7A-PE7A

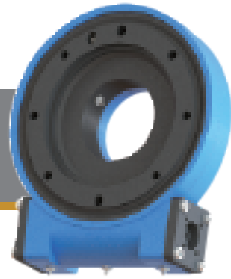

UNITS/单位:mm
1inch=25.4mm
Weight:25kg

FRONT VIEW
正视图

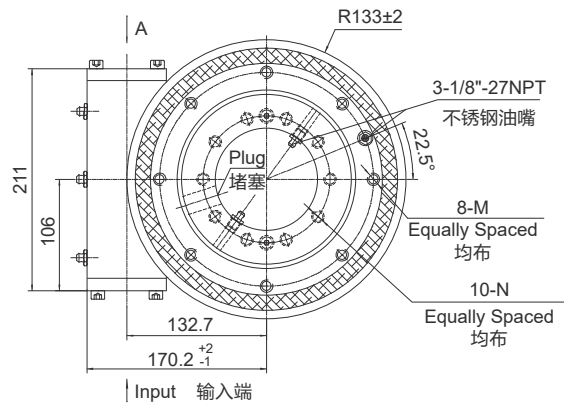

SIDE VIEW
侧视图

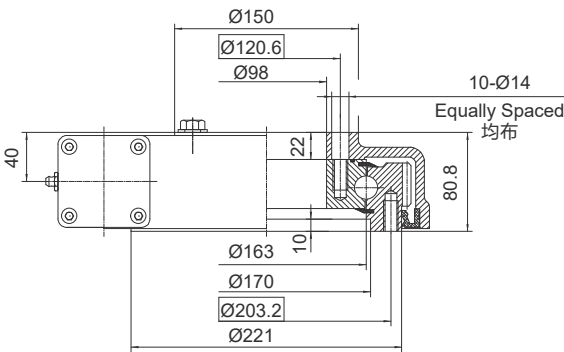

INPUT 输入端视图

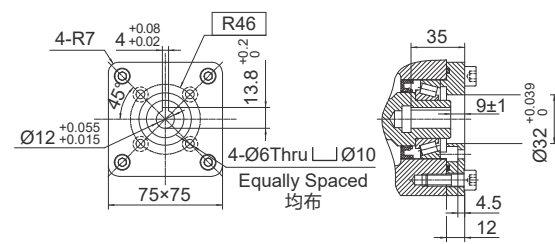

Ø12

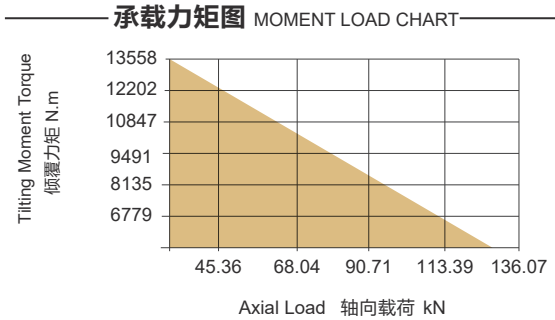

安装孔选项 Mounting Holes Option

Code 代码	M (Outer Ring 外圈)	N (Inner Ring 内圈)
—	M12×1.75 Tap (攻深)25	M12×1.75 Tap (攻深)25
T	M12×1.75 Tap (攻深)25	Ø14 Thru (通孔)
B	1/2"-13UNC-2B Tap (攻深)25	1/2"-13UNC-2B Tap (攻深)25
BT	1/2"-13UNC-2B Tap (攻深)25	Ø14 Thru (通孔)

性能参数表 Slewing Drive Performance Parameters

Model	Output Torque	Tilting Moment Torque	Holding Torque	Static Axial Rating	Static Radial Rating	Dynamic Axial Rating	Dynamic Radial Rating	Gear Ratio	Tracking Precision	Weight
SE7A	1500 N.m	13500 N.m	10400 N.m	133 kN	53 kN	32 kN	28 kN	73 : 1	≤ 0.2°	25 kg
	1107 lbf.ft	9957 lbf.ft	7671 lbf.ft	29900 lbf	11915 lbf	7194 lbf	6295 lbf			
PE7A	1500 N.m	13500 N.m	10400 N.m	133 kN	53 kN	32 kN	28 kN	73 : 1	≤ 0.11°	25 kg
	1107 lbf.ft	9957 lbf.ft	7671 lbf.ft	29900 lbf	11915 lbf	7194 lbf	6295 lbf			

"A" VIEW AS INPUT IS ALLOWED
输入端允许在 "A" 向视图

SPECIAL DESIGN BASE ON CUSTOMER'S REQUIREMENT
可根据顾客的要求进行非标设计

NOTICE 注意

- Please be sure to remain under the curve. 选型时请确保实际载荷在曲线范围内。
- This drawing is just for your reference. 以上图纸仅供参考。
- This drawing is subject to change due to new design without prior notice. 本公司保留改进产品的权利而不再另行通知。
- Please contact the technical department for dimensions and performance parameters of the drives. 如果需要装置的外形尺寸和性能参数, 请与技术部门联系。

SE9A-PE9A



UNITS/单位:mm
1inch=25.4mm
Weight:49kg

FRONT VIEW
正视图

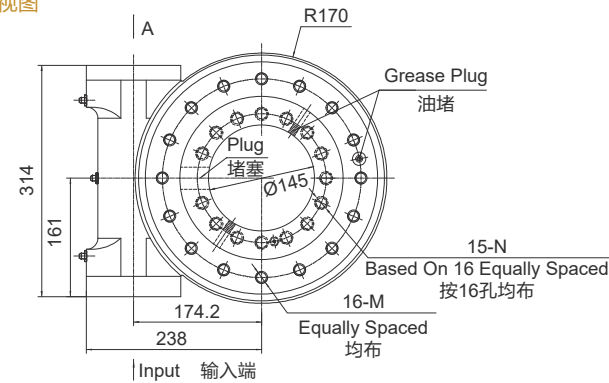

SIDE VIEW
侧视图

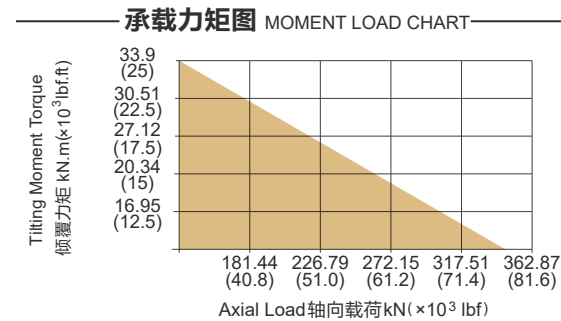
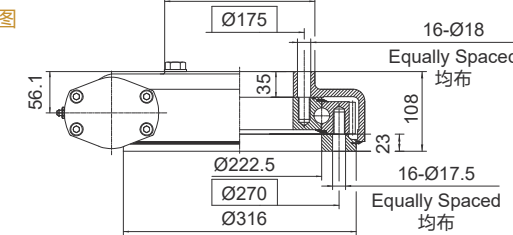

性能参数表 Slewing Drive Performance Parameters

Model	Output Torque	Tilting Moment Torque	Holding Torque	Static Axial Rating	Static Radial Rating	Dynamic Axial Rating	Dynamic Radial Rating	Gear Ratio	Tracking Precision	Weight
SE9A	6.5 kN.m	33.9 kN.m	34.5 kN.m	338 kN	135 kN	81 kN	71 kN	61 : 1	≤ 0.17°	49 kg
	4794 lbf.ft	25×10³ lbf.ft	25.5×10³ lbf.ft	76×10³ lbf	30×10³ lbf	18×10³ lbf	16×10³ lbf			
PE9A	6.5 kN.m	33.9 kN.m	34.5 kN.m	338 kN	135 kN	81 kN	71 kN	61 : 1	≤ 0.09°	49 kg
	4794 lbf.ft	25×10³ lbf.ft	25.5×10³ lbf.ft	76×10³ lbf	30×10³ lbf	18×10³ lbf	16×10³ lbf			

"A" VIEW AS INPUT IS ALLOWED
输入端允许在 "A" 向视图

SPECIAL DESIGN BASE ON CUSTOMER'S REQUIREMENT
可根据顾客的要求进行非标设计

NOTICE 注意

- Please be sure to remain under the curve. 选型时请确保实际载荷在曲线范围内。
- This drawing is just for your reference. 以上图纸仅供参考。
- This drawing is subject to change due to new design without prior notice. 本公司保留改进产品的权利而不再另行通知。
- Please contact the technical department for dimensions and performance parameters of the drives. 如果需要装置的外形尺寸和性能参数, 请与技术部门联系。

SE12A-PE12A

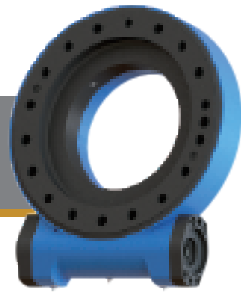

UNITS/单位:mm
1inch=25.4mm
Weight:61kg

FRONT VIEW
正视图

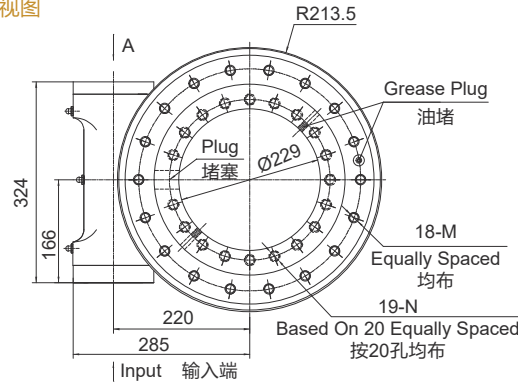

SIDE VIEW
侧视图

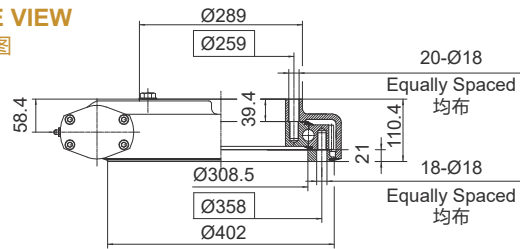

承载力矩图 MOMENT LOAD CHART

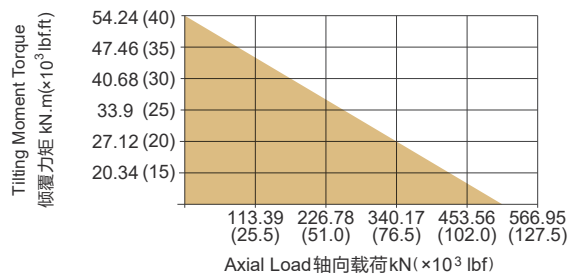

INPUT 输入端视图

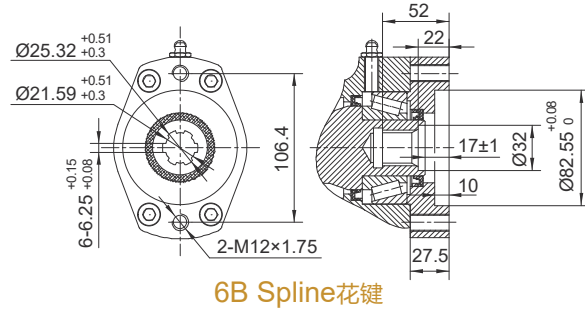
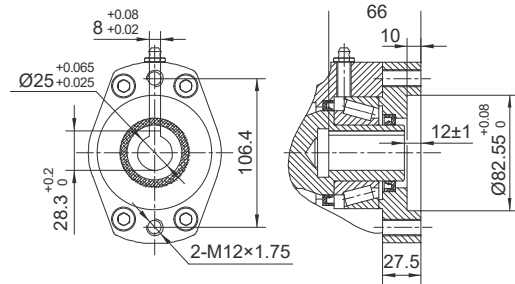

安装孔选项 Mounting Holes Option

Code 代码	M (Outer Ring 外圈)	N (Inner Ring 内圈)
—	M16×2 Tap (攻深)30	M16×2 Tap (攻深)30
T	M16×2 Tap (攻深)30	Ø18 Thru (通孔)
B	5/8"-11UNC-2B Tap (攻深)30	5/8"-11UNC-2B Tap (攻深)30
BT	5/8"-11UNC-2B Tap (攻深)30	Ø18Thru (通孔)

性能参数表 Slewing Drive Performance Parameters

Model	Output Torque	Tilting Moment Torque	Holding Torque	Static Axial Rating	Static Radial Rating	Dynamic Axial Rating	Dynamic Radial Rating	Gear Ratio	Tracking Precision	Weight
SE12A	7.5 kN.m 5532 lbf.ft	54.3 kN.m 40×10³ lbf.ft	43 kN.m 32×10³ lbf.ft	475 kN 107×10³ lbf	190 kN 43×10³ lbf	114 kN 26×10³ lbf	100 kN 23×10³ lbf	78 : 1	≤ 0.17°	61 kg
PE12A	7.5 kN.m 5532 lbf.ft	54.3 kN.m 40×10³ lbf.ft	43 kN.m 32×10³ lbf.ft	475 kN 107×10³ lbf	190 kN 43×10³ lbf	114 kN 26×10³ lbf	100 kN 23×10³ lbf	78 : 1	≤ 0.07°	61 kg

"A" VIEW AS INPUT IS ALLOWED
输入端允许在 "A" 向视图

SPECIAL DESIGN BASE ON CUSTOMER'S REQUIREMENT
可根据顾客的要求进行非标设计

NOTICE
Please be sure to remain under the curve. 选型时请确保实际载荷在曲线范围内。
This drawing is just for your reference. 以上图纸仅供参考。
This drawing is subject to change due to new design without prior notice. 本公司保留改进产品的权利而不再另行通知。
Please contact the technical department for dimensions and performance parameters of the drives. 如果需要装置的外形尺寸和性能参数, 请与技术部门联系。

SE14A-PE14A

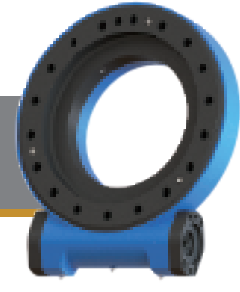

UNITS/单位:mm
1inch=25.4mm
Weight:64kg

FRONT VIEW
正视图

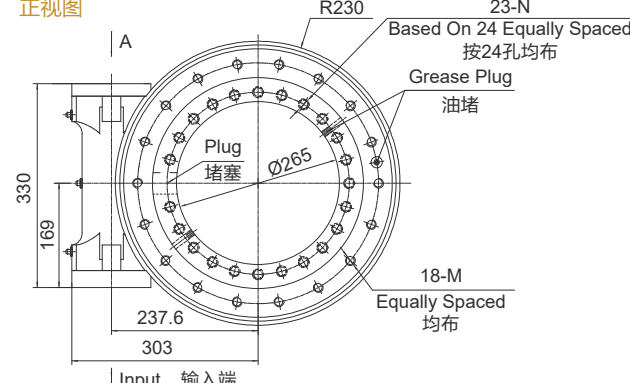

SIDE VIEW
侧视图

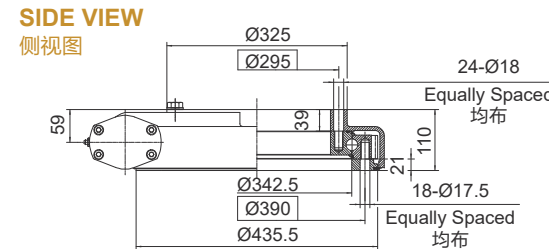

承载力矩图 MOMENT LOAD CHART

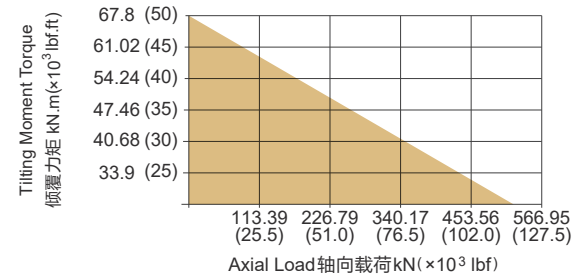

INPUT 输入端视图

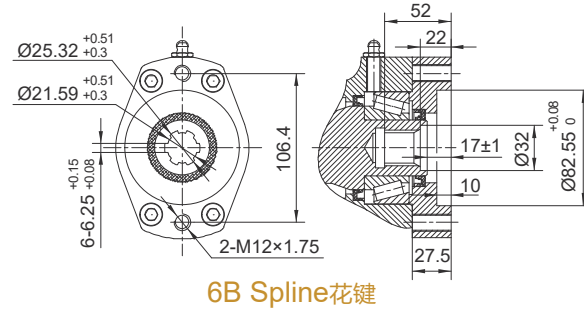
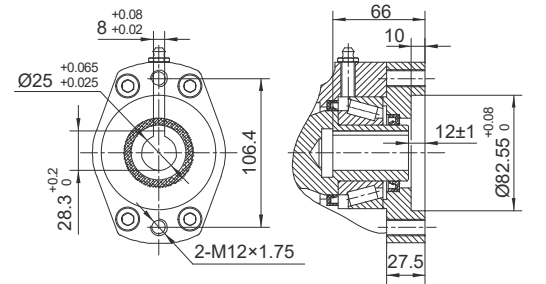

安装孔选项 Mounting Holes Option

Code 代码	M (Outer Ring 外圈)	N (Inner Ring 内圈)
—	M16×2 Tap (攻深)30	M16×2 Tap (攻深)30
T	M16×2 Tap (攻深)30	Ø18 Thru (通孔)
B	5/8"-11UNC-2B Tap (攻深)30	5/8"-11UNC-2B Tap (攻深)30
BT	5/8"-11UNC-2B Tap (攻深)30	Ø18Thru (通孔)

性能参数表 Slewing Drive Performance Parameters

Model	Output Torque	Tilting Moment Torque	Holding Torque	Static Axial Rating	Static Radial Rating	Dynamic Axial Rating	Dynamic Radial Rating	Gear Ratio	Tracking Precision	Weight
SE14A	8 kN.m 5900 lbf.ft	67.8 kN.m 50×10³ lbf.ft	48 kN.m 35×10³ lbf.ft	555 kN 125×10³ lbf	222 kN 50×10³ lbf	133 kN 30×10³ lbf	117 kN 26×10³ lbf	85 : 1	≤ 0.17°	64 kg
PE14A	8 kN.m 5900 lbf.ft	67.8 kN.m 50×10³ lbf.ft	48 kN.m 35×10³ lbf.ft	555 kN 125×10³ lbf	222 kN 50×10³ lbf	133 kN 30×10³ lbf	117 kN 26×10³ lbf	85 : 1	≤ 0.09°	64 kg

"A" VIEW AS INPUT IS ALLOWED
输入端允许在 "A" 向视图

SPECIAL DESIGN BASE ON CUSTOMER'S REQUIREMENT
可根据顾客的要求进行非标设计

NOTICE
Please be sure to remain under the curve. 选型时请确保实际载荷在曲线范围内。
This drawing is just for your reference. 以上图纸仅供参考。
This drawing is subject to change due to new design without prior notice. 本公司保留改进产品的权利而不再另行通知。
Please contact the technical department for dimensions and performance parameters of the drives. 如果需要装置的外形尺寸和性能参数, 请与技术部门联系。

SE17A-PE17A

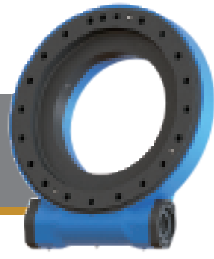

UNITS/单位:mm
1inch=25.4mm
Weight:105kg

FRONT VIEW
正视图

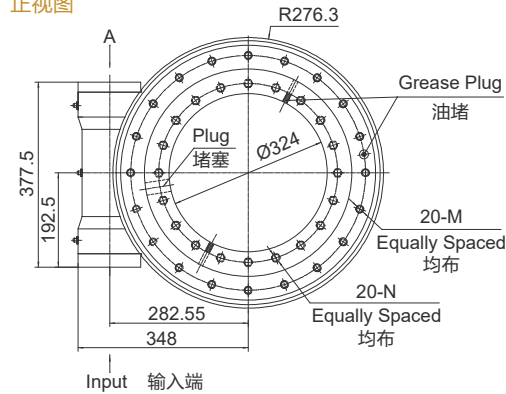

INPUT 输入端视图

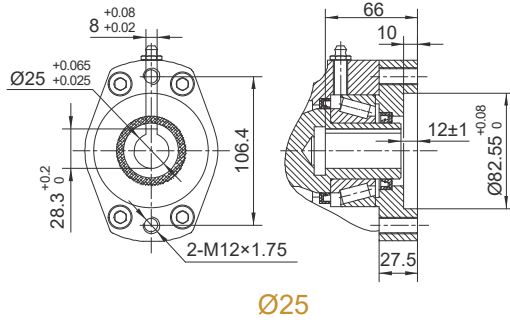

SIDE VIEW
侧视图

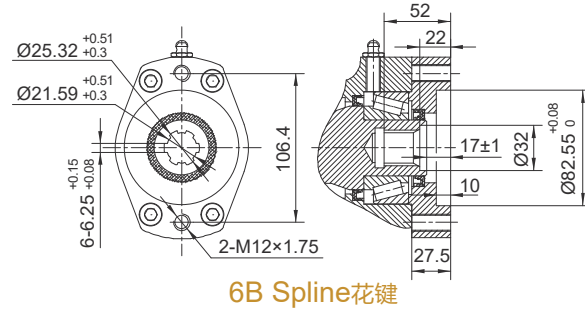
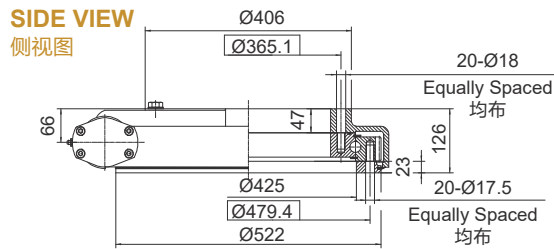

承载力矩图 MOMENT LOAD CHART

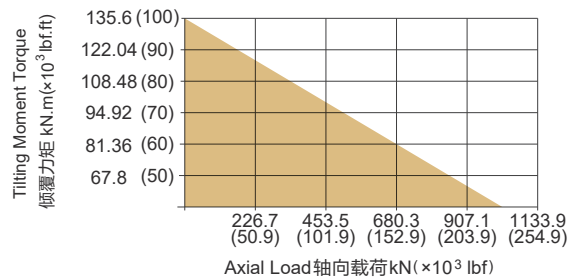

安装孔选项 Mounting Holes Option

Code 代码	M (Outer Ring 外圈)	N (Inner Ring 内圈)
—	M16x2 Tap (攻深)32	M16x2 Tap (攻深)32
T	M16x2 Tap (攻深)32	Ø18 Thru (通孔)
B	5/8"-11UNC-2B Tap (攻深)32	5/8"-11UNC-2B Tap (攻深)32
BT	5/8"-11UNC-2B Tap (攻深)32	Ø18 Thru (通孔)

性能参数表 Slewing Drive Performance Parameters

Model	Output Torque	Tilting Moment Torque	Holding Torque	Static Axial Rating	Static Radial Rating	Dynamic Axial Rating	Dynamic Radial Rating	Gear Ratio	Tracking Precision	Weight
SE17A	10 kN.m	135.6 kN.m	58 kN.m	970 kN	390 kN	235 kN	205 kN	102 : 1	≤ 0.15°	105 kg
	7400 lbf.ft	100×10 ³ lbf.ft	42.8×10 ³ lbf.ft	218×10 ³ lbf	88×10 ³ lbf	53×10 ³ lbf	46×10 ³ lbf			
PE17A	10 kN.m	135.6 kN.m	58 kN.m	970 kN	390 kN	235 kN	205 kN	102 : 1	≤ 0.09°	105 kg
	7400 lbf.ft	100×10 ³ lbf.ft	42.8×10 ³ lbf.ft	218×10 ³ lbf	88×10 ³ lbf	53×10 ³ lbf	46×10 ³ lbf			

"A" VIEW AS INPUT IS ALLOWED
输入端允许在 "A" 向视图

SPECIAL DESIGN BASE ON CUSTOMER'S REQUIREMENT
可根据顾客的要求进行非标设计

- NOTICE 注意
- Please be sure to remain under the curve. 选型时请确保实际载荷在曲线范围内。
 - This drawing is just for your reference. 以上图纸仅供参考。
 - This drawing is subject to change due to new design without prior notice. 本公司保留改进产品的权利而不再另行通知。
 - Please contact the technical department for dimensions and performance parameters of the drives. 如果需要装置的外形尺寸和性能参数, 请与技术部门联系。

SE21-PE21

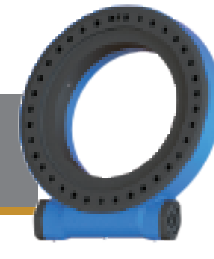

UNITS/单位:mm
1inch=25.4mm
Weight:149kg

FRONT VIEW
正视图

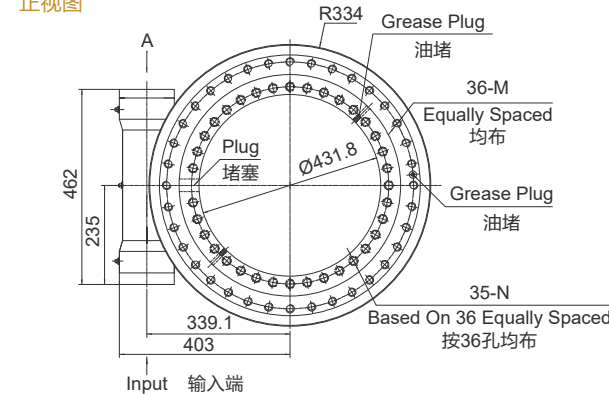

INPUT 输入端视图

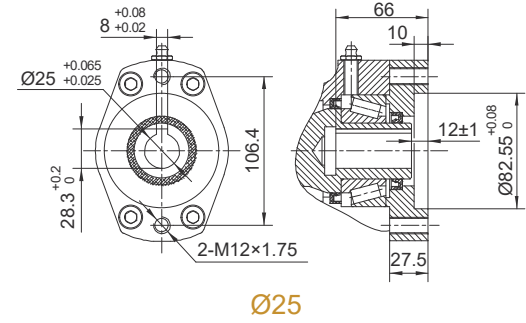

SIDE VIEW
侧视图

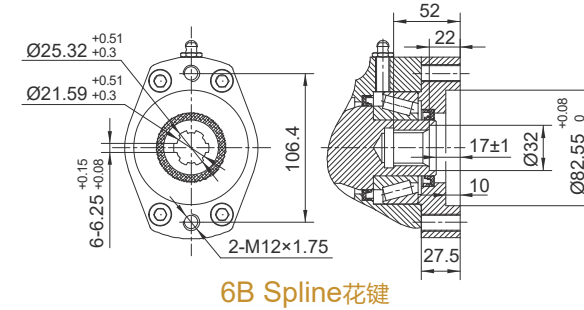
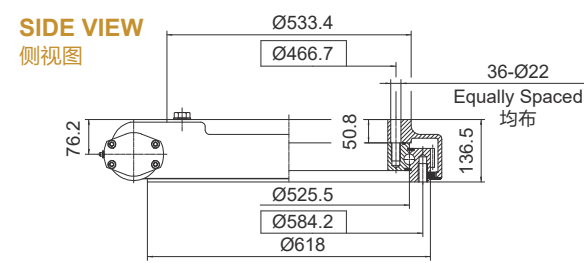

承载力矩图 MOMENT LOAD CHART

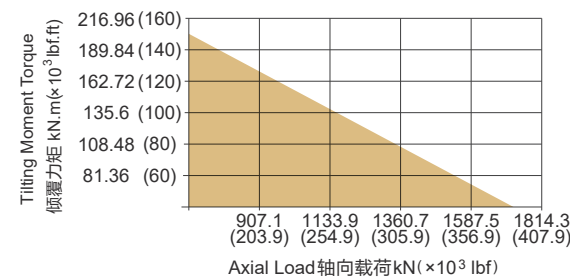

安装孔选项 Mounting Holes Option

Code 代码	M (Outer Ring 外圈)	N (Inner Ring 内圈)
—	M20x2.5 Tap (攻深)40	M20x2.5 Tap (攻深)40
T	M20x2.5 Tap (攻深)40	Ø22 Thru (通孔)
B	3/4"-10UNC-2B Tap (攻深)40	3/4"-10UNC-2B Tap (攻深)40
BT	3/4"-10UNC-2B Tap (攻深)40	Ø22 Thru (通孔)

性能参数表 Slewing Drive Performance Parameters

Model	Output Torque	Tilting Moment Torque	Holding Torque	Static Axial Rating	Static Radial Rating	Dynamic Axial Rating	Dynamic Radial Rating	Gear Ratio	Tracking Precision	Weight
SE21	15 kN.m	203 kN.m	70.5 kN.m	1598 kN	640 kN	385 kN	335 kN	125 : 1	≤ 0.15°	149 kg
	11000 lbf.ft	150×10 ³ lbf.ft	52×10 ³ lbf.ft	359×10 ³ lbf	144×10 ³ lbf	87×10 ³ lbf	75×10 ³ lbf			
PE21	15 kN.m	203 kN.m	105.8 kN.m	1598 kN	640 kN	385 kN	335 kN	125 : 1	≤ 0.09°	149 kg
	11000 lbf.ft	150×10 ³ lbf.ft	78×10 ³ lbf.ft	359×10 ³ lbf	144×10 ³ lbf	87×10 ³ lbf	75×10 ³ lbf			

"A" VIEW AS INPUT IS ALLOWED
输入端允许在 "A" 向视图

SPECIAL DESIGN BASE ON CUSTOMER'S REQUIREMENT
可根据顾客的要求进行非标设计

- NOTICE 注意
- Please be sure to remain under the curve. 选型时请确保实际载荷在曲线范围内。
 - This drawing is just for your reference. 以上图纸仅供参考。
 - This drawing is subject to change due to new design without prior notice. 本公司保留改进产品的权利而不再另行通知。
 - Please contact the technical department for dimensions and performance parameters of the drives. 如果需要装置的外形尺寸和性能参数, 请与技术部门联系。

SE25-PE25



UNITS/单位:mm
1inch=25.4mm
Weight:204kg

FRONT VIEW
正视图

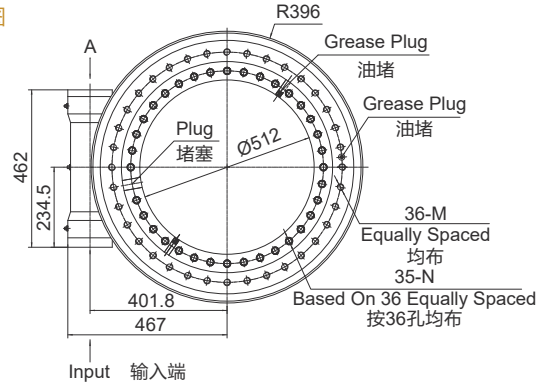

INPUT 输入端视图

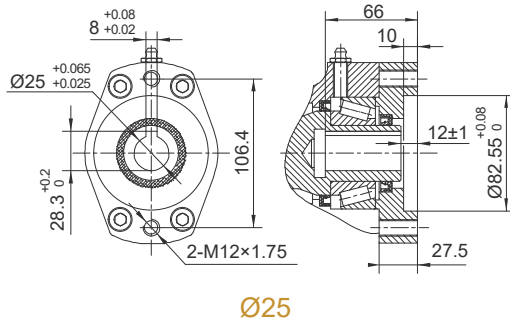

SIDE VIEW
侧视图

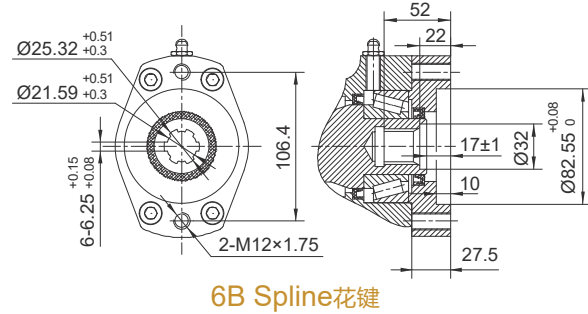
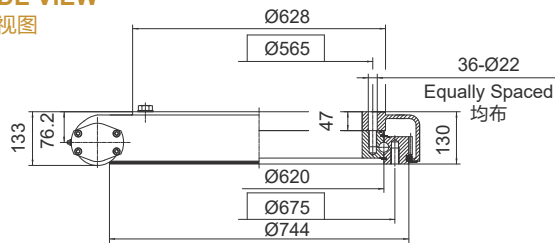

6B Spline花键

承载力矩图 MOMENT LOAD CHART

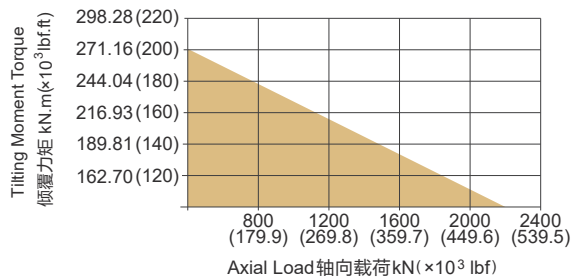

安装孔选项 Mounting Holes Option

Code 代码	M (Outer Ring 外圈)	N (Inner Ring 内圈)
—	M20×2.5 Tap (攻深)40	M20×2.5 Tap (攻深)40
T	M20×2.5 Tap (攻深)40	Ø22 Thru (通孔)
B	3/4"-10UNC-2B Tap (攻深)40	3/4"-10UNC-2B Tap (攻深)40
BT	3/4"-10UNC-2B Tap (攻深)40	Ø22 Thru (通孔)

性能参数表 Slewing Drive Performance Parameters

Model	Output Torque	Tilting Moment Torque	Holding Torque	Static Axial Rating	Static Radial Rating	Dynamic Axial Rating	Dynamic Radial Rating	Gear Ratio	Tracking Precision	Weight
SE25	18 kN.m	271 kN.m	84.5 kN.m	2360 kN	945 kN	590 kN	470 kN	150 : 1	≤ 0.15°	204 kg
	13300 lbf.ft	200×10 ³ lbf.ft	62.4×10 ³ lbf.ft	531×10 ³ lbf	212×10 ³ lbf	133×10 ³ lbf	106×10 ³ lbf			
PE25	18kN.m	271 kN.m	84.5 kN.m	2360 kN	945 kN	590 kN	470 kN	150 : 1	≤ 0.09°	204 kg
	13300 lbf.ft	200×10 ³ lbf.ft	62.4×10 ³ lbf.ft	531×10 ³ lbf	212×10 ³ lbf	133×10 ³ lbf	106×10 ³ lbf			

"A" VIEW AS INPUT IS ALLOWED
输入端允许在 "A" 向视图

SPECIAL DESIGN BASE ON CUSTOMER'S REQUIREMENT
可根据顾客的要求进行非标设计



• Please be sure to remain under the curve. 选型时请确保实际载荷在曲线范围内。
• This drawing is just for your reference. 以上图纸仅供参考。
• This drawing is subject to change due to new design without prior notice. 本公司保留改进产品的权利而不再另行通知。
• Please contact the technical department for dimensions and performance parameters of the drives. 如果需要装置的外形尺寸和性能参数, 请与技术部门联系。

SEA9/PEA9

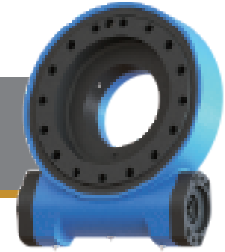

UNITS/单位:mm
1inch=25.4mm
Weight:48kg

FRONT VIEW
正视图

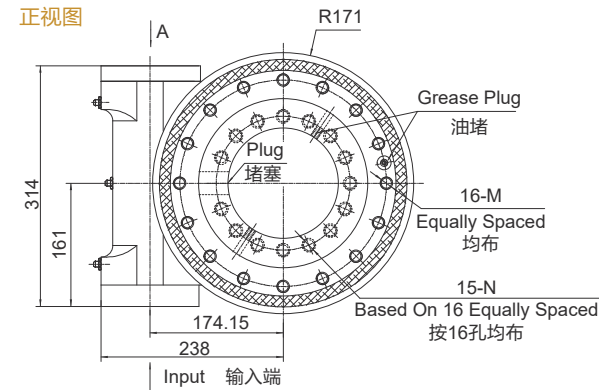

INPUT 输入端视图

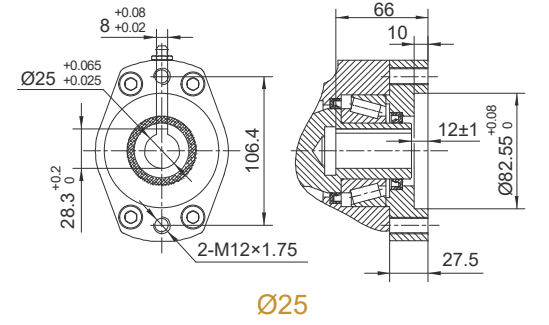

SIDE VIEW
侧视图

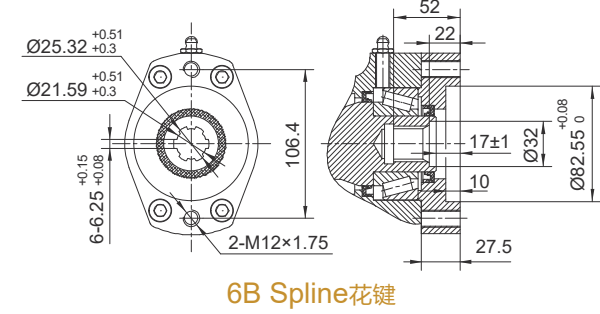
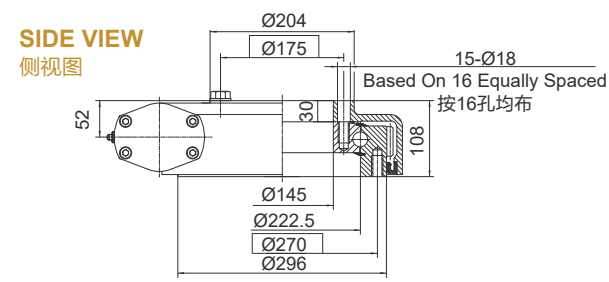

6B Spline花键

承载力矩图 MOMENT LOAD CHART

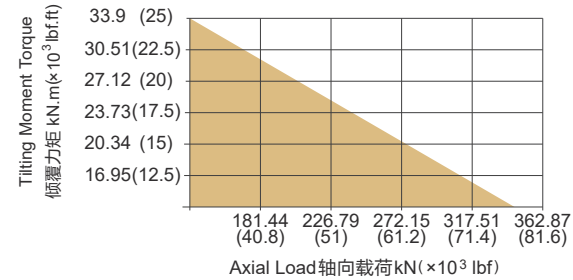

安装孔选项 Mounting Holes Option

Code 代码	M (Outer Ring 外圈)	N (Inner Ring 内圈)
—	M16×2 Tap (攻深)30	M16×2 Tap (攻深)30
T	M16×2 Tap (攻深)30	Ø18 Thru (通孔)
B	5/8"-11UNC-2B Tap (攻深)30	5/8"-11UNC-2B Tap (攻深)30
BT	5/8"-11UNC-2B Tap (攻深)30	Ø18 Thru (通孔)

性能参数表 Slewing Drive Performance Parameters

Model	Output Torque	Tilting Moment Torque	Holding Torque	Static Axial Rating	Static Radial Rating	Dynamic Axial Rating	Dynamic Radial Rating	Gear Ratio	Tracking Precision	Weight
SEA9	6.5 kN.m	33.9 kN.m	34.5 kN.m	338 kN	135 kN	81 kN	71 kN	61 : 1	≤ 0.17°	48 kg
	4794 lbf.ft	25×10 ³ lbf.ft	25.5×10 ³ lbf.ft	76×10 ³ lbf	30×10 ³ lbf	18×10 ³ lbf	16×10 ³ lbf			
PEA9	6.5 kN.m	33.9 kN.m	34.5 kN.m	338 kN	135 kN	81 kN	71 kN	61 : 1	≤ 0.09°	48 kg
	4794 lbf.ft	25×10 ³ lbf.ft	25.5×10 ³ lbf.ft	76×10 ³ lbf	30×10 ³ lbf	18×10 ³ lbf	16×10 ³ lbf			

"A" VIEW AS INPUT IS ALLOWED
输入端允许在 "A" 向视图

SPECIAL DESIGN BASE ON CUSTOMER'S REQUIREMENT
可根据顾客的要求进行非标设计



• Please be sure to remain under the curve. 选型时请确保实际载荷在曲线范围内。
• This drawing is just for your reference. 以上图纸仅供参考。
• This drawing is subject to change due to new design without prior notice. 本公司保留改进产品的权利而不再另行通知。
• Please contact the technical department for dimensions and performance parameters of the drives. 如果需要装置的外形尺寸和性能参数, 请与技术部门联系。

SEA12/PEA12



UNITS/单位:mm
1inch=25.4mm
Weight:63kg

FRONT VIEW
正视图

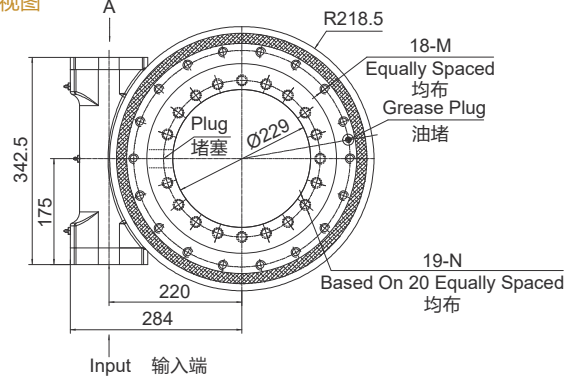

INPUT 输入端视图

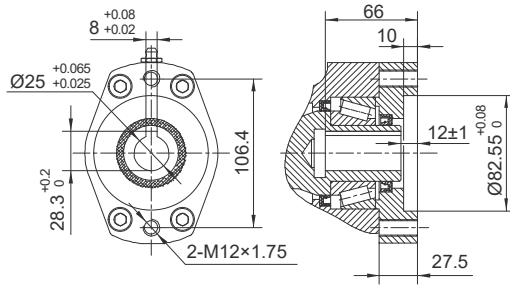

SIDE VIEW
侧视图

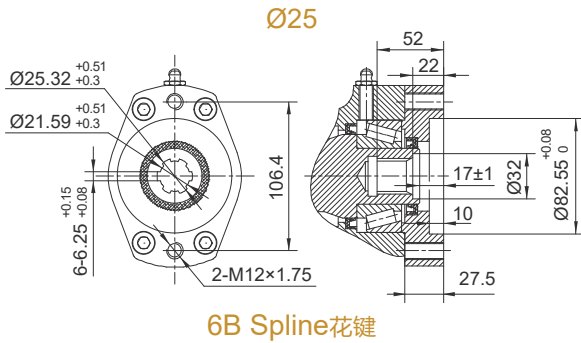
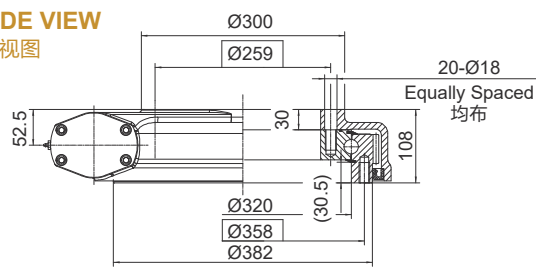

承载力矩图 MOMENT LOAD CHART

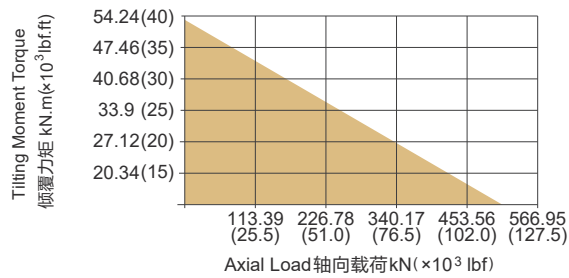

安装孔选项 Mounting Holes Option

Code 代码	M (Outer Ring 外圈)	N (Inner Ring 内圈)
—	M16x2 Tap (攻深)30	M16x2 Tap (攻深)30
T	M16x2 Tap (攻深)30	Ø18 Thru (通孔)
B	5/8"-11UNC-2B Tap (攻深)30	5/8"-11UNC-2B Tap (攻深)30
BT	5/8"-11UNC-2B Tap (攻深)30	Ø18 Thru (通孔)

性能参数表 Slewing Drive Performance Parameters

Model	Output Torque	Tilting Moment Torque	Holding Torque	Static Axial Rating	Static Radial Rating	Dynamic Axial Rating	Dynamic Radial Rating	Gear Ratio	Tracking Precision	Weight
SEA12	7.5 kN.m 5532 lbf.ft	54.3 kN.m 40x10³ lbf.ft	43 kN.m 32x10³ lbf.ft	475 kN 107x10³ lbf	190 kN 43x10³ lbf	114 kN 26x10³ lbf	100 kN 23x10³ lbf	78 : 1	≤ 0.17°	63 kg
PEA12	7.5 kN.m 5532 lbf.ft	54.3 kN.m 40x10³ lbf.ft	43 kN.m 32x10³ lbf.ft	475 kN 107x10³ lbf	190 kN 43x10³ lbf	114 kN 26x10³ lbf	100 kN 23x10³ lbf	78 : 1	≤ 0.07°	63 kg

"A" VIEW AS INPUT IS ALLOWED
输入端允许在 "A" 向视图

SPECIAL DESIGN BASE ON CUSTOMER'S REQUIREMENT
可根据顾客的要求进行非标设计

NOTICE
Please be sure to remain under the curve. 选型时请确保实际载荷在曲线范围内。
This drawing is just for your reference. 以上图纸仅供参考。
This drawing is subject to change due to new design without prior notice. 本公司保留改进产品的权利而不再另行通知。
Please contact the technical department for dimensions and performance parameters of the drives. 如果需要装置的外形尺寸和性能参数, 请与技术部门联系。

SEA14/PEA14



UNITS/单位:mm
1inch=25.4mm
Weight:68kg

FRONT VIEW
正视图

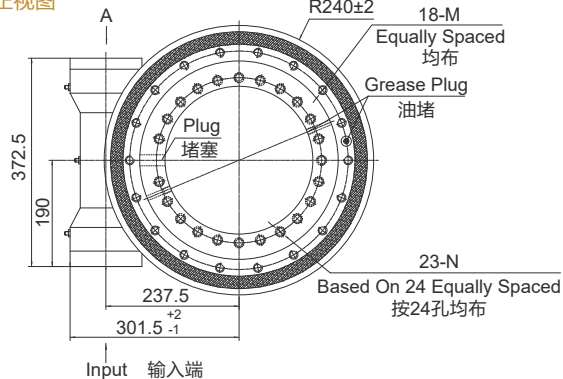

INPUT 输入端视图

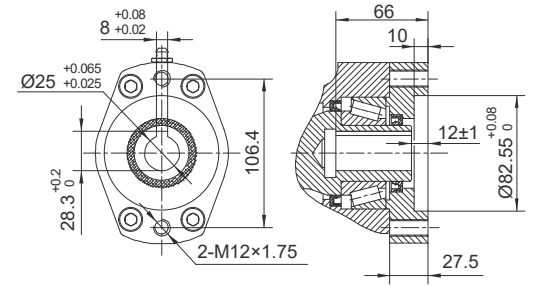

SIDE VIEW
侧视图

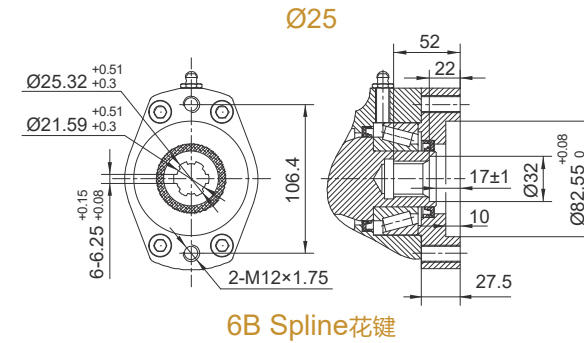
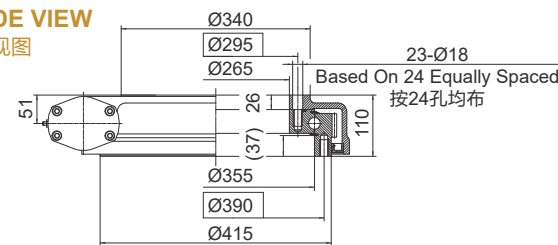

承载力矩图 MOMENT LOAD CHART

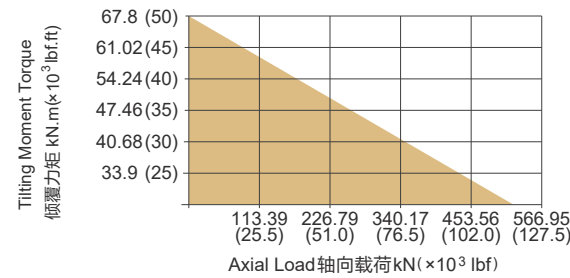

安装孔选项 Mounting Holes Option

Code 代码	M (Outer Ring 外圈)	N (Inner Ring 内圈)
—	M16x2 Tap (攻深)30	M16x2 Tap (攻深)30
T	M16x2 Tap (攻深)30	Ø18 Thru (通孔)
B	5/8"-11UNC-2B Tap (攻深)30	5/8"-11UNC-2B Tap (攻深)30
BT	5/8"-11UNC-2B Tap (攻深)30	Ø18 Thru (通孔)

性能参数表 Slewing Drive Performance Parameters

Model	Output Torque	Tilting Moment Torque	Holding Torque	Static Axial Rating	Static Radial Rating	Dynamic Axial Rating	Dynamic Radial Rating	Gear Ratio	Tracking Precision	Weight
SEA14	8 kN.m 5900 lbf.ft	67.8 kN.m 50x10³ lbf.ft	48 kN.m 35x10³ lbf.ft	555 kN 125x10³ lbf	222 kN 50x10³ lbf	133 kN 30x10³ lbf	117 kN 26x10³ lbf	85 : 1	≤ 0.17°	68 kg
PEA14	8 kN.m 5900 lbf.ft	67.8 kN.m 50x10³ lbf.ft	48 kN.m 35x10³ lbf.ft	555 kN 125x10³ lbf	222 kN 50x10³ lbf	133 kN 30x10³ lbf	117 kN 26x10³ lbf	85 : 1	≤ 0.09°	68 kg

"A" VIEW AS INPUT IS ALLOWED
输入端允许在 "A" 向视图

SPECIAL DESIGN BASE ON CUSTOMER'S REQUIREMENT
可根据顾客的要求进行非标设计

NOTICE
Please be sure to remain under the curve. 选型时请确保实际载荷在曲线范围内。
This drawing is just for your reference. 以上图纸仅供参考。
This drawing is subject to change due to new design without prior notice. 本公司保留改进产品的权利而不再另行通知。
Please contact the technical department for dimensions and performance parameters of the drives. 如果需要装置的外形尺寸和性能参数, 请与技术部门联系。

SEA17C/PEA17C

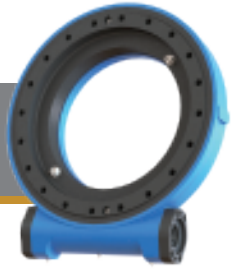

UNITS/单位:mm
1inch=25.4mm
Weight:88kg

FRONT VIEW
正视图

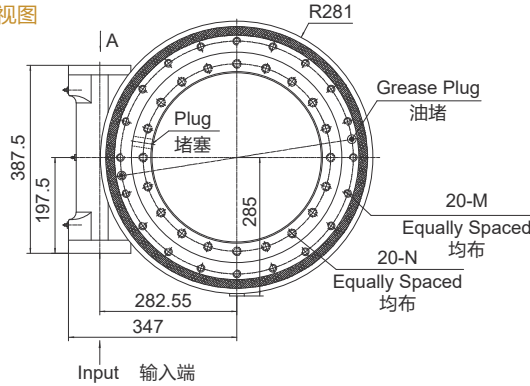

INPUT 输入端视图

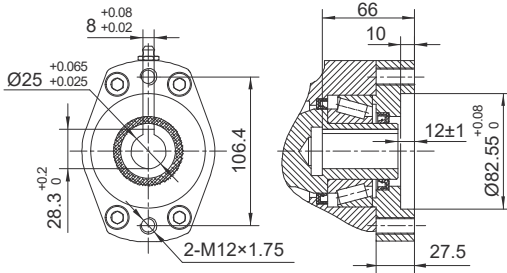

SIDE VIEW
侧视图

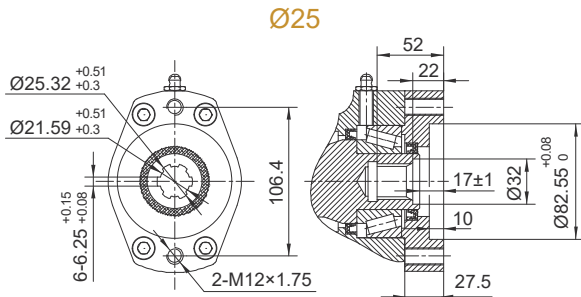
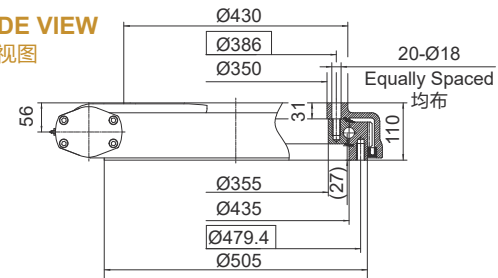

6B Spline花键

承载力矩图 MOMENT LOAD CHART

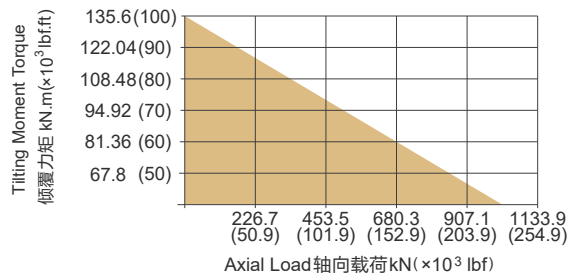

安装孔选项 Mounting Holes Option

Code 代码	M (Outer Ring 外圈)	N (Inner Ring 内圈)
—	M16×2 Tap (攻深)32	M16×2 Tap (攻深)32
T	M16×2 Tap (攻深)32	Ø18 Thru (通孔)
B	5/8"-11UNC-2B Tap (攻深)32	5/8"-11UNC-2B Tap (攻深)32
BT	5/8"-11UNC-2B Tap (攻深)32	Ø18 Thru (通孔)

性能参数表 Slewing Drive Performance Parameters

Model	Output Torque	Tilting Moment Torque	Holding Torque	Static Axial Rating	Static Radial Rating	Dynamic Axial Rating	Dynamic Radial Rating	Gear Ratio	Tracking Precision	Weight
SEA 17C	10 kN.m 7400 lbf.ft	135.6 kN.m 100×10³ lbf.ft	58 kN.m 42.8×10³ lbf.ft	970 kN 218×10³ lbf	390 kN 88×10³ lbf	235 kN 53×10³ lbf	205 kN 46×10³ lbf	102 : 1	≤ 0.15°	88 kg
PEA 17C	10 kN.m 7400 lbf.ft	135.6 kN.m 100×10³ lbf.ft	58 kN.m 42.8×10³ lbf.ft	970 kN 218×10³ lbf	390 kN 88×10³ lbf	235 kN 53×10³ lbf	205 kN 46×10³ lbf	102 : 1	≤ 0.09°	88 kg

"A" VIEW AS INPUT IS ALLOWED
输入端允许在 "A" 向视图

SPECIAL DESIGN BASE ON CUSTOMER'S REQUIREMENT
可根据顾客的要求进行非标设计

NOTICE
Please be sure to remain under the curve. 选型时请确保实际载荷在曲线范围内。
This drawing is just for your reference. 以上图纸仅供参考。
This drawing is subject to change due to new design without prior notice. 本公司保留改进产品的权利而不再另行通知。
Please contact the technical department for dimensions and performance parameters of the drives. 如果需要装置的外形尺寸和性能参数, 请与技术部门联系。

SEA21/PEA21



UNITS/单位:mm
1inch=25.4mm
Weight:140kg

FRONT VIEW
正视图

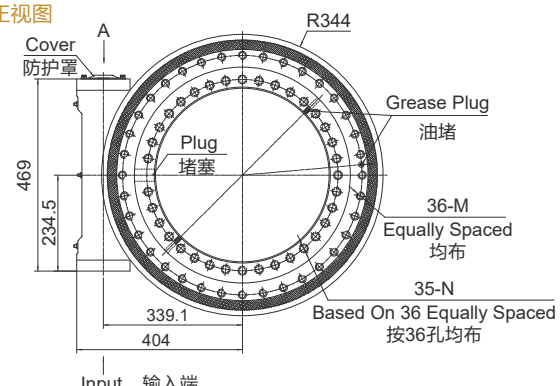

INPUT 输入端视图

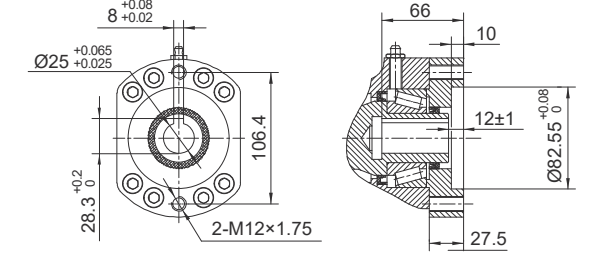

SIDE VIEW
侧视图

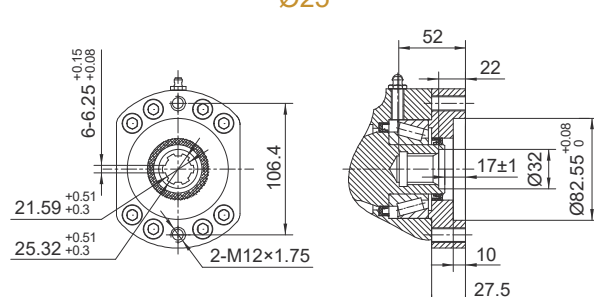
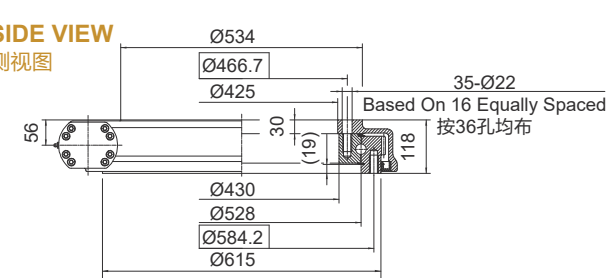

6B Spline花键

承载力矩图 MOMENT LOAD CHART

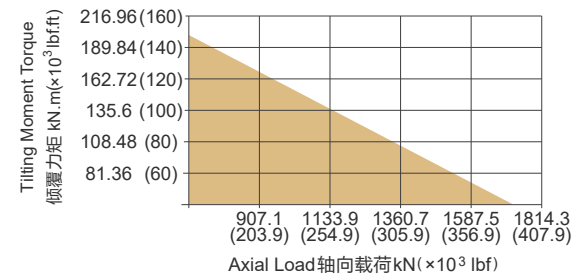

安装孔选项 Mounting Holes Option

Code 代码	M (Outer Ring 外圈)	N (Inner Ring 内圈)
—	M20×2.5 Tap (攻深)40	M20×2.5 Tap (攻深)40
T	M20×2.5 Tap (攻深)40	Ø22 Thru (通孔)
B	3/4"-10UNC-2B Tap (攻深)40	3/4"-10UNC-2B Tap (攻深)40
BT	3/4"-10UNC-2B Tap (攻深)40	Ø22 Thru (通孔)

性能参数表 Slewing Drive Performance Parameters

Model	Output Torque	Tilting Moment Torque	Holding Torque	Static Axial Rating	Static Radial Rating	Dynamic Axial Rating	Dynamic Radial Rating	Gear Ratio	Tracking Precision	Weight
SEA21	15 kN.m 11000 lbf.ft	203 kN.m 150×10³ lbf.ft	70.5 kN.m 52×10³ lbf.ft	1598 kN 359×10³ lbf	640 kN 144×10³ lbf	385 kN 87×10³ lbf	335 kN 75×10³ lbf	125 : 1	≤ 0.15°	140 kg
PEA21	15 kN.m 11000 lbf.ft	203 N.m 150×10³ lbf.ft	70.5 kN.m 52×10³ lbf.ft	1598 kN 359×10³ lbf	640 kN 144×10³ lbf	385 kN 87×10³ lbf	335 kN 75×10³ lbf	125 : 1	≤ 0.09°	140 kg

"A" VIEW AS INPUT IS ALLOWED
输入端允许在 "A" 向视图

SPECIAL DESIGN BASE ON CUSTOMER'S REQUIREMENT
可根据顾客的要求进行非标设计

NOTICE
Please be sure to remain under the curve. 选型时请确保实际载荷在曲线范围内。
This drawing is just for your reference. 以上图纸仅供参考。
This drawing is subject to change due to new design without prior notice. 本公司保留改进产品的权利而不再另行通知。
Please contact the technical department for dimensions and performance parameters of the drives. 如果需要装置的外形尺寸和性能参数, 请与技术部门联系。

SEA25/PEA25



UNITS/单位:mm
1inch=25.4mm
Weight:165kg

FRONT VIEW
正视图

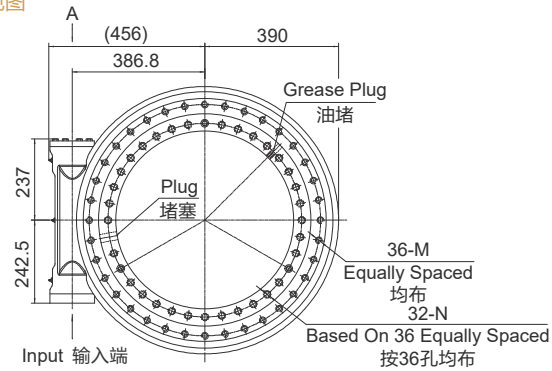

INPUT 输入端视图

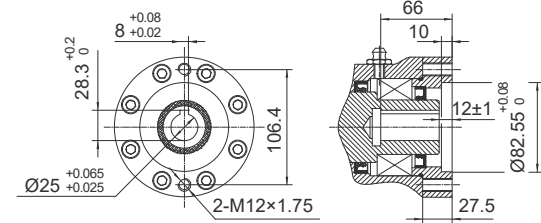

Ø25

SIDE VIEW
侧视图

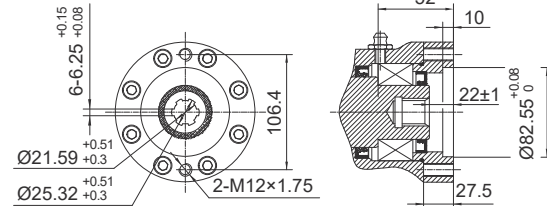
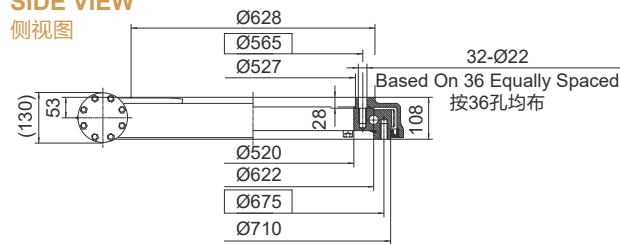

6B Spline花键

承载力矩图 MOMENT LOAD CHART

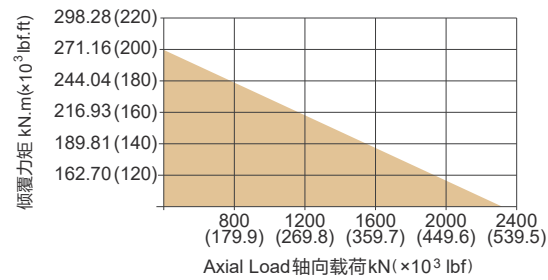

安装孔选项 Mounting Holes Option

Code 代码	M (Outer Ring 外圈)	N (Inner Ring 内圈)
—	M20×2.5 Tap (攻深)40	M20×2.5 Tap (攻深)40
T	M20×2.5 Tap (攻深)40	Ø22 Thru (通孔)
B	3/4"-10UNC-2B Tap (攻深)40	3/4"-10UNC-2B Tap (攻深)40
BT	3/4"-10UNC-2B Tap (攻深)40	Ø22 Thru (通孔)

性能参数表 Slewing Drive Performance Parameters

Model	Output Torque	Tilting Moment Torque	Holding Torque	Static Axial Rating	Static Radial Rating	Dynamic Axial Rating	Dynamic Radial Rating	Gear Ratio	Tracking Precision	Weight
类型	输出转矩	倾覆力矩	保持力矩	轴向静载荷	径向静载荷	轴向动载荷	径向动载荷	减速比	精度等级	重量
SEA25	18 kN.m 13300 lbf.ft	270 kN.m 200×10³ lbf.ft	84.5 kN.m 62.4×10³ lbf.ft	2360 kN 531×10³ lbf	945 kN 212×10³ lbf	590 kN 133×10³ lbf	470 kN 106×10³ lbf	150 : 1	≤ 0.15°	165 kg
PEA25	18 kN.m 13300 lbf.ft	270 kN.m 200×10³ lbf.ft	84.5 kN.m 62.4×10³ lbf.ft	2360 kN 531×10³ lbf	945 kN 212×10³ lbf	590 kN 133×10³ lbf	470 kN 106×10³ lbf	150 : 1	≤ 0.09°	165 kg

"A" VIEW AS INPUT IS ALLOWED
输入端允许在 "A" 向视图

SPECIAL DESIGN BASE ON CUSTOMER'S REQUIREMENT
可根据顾客的要求进行非标设计

NOTICE
Please be sure to remain under the curve. 选型时请确保实际载荷在曲线范围内。
This drawing is just for your reference. 以上图纸仅供参考。
This drawing is subject to change due to new design without prior notice. 本公司保留改进产品的权利而不再另行通知。
Please contact the technical department for dimensions and performance parameters of the drives. 如果需要装置的外形尺寸和性能参数, 请与技术部门联系。

SEB7/PEB7



UNITS/单位:mm
1inch=25.4mm
Weight:26kg

FRONT VIEW
正视图

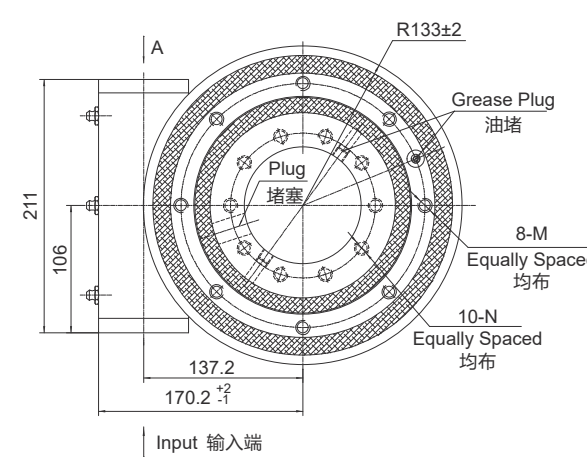

INPUT 输入端视图

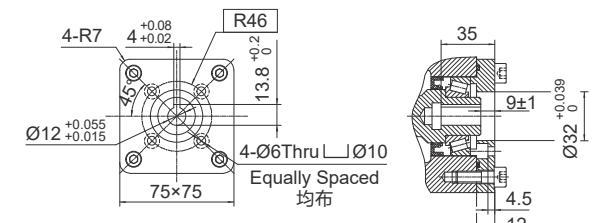

Ø12

SIDE VIEW
侧视图

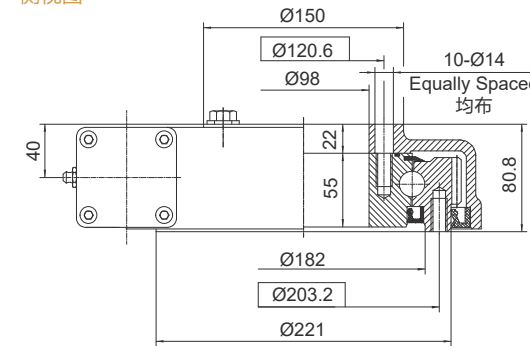

承载力矩图 MOMENT LOAD CHART

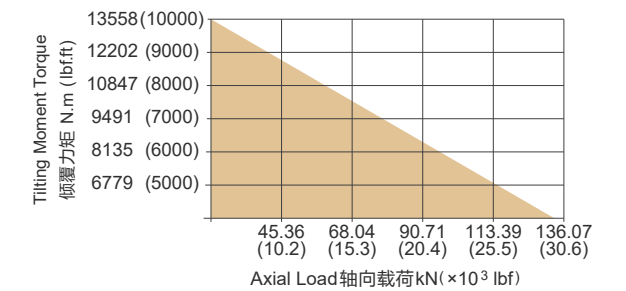

安装孔选项 Mounting Holes Option

Code 代码	M (Outer Ring 外圈)	N (Inner Ring 内圈)
—	M12×1.75 Tap (攻深)25	M12×1.75 Tap (攻深)25
T	M12×1.75 Tap (攻深)25	Ø14 Thru (通孔)
B	1/2"-13UNC-2B Tap (攻深)25	1/2"-13UNC-2B Tap (攻深)25
BT	1/2"-13UNC-2B Tap (攻深)25	Ø14 Thru (通孔)

性能参数表 Slewing Drive Performance Parameters

Model	Output Torque	Tilting Moment Torque	Holding Torque	Static Axial Rating	Static Radial Rating	Dynamic Axial Rating	Dynamic Radial Rating	Gear Ratio	Tracking Precision	Weight
类型	输出转矩	倾覆力矩	保持力矩	轴向静载荷	径向静载荷	轴向动载荷	径向动载荷	减速比	精度等级	重量
SEB7	1500 N.m 1107 lbf.ft	13500 N.m 9957 lbf.ft	10400 N.m 7671 lbf.ft	133 kN 29900 lbf	53 kN 11915 lbf	32 kN 7194 lbf	28 kN 6295 lbf	73 : 1	≤ 0.2°	26 kg
PEB7	1500 N.m 1107 lbf.ft	13500 N.m 9957 lbf.ft	10400 N.m 7671 lbf.ft	133 kN 29900 lbf	53 kN 11915 lbf	32 kN 7194 lbf	28 kN 6295 lbf	73 : 1	≤ 0.11°	26 kg

"A" VIEW AS INPUT IS ALLOWED
输入端允许在 "A" 向视图

SPECIAL DESIGN BASE ON CUSTOMER'S REQUIREMENT
可根据顾客的要求进行非标设计

NOTICE
Please be sure to remain under the curve. 选型时请确保实际载荷在曲线范围内。
This drawing is just for your reference. 以上图纸仅供参考。
This drawing is subject to change due to new design without prior notice. 本公司保留改进产品的权利而不再另行通知。
Please contact the technical department for dimensions and performance parameters of the drives. 如果需要装置的外形尺寸和性能参数, 请与技术部门联系。

SEB9/PEB9

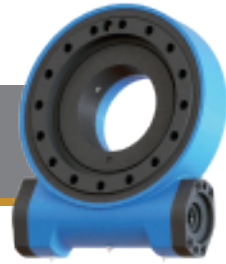

UNITS/单位:mm
1inch=25.4mm
Weight:49kg

FRONT VIEW
正视图

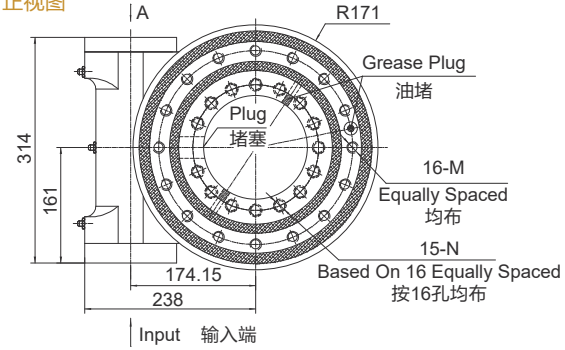

INPUT 输入端视图

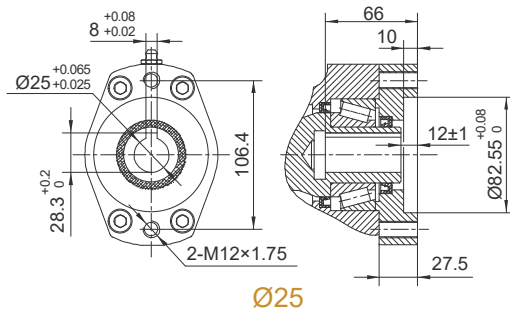

SIDE VIEW
侧视图

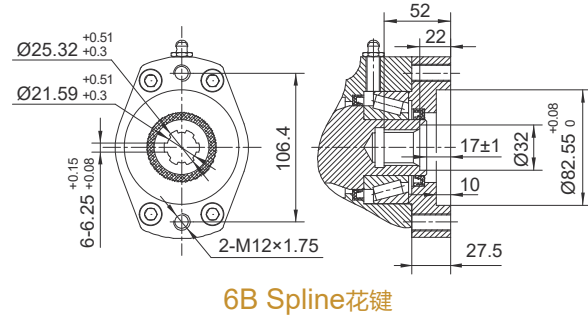
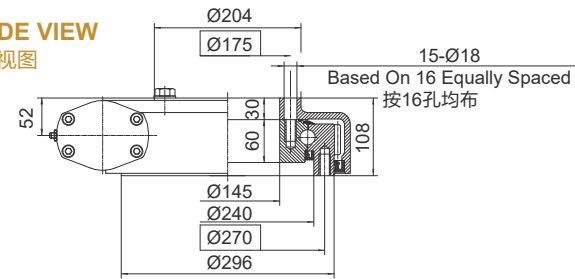

承载力矩图 MOMENT LOAD CHART

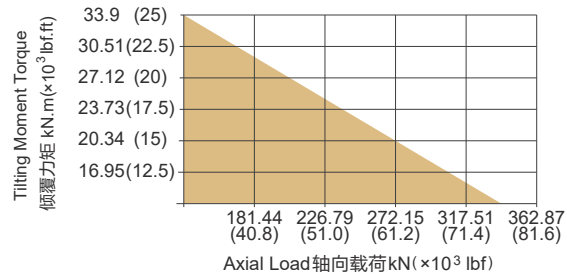

安装孔选项 Mounting Holes Option

Code 代码	M (Outer Ring 外圈)	N (Inner Ring 内圈)
—	M16×2 Tap (攻深)30	M16×2 Tap (攻深)30
T	M16×2 Tap (攻深)30	Ø18 Thru (通孔)
B	5/8"-11UNC-2B Tap (攻深)30	5/8"-11UNC-2B Tap (攻深)30
BT	5/8"-11UNC-2B Tap (攻深)30	Ø18 Thru (通孔)

性能参数表 Slewing Drive Performance Parameters

Model	Output Torque	Tilting Moment Torque	Holding Torque	Static Axial Rating	Static Radial Rating	Dynamic Axial Rating	Dynamic Radial Rating	Gear Ratio	Tracking Precision	Weight
类型	输出转矩	倾覆力矩	保持力矩	轴向静载荷	径向静载荷	轴向动载荷	径向动载荷	减速比	精度等级	重量
SEB9	6.5 kN.m 4794 lbf.ft	33.9 kN.m 25×10³ lbf.ft	34.5 kN.m 25.5×10³ lbf.ft	338 kN 76×10³ lbf	135 kN 30×10³ lbf	81 kN 18×10³ lbf	71 kN 16×10³ lbf	61 : 1	≤ 0.17°	49 kg
PEB9	6.5 kN.m 4794 lbf.ft	33.9 kN.m 25×10³ lbf.ft	34.5 kN.m 25.5×10³ lbf.ft	338 kN 76×10³ lbf	135 kN 30×10³ lbf	81 kN 18×10³ lbf	71 kN 16×10³ lbf	61 : 1	≤ 0.09°	49 kg

"A" VIEW AS INPUT IS ALLOWED
输入端允许在 "A" 向视图

SPECIAL DESIGN BASE ON CUSTOMER'S REQUIREMENT
可根据顾客的要求进行非标设计

NOTICE
Please be sure to remain under the curve. 选型时请确保实际载荷在曲线范围内。
This drawing is just for your reference. 以上图纸仅供参考。
This drawing is subject to change due to new design without prior notice. 本公司保留改进产品的权利而不再另行通知。
Please contact the technical department for dimensions and performance parameters of the drives. 如果需要装置的外形尺寸和性能参数, 请与技术部门联系。

SEB12/PEB12

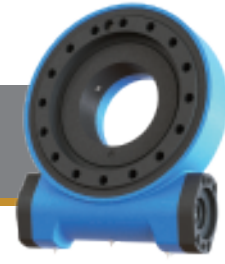

UNITS/单位:mm
1inch=25.4mm
Weight:68kg

FRONT VIEW
正视图

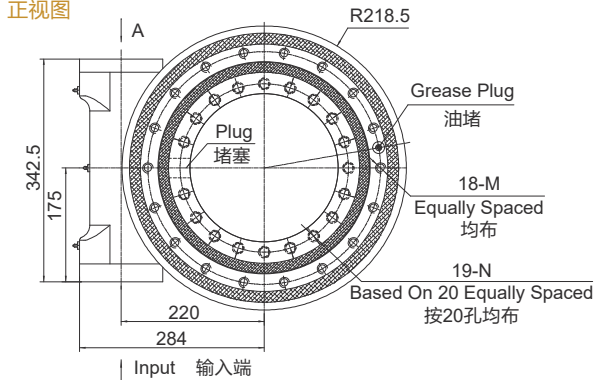

INPUT 输入端视图

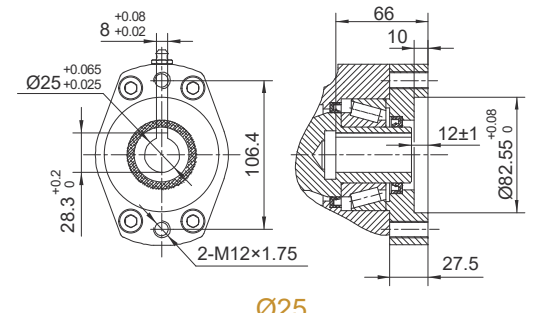

SIDE VIEW
侧视图

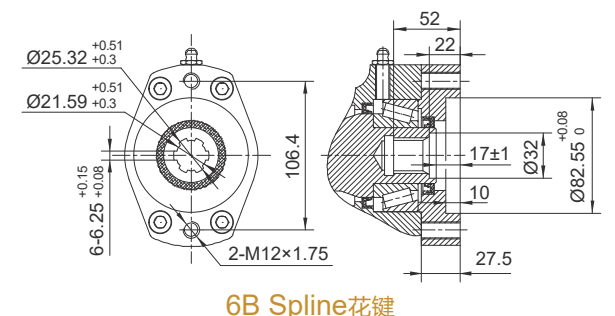
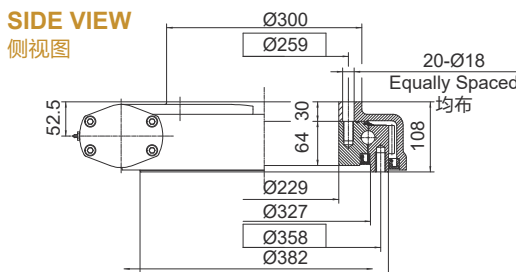

承载力矩图 MOMENT LOAD CHART

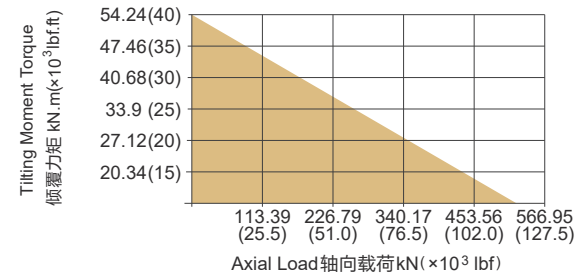

安装孔选项 Mounting Holes Option

Code 代码	M (Outer Ring 外圈)	N (Inner Ring 内圈)
—	M16×2 Tap (攻深)30	M16×2 Tap (攻深)30
T	M16×2 Tap (攻深)30	Ø18 Thru (通孔)
B	5/8"-11UNC-2B Tap (攻深)30	5/8"-11UNC-2B Tap (攻深)30
BT	5/8"-11UNC-2B Tap (攻深)30	Ø18 Thru (通孔)

性能参数表 Slewing Drive Performance Parameters

Model	Output Torque	Tilting Moment Torque	Holding Torque	Static Axial Rating	Static Radial Rating	Dynamic Axial Rating	Dynamic Radial Rating	Gear Ratio	Tracking Precision	Weight
类型	输出转矩	倾覆力矩	保持力矩	轴向静载荷	径向静载荷	轴向动载荷	径向动载荷	减速比	精度等级	重量
SEB12	7.5 kN.m 5532 lbf.ft	54.3 kN.m 40×10³ lbf.ft	43 kN.m 32×10³ lbf.ft	475 kN 107×10³ lbf	190 kN 43×10³ lbf	114 kN 26×10³ lbf	100 kN 23×10³ lbf	78 : 1	≤ 0.17°	68 kg
PEB12	7.5 kN.m 5532 lbf.ft	54.3 kN.m 40×10³ lbf.ft	43 kN.m 32×10³ lbf.ft	475 kN 107×10³ lbf	190 kN 43×10³ lbf	114 kN 26×10³ lbf	100 kN 23×10³ lbf	78 : 1	≤ 0.07°	68 kg

"A" VIEW AS INPUT IS ALLOWED
输入端允许在 "A" 向视图

SPECIAL DESIGN BASE ON CUSTOMER'S REQUIREMENT
可根据顾客的要求进行非标设计

NOTICE
Please be sure to remain under the curve. 选型时请确保实际载荷在曲线范围内。
This drawing is just for your reference. 以上图纸仅供参考。
This drawing is subject to change due to new design without prior notice. 本公司保留改进产品的权利而不再另行通知。
Please contact the technical department for dimensions and performance parameters of the drives. 如果需要装置的外形尺寸和性能参数, 请与技术部门联系。

SEB14/PEB14



UNITS/单位:mm
1inch=25.4mm
Weight:74kg

FRONT VIEW
正视图

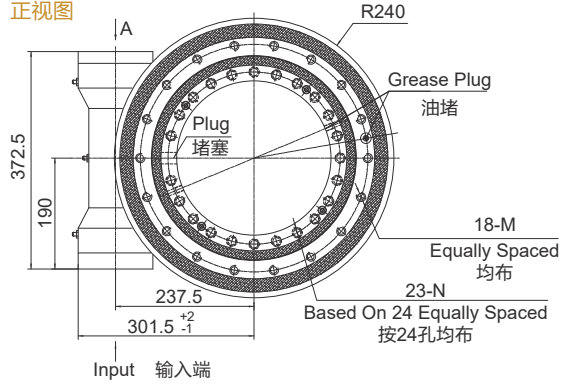

INPUT 输入端视图

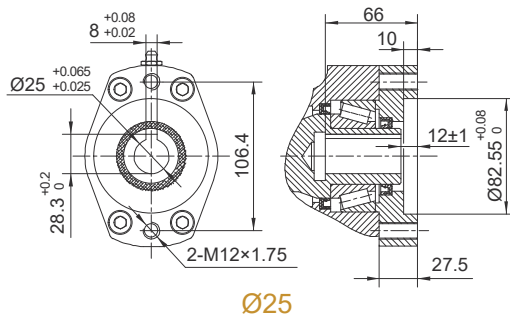

SIDE VIEW
侧视图

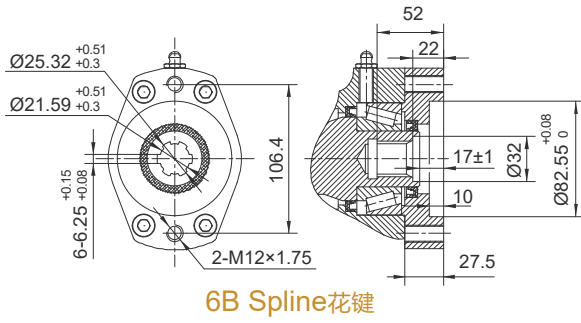
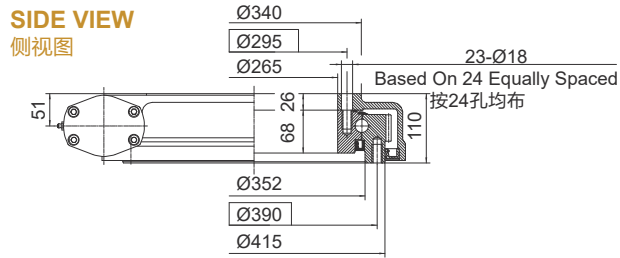

承载力矩图 MOMENT LOAD CHART

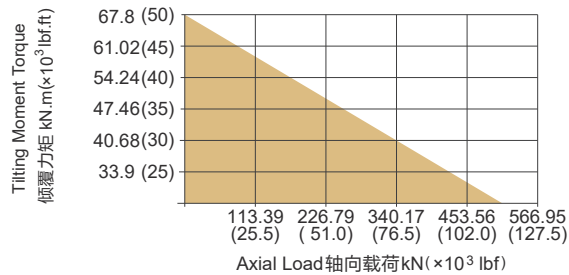

安装孔选项 Mounting Holes Option

Code 代码	M (Outer Ring 外圈)	N (Inner Ring 内圈)
—	M16×2 Tap (攻深)30	M16×2 Tap (攻深)30
T	M16×2 Tap (攻深)30	Ø18 Thru (通孔)
B	5/8"-11UNC-2B Tap (攻深)30	5/8"-11UNC-2B Tap (攻深)30
BT	5/8"-11UNC-2B Tap (攻深)30	Ø18 Thru (通孔)

性能参数表 Slewing Drive Performance Parameters

Model	Output Torque	Tilting Moment Torque	Holding Torque	Static Axial Rating	Static Radial Rating	Dynamic Axial Rating	Dynamic Radial Rating	Gear Ratio	Tracking Precision	Weight
SEB14	8 kN.m 5900 lbf.ft	67.8 kN.m 50×10 ³ lbf.ft	48 kN.m 35×10 ³ lbf.ft	555 kN 125×10 ³ lbf	222 kN 50×10 ³ lbf	133 kN 30×10 ³ lbf	117 kN 26×10 ³ lbf	85 : 1	≤ 0.17°	74 kg
PEB14	8 kN.m 5900 lbf.ft	67.8 kN.m 50×10 ³ lbf.ft	48 kN.m 35×10 ³ lbf.ft	555 kN 125×10 ³ lbf	222 kN 50×10 ³ lbf	133 kN 30×10 ³ lbf	117 kN 26×10 ³ lbf	85 : 1	≤ 0.09°	74 kg

SEB17C/PEB17C



UNITS/单位:mm
1inch=25.4mm
Weight:92kg

FRONT VIEW
正视图

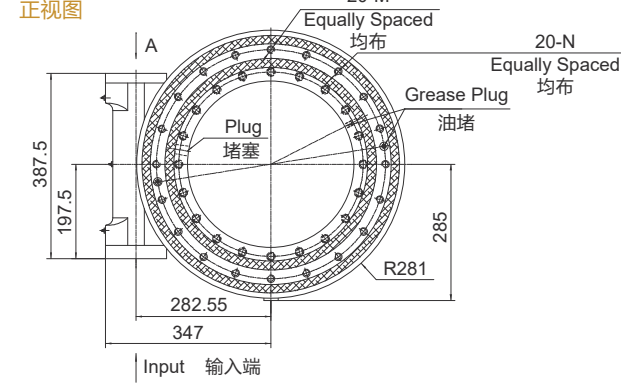

INPUT 输入端视图

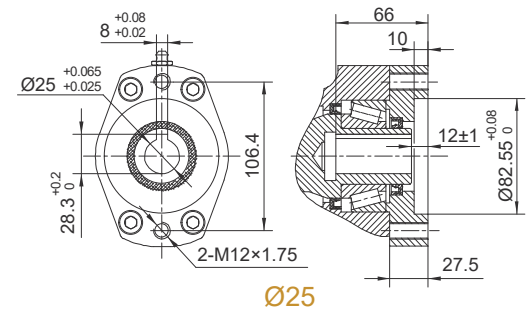

SIDE VIEW
侧视图

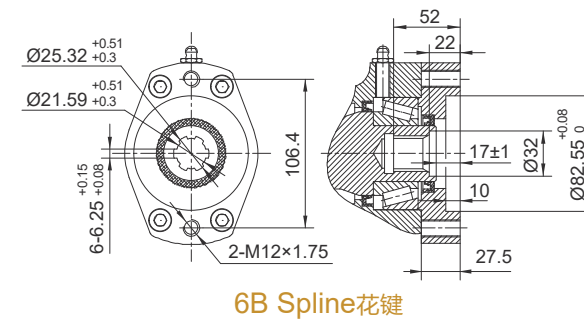
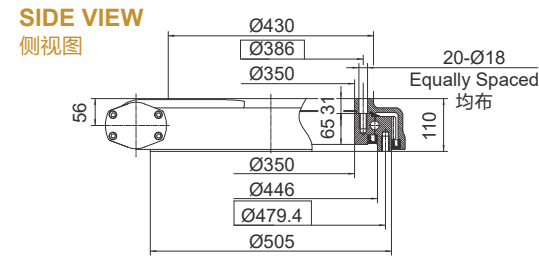

承载力矩图 MOMENT LOAD CHART

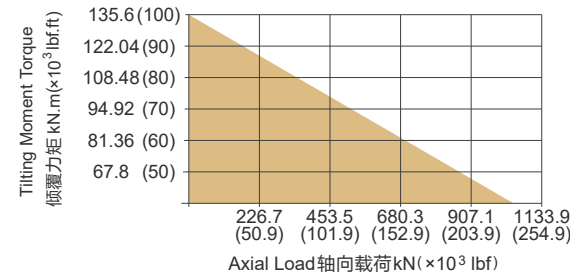

安装孔选项 Mounting Holes Option

Code 代码	M (Outer Ring 外圈)	N (Inner Ring 内圈)
—	M16×2 Tap (攻深)32	M16×2 Tap (攻深)32
T	M16×2 Tap (攻深)32	Ø18 Thru (通孔)
B	5/8"-11UNC-2B Tap (攻深)32	5/8"-11UNC-2B Tap (攻深)32
BT	5/8"-11UNC-2B Tap (攻深)32	Ø18 Thru (通孔)

性能参数表 Slewing Drive Performance Parameters

Model	Output Torque	Tilting Moment Torque	Holding Torque	Static Axial Rating	Static Radial Rating	Dynamic Axial Rating	Dynamic Radial Rating	Gear Ratio	Tracking Precision	Weight
SEB17C	10 kN.m 7400 lbf.ft	135.6 kN.m 100×10 ³ lbf.ft	58 kN.m 42.8×10 ³ lbf.ft	970 kN 218×10 ³ lbf	390 kN 88×10 ³ lbf	235 kN 53×10 ³ lbf	205 kN 46×10 ³ lbf	102 : 1	≤ 0.15°	92 kg
PEB17C	10 kN.m 7400 lbf.ft	135.6 kN.m 100×10 ³ lbf.ft	58 kN.m 42.8×10 ³ lbf.ft	970 kN 218×10 ³ lbf	390 kN 88×10 ³ lbf	235 kN 53×10 ³ lbf	205 kN 46×10 ³ lbf	102 : 1	≤ 0.09°	92 kg

SEB21/PEB21



UNITS/单位:mm
1inch=25.4mm
Weight:142kg

FRONT VIEW
正视图

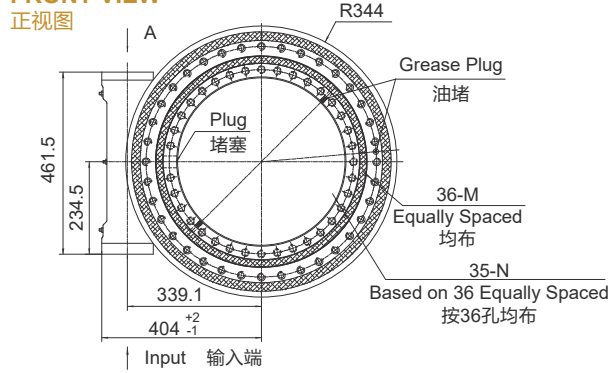

INPUT 输入端视图

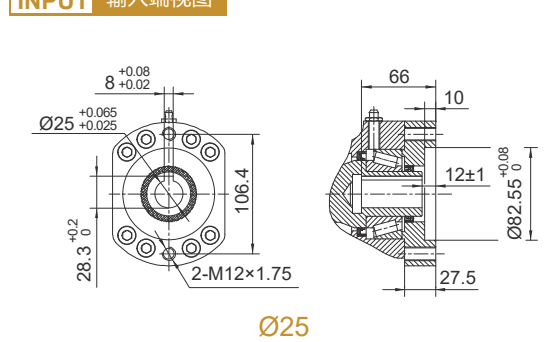

SIDE VIEW
侧视图

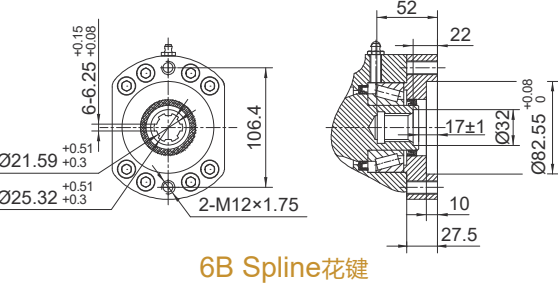
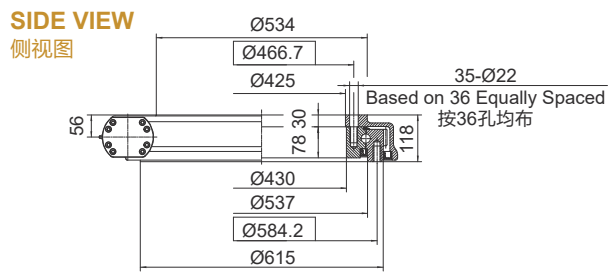

承载力矩图 MOMENT LOAD CHART

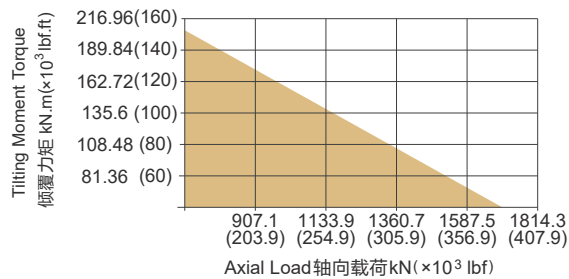

安装孔选项 Mounting Holes Option

Code 代码	M (Outer Ring 外圈)	N (Inner Ring 内圈)
—	M20×2.5 Tap (攻深)40	M20×2.5 Tap (攻深)40
T	M20×2.5 Tap (攻深)40	Ø22 Thru (通孔)
B	3/4"-10UNC-2B Tap (攻深)40	3/4"-10UNC-2B Tap (攻深)40
BT	3/4"-10UNC-2B Tap (攻深)40	Ø22 Thru (通孔)

性能参数表 Slewing Drive Performance Parameters

Model	Output Torque	Tilting Moment Torque	Holding Torque	Static Axial Rating	Static Radial Rating	Dynamic Axial Rating	Dynamic Radial Rating	Gear Ratio	Tracking Precision	Weight
SEB21	15 kN.m 11000 lbf.ft	203 kN.m 150×10³ lbf.ft	70.5 kN.m 52×10³ lbf.ft	1598 kN 359×10³ lbf	640 kN 144×10³ lbf	385 kN 87×10³ lbf	335 kN 75×10³ lbf	125 : 1	≤ 0.15°	142 kg
PEB21	15 kN.m 11000 lbf.ft	203 kN.m 150×10³ lbf.ft	70.5 kN.m 52×10³ lbf.ft	1598 kN 359×10³ lbf	640 kN 144×10³ lbf	385 kN 87×10³ lbf	335 kN 75×10³ lbf	125 : 1	≤ 0.09°	142 kg

"A" VIEW AS INPUT IS ALLOWED
输入端允许在 "A" 向视图

SPECIAL DESIGN BASE ON CUSTOMER'S REQUIREMENT
可根据顾客的要求进行非标设计

NOTICE 注意
• Please be sure to remain under the curve. 选型时请确保实际载荷在曲线范围内。
• This drawing is just for your reference. 以上图纸仅供参考。
• This drawing is subject to change due to new design without prior notice. 本公司保留改进产品的权利而不再另行通知。
• Please contact the technical department for dimensions and performance parameters of the drives. 如果需要装置的外形尺寸和性能参数, 请与技术部门联系。

SEB25/PEB25



UNITS/单位:mm
1inch=25.4mm
Weight:168kg

FRONT VIEW
正视图

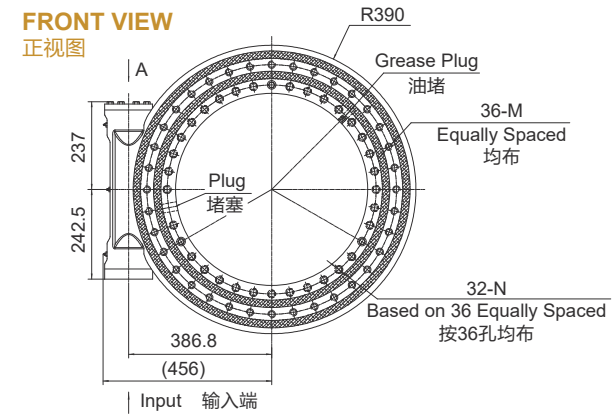

INPUT 输入端视图

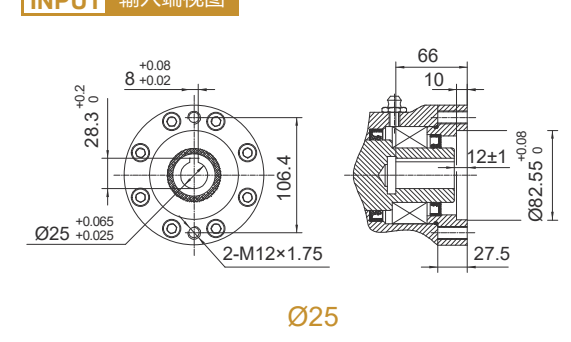

SIDE VIEW
侧视图

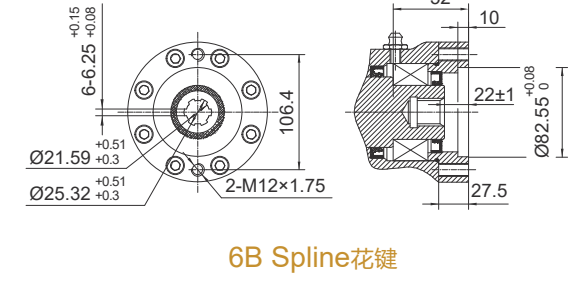
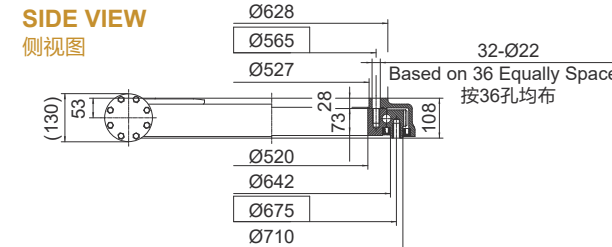

承载力矩图 MOMENT LOAD CHART

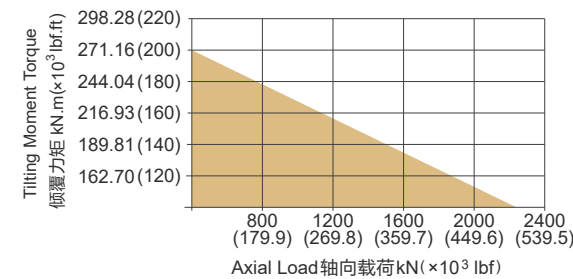

安装孔选项 Mounting Holes Option

Code 代码	M (Outer Ring 外圈)	N (Inner Ring 内圈)
—	M20×2.5 Tap (攻深)40	M20×2.5 Tap (攻深)40
T	M20×2.5 Tap (攻深)40	Ø22 Thru (通孔)
B	3/4"-10UNC-2B Tap (攻深)40	3/4"-10UNC-2B Tap (攻深)40
BT	3/4"-10UNC-2B Tap (攻深)40	Ø22 Thru (通孔)

性能参数表 Slewing Drive Performance Parameters

Model	Output Torque	Tilting Moment Torque	Holding Torque	Static Axial Rating	Static Radial Rating	Dynamic Axial Rating	Dynamic Radial Rating	Gear Ratio	Tracking Precision	Weight
SEB25	18 kN.m 13300 lbf.ft	271 kN.m 200×10³ lbf.ft	84.5 kN.m 62.4×10³ lbf.ft	2360 kN 531×10³ lbf	945 kN 212×10³ lbf	590 kN 133×10³ lbf	470 kN 106×10³ lbf	150 : 1	≤ 0.15°	168 kg
PEB25	18 kN.m 13300 lbf.ft	271 kN.m 200×10³ lbf.ft	84.5 kN.m 117×10³ lbf.ft	2360 kN 531×10³ lbf	945 kN 212×10³ lbf	590 kN 133×10³ lbf	470 kN 106×10³ lbf	150 : 1	≤ 0.09°	168 kg

"A" VIEW AS INPUT IS ALLOWED
输入端允许在 "A" 向视图

SPECIAL DESIGN BASE ON CUSTOMER'S REQUIREMENT
可根据顾客的要求进行非标设计

NOTICE 注意
• Please be sure to remain under the curve. 选型时请确保实际载荷在曲线范围内。
• This drawing is just for your reference. 以上图纸仅供参考。
• This drawing is subject to change due to new design without prior notice. 本公司保留改进产品的权利而不再另行通知。
• Please contact the technical department for dimensions and performance parameters of the drives. 如果需要装置的外形尺寸和性能参数, 请与技术部门联系。

HSE7



UNITS/单位:mm
1inch=25.4mm
Weight:37.5kg

FRONT VIEW
正视图

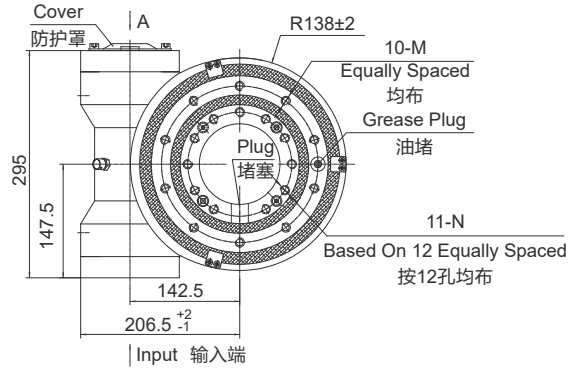

INPUT 输入端视图

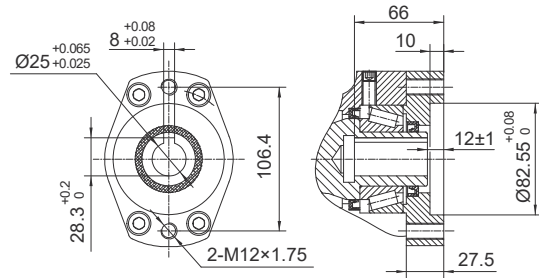

SIDE VIEW
侧视图

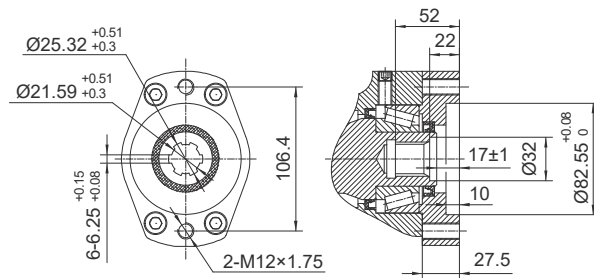
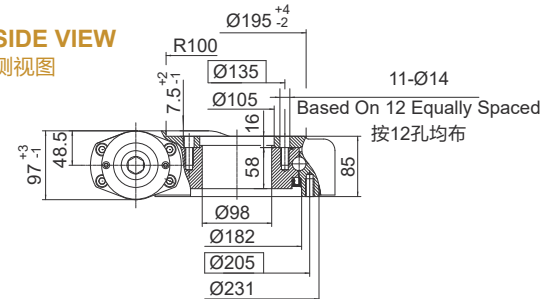

6B Spline花键

承载力矩图 MOMENT LOAD CHART

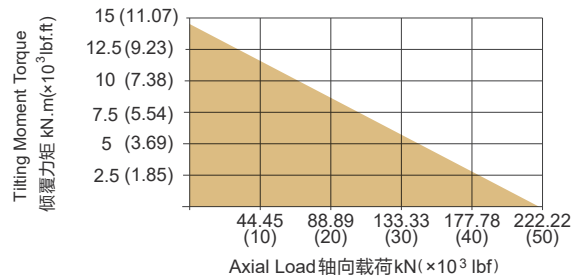

安装孔选项 Mounting Holes Option

Code 代码	M (Outer Ring 外圈)	N (Inner Ring 内圈)
—	M12×1.75 Tap (攻深)25	M12×1.75 Tap (攻深)25
T	M12×1.75 Tap (攻深)25	Ø14 Thru (通孔)
B	1/2"-13UNC-2B Tap (攻深)25	1/2"-13UNC-2B Tap (攻深)25
BT	1/2"-13UNC-2B Tap (攻深)25	Ø14 Thru (通孔)

性能参数表 Slewing Drive Performance Parameters

Output Torque	Tilting Moment Torque	Holding Torque	Static Axial Rating	Static Radial Rating	Dynamic Axial Rating	Dynamic Radial Rating	Gear Ratio	Tracking Precision	Weight
输出转矩	倾覆力矩	保持力矩	轴向静载荷	径向静载荷	轴向动载荷	径向动载荷	减速比	精度等级	重量
3.5 kN.m	14.2 kN.m	20 kN.m	220 kN	90 kN	63 kN	48 kN	47 : 1	≤ 0.15°	37.5 kg
2583 lbf.ft	10.5×10 ³ lbf.ft	14.8×10 ³ lbf.ft	49.5×10 ³ lbf	20.2×10 ³ lbf	14.2×10 ³ lbf	10.8×10 ³ lbf			

"A" VIEW AS INPUT IS ALLOWED
输入端允许在 "A" 向视图

SPECIAL DESIGN BASE ON CUSTOMER'S REQUIREMENT
可根据顾客的要求进行非标设计

- NOTICE**
- Please be sure to remain under the curve. 选型时请确保实际载荷在曲线范围内。
 - This drawing is just for your reference. 以上图纸仅供参考。
 - This drawing is subject to change due to new design without prior notice. 本公司保留改进产品的权利而不再另行通知。
 - Please contact the technical department for dimensions and performance parameters of the drives. 如果需要装置的外形尺寸和性能参数, 请与技术部门联系。

HSE9



UNITS/单位:mm
1inch=25.4mm
Weight:55.5kg

FRONT VIEW
正视图

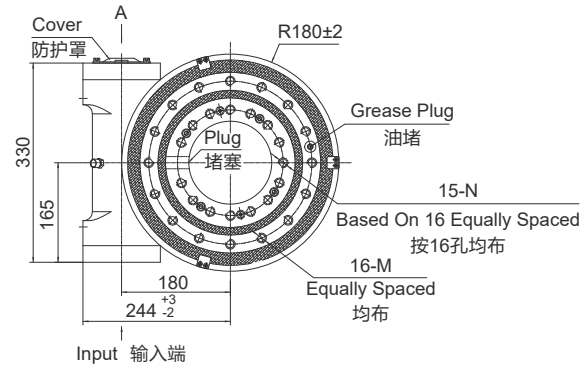

INPUT 输入端视图

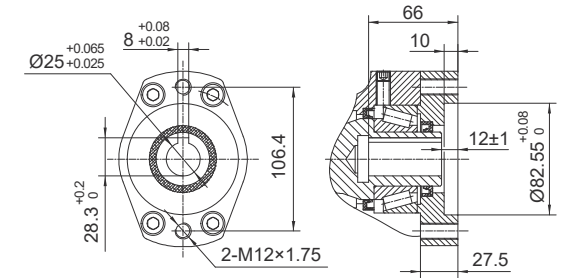

SIDE VIEW
侧视图

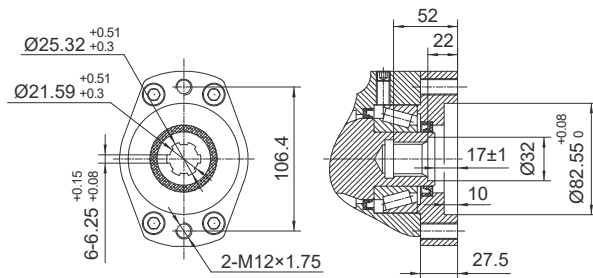
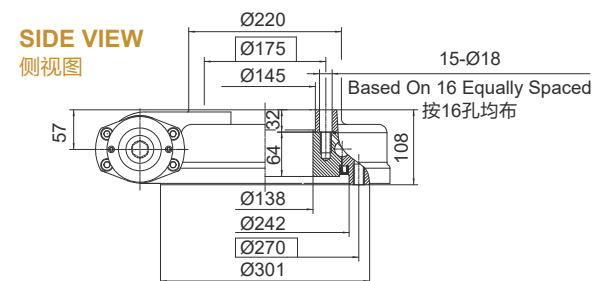

6B Spline花键

承载力矩图 MOMENT LOAD CHART

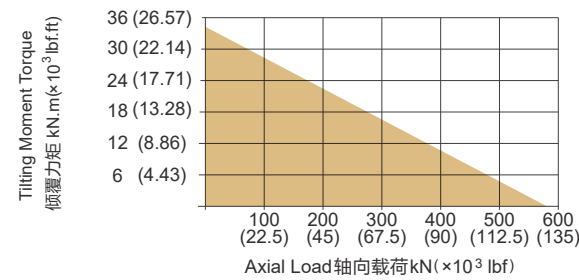

安装孔选项 Mounting Holes Option

Code 代码	M (Outer Ring 外圈)	N (Inner Ring 内圈)
—	M16×2 Tap (攻深)30	M16×2 Tap (攻深)30
T	M16×2 Tap (攻深)30	Ø18 Thru (通孔)
B	5/8"-11UNC-2B Tap (攻深)30	5/8"-11UNC-2B Tap (攻深)30
BT	5/8"-11UNC-2B Tap (攻深)30	Ø18 Thru (通孔)

性能参数表 Slewing Drive Performance Parameters

Output Torque	Tilting Moment Torque	Holding Torque	Static Axial Rating	Static Radial Rating	Dynamic Axial Rating	Dynamic Radial Rating	Gear Ratio	Tracking Precision	Weight
输出转矩	倾覆力矩	保持力矩	轴向静载荷	径向静载荷	轴向动载荷	径向动载荷	减速比	精度等级	重量
8 kN.m	35.6 kN.m	34.5 kN.m	578 kN	215 kN	136 kN	115 kN	62 : 1	≤ 0.15°	55.5 kg
5904 lbf.ft	26.3×10 ³ lbf.ft	25.5×10 ³ lbf.ft	129.9×10 ³ lbf	48.3×10 ³ lbf	30.6×10 ³ lbf	25.9×10 ³ lbf			

"A" VIEW AS INPUT IS ALLOWED
输入端允许在 "A" 向视图

SPECIAL DESIGN BASE ON CUSTOMER'S REQUIREMENT
可根据顾客的要求进行非标设计

- NOTICE**
- Please be sure to remain under the curve. 选型时请确保实际载荷在曲线范围内。
 - This drawing is just for your reference. 以上图纸仅供参考。
 - This drawing is subject to change due to new design without prior notice. 本公司保留改进产品的权利而不再另行通知。
 - Please contact the technical department for dimensions and performance parameters of the drives. 如果需要装置的外形尺寸和性能参数, 请与技术部门联系。

HSE12



UNITS/单位:mm
1inch=25.4mm
Weight:74kg

FRONT VIEW
正视图

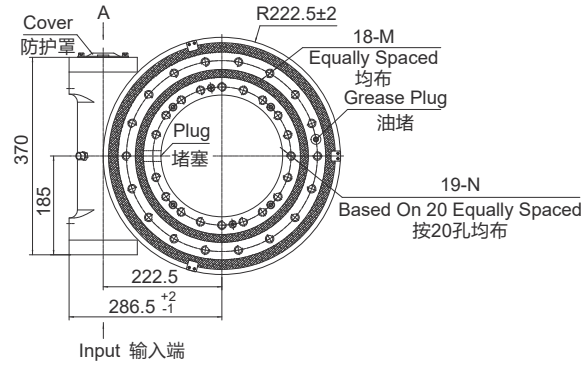

INPUT 输入端视图

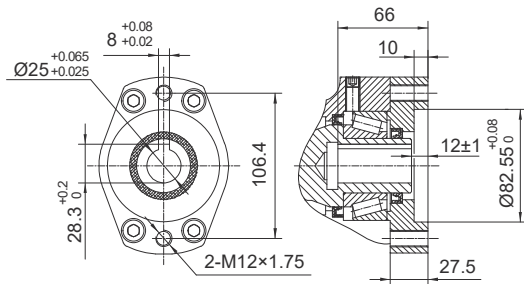

SIDE VIEW
侧视图

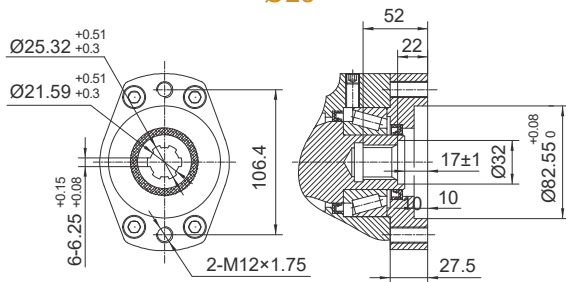
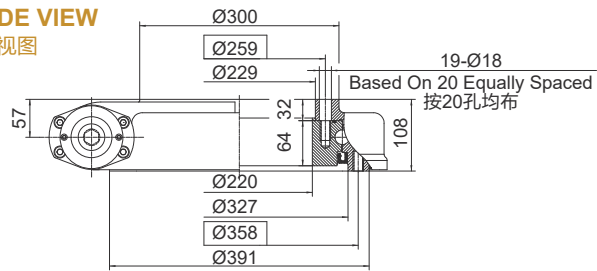

承载力矩图 MOMENT LOAD CHART

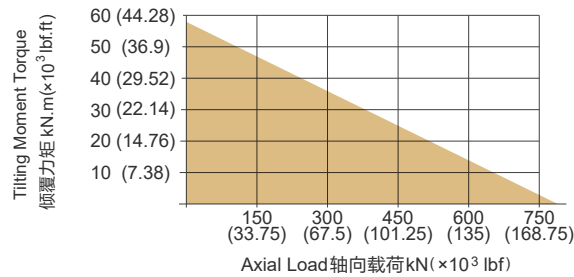

安装孔选项 Mounting Holes Option

Code 代码	M (Outer Ring 外圈)	N (Inner Ring 内圈)
—	M16×2 Tap (攻深)30	M16×2 Tap (攻深)30
T	M16×2 Tap (攻深)30	Ø18 Thru (通孔)
B	5/8"-11UNC-2B Tap (攻深)30	5/8"-11UNC-2B Tap (攻深)30
BT	5/8"-11UNC-2B Tap (攻深)30	Ø18 Thru (通孔)

性能参数表 Slewing Drive Performance Parameters

Output Torque	Tilting Moment Torque	Holding Torque	Static Axial Rating	Static Radial Rating	Dynamic Axial Rating	Dynamic Radial Rating	Gear Ratio	Tracking Precision	Weight
9.5 kN.m	57 kN.m	43 kN.m	760 kN	280 kN	190 kN	148 kN	79 : 1	≤ 0.15°	74 kg
7011 lbf.ft	42.1×10 ³ lbf.ft	32×10 ³ lbf.ft	171.1×10 ³ lbf	62.9×10 ³ lbf	42.7×10 ³ lbf	33.3×10 ³ lbf			

"A" VIEW AS INPUT IS ALLOWED
输入端允许在 "A" 向视图

SPECIAL DESIGN BASE ON CUSTOMER'S REQUIREMENT
可根据顾客的要求进行非标设计

- NOTICE 注意**
- Please be sure to remain under the curve. 选型时请确保实际载荷在曲线范围内。
 - This drawing is just for your reference. 以上图纸仅供参考。
 - This drawing is subject to change due to new design without prior notice. 本公司保留改进产品的权利而不再另行通知。
 - Please contact the technical department for dimensions and performance parameters of the drives. 如果需要装置的外形尺寸和性能参数, 请与技术部门联系。

HSE14



UNITS/单位:mm
1inch=25.4mm
Weight:82kg

FRONT VIEW
正视图

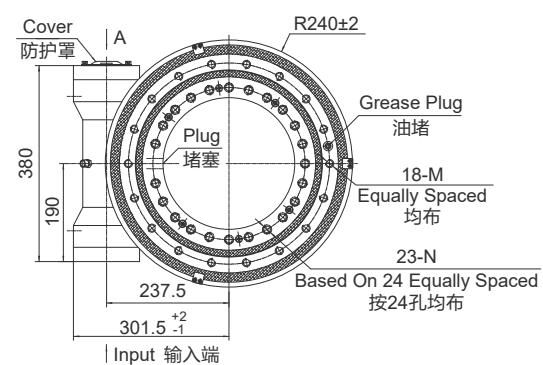

INPUT 输入端视图

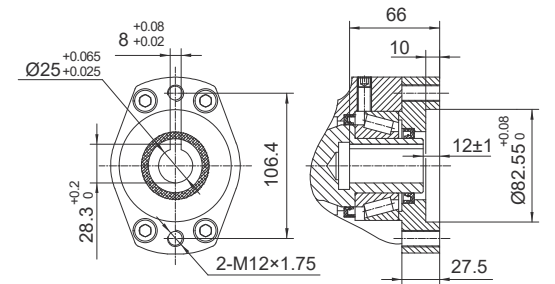

SIDE VIEW
侧视图

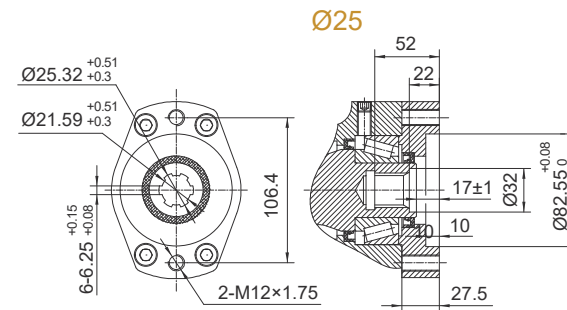
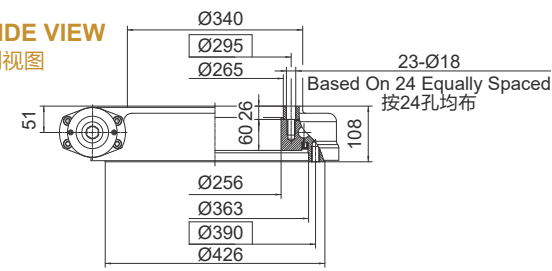

承载力矩图 MOMENT LOAD CHART

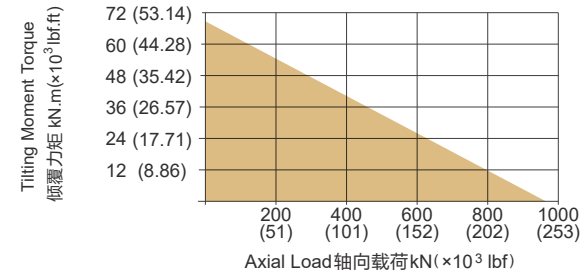

安装孔选项 Mounting Holes Option

Code 代码	M (Outer Ring 外圈)	N (Inner Ring 内圈)
—	M16×2 Tap (攻深)30	M16×2 Tap (攻深)30
T	M16×2 Tap (攻深)30	Ø18 Thru (通孔)
B	5/8"-11UNC-2B Tap (攻深)30	5/8"-11UNC-2B Tap (攻深)30
BT	5/8"-11UNC-2B Tap (攻深)30	Ø18 Thru (通孔)

性能参数表 Slewing Drive Performance Parameters

Output Torque	Tilting Moment Torque	Holding Torque	Static Axial Rating	Static Radial Rating	Dynamic Axial Rating	Dynamic Radial Rating	Gear Ratio	Tracking Precision	Weight
10.8kN.m	71.2kN.m	48 kN.m	960 kN	360 kN	230 kN	200 kN	86 : 1	≤ 0.13°	82kg
7970 lbf.ft	52.6×10 ³ lbf.ft	35×10 ³ lbf.ft	215.8×10 ³ lbf	80.9×10 ³ lbf	51.7×10 ³ lbf	44.9×10 ³ lbf			

"A" VIEW AS INPUT IS ALLOWED
输入端允许在 "A" 向视图

SPECIAL DESIGN BASE ON CUSTOMER'S REQUIREMENT
可根据顾客的要求进行非标设计

- NOTICE 注意**
- Please be sure to remain under the curve. 选型时请确保实际载荷在曲线范围内。
 - This drawing is just for your reference. 以上图纸仅供参考。
 - This drawing is subject to change due to new design without prior notice. 本公司保留改进产品的权利而不再另行通知。
 - Please contact the technical department for dimensions and performance parameters of the drives. 如果需要装置的外形尺寸和性能参数, 请与技术部门联系。

HSE17



UNITS/单位:mm
1inch=25.4mm
Weight:108kg

FRONT VIEW
正视图

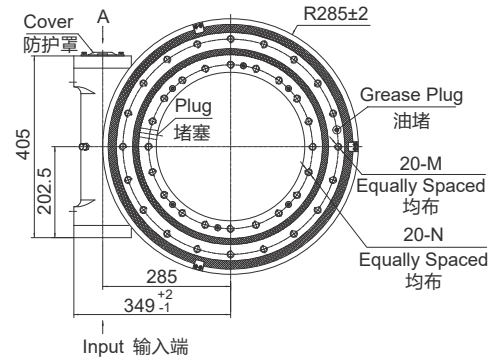

INPUT 输入端视图

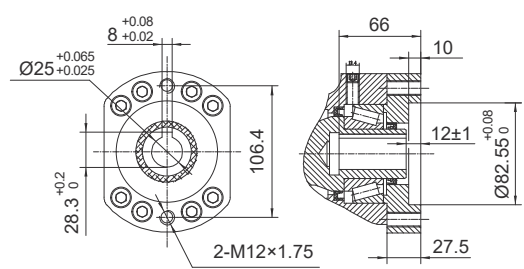

SIDE VIEW
侧视图

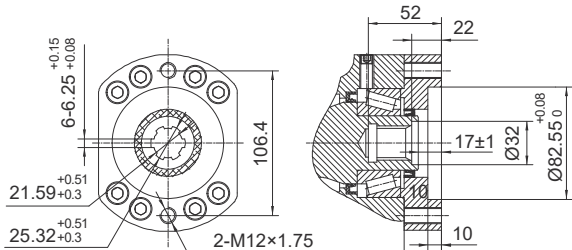
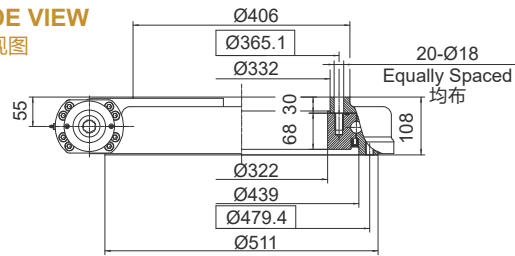

6B Spline花键

承载力矩图 MOMENT LOAD CHART

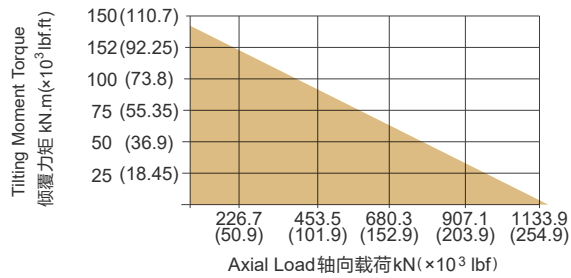

安装孔选项 Mounting Holes Option

Code 代码	M (Outer Ring 外圈)	N (Inner Ring 内圈)
—	M16×2 Tap (攻深)32	M16×2 Tap (攻深)32
T	M16×2 Tap (攻深)32	Ø18 Thru (通孔)
B	5/8"-11UNC-2B Tap (攻深)32	5/8"-11UNC-2B Tap (攻深)32
BT	5/8"-11UNC-2B Tap (攻深)32	Ø18 Thru (通孔)

性能参数表 Slewing Drive Performance Parameters

Output Torque	Tilting Moment Torque	Holding Torque	Static Axial Rating	Static Radial Rating	Dynamic Axial Rating	Dynamic Radial Rating	Gear Ratio	Tracking Precision	Weight
输出转矩	倾覆力矩	保持力矩	轴向静载荷	径向静载荷	轴向动载荷	径向动载荷	减速比	精度等级	重量
12.96 kN.m	142.4 kN.m	72.3 kN.m	1166 kN	435 kN	280 kN	231 kN	104 : 1	≤ 0.1°	108 kg
9564 lbf.ft	105.1×10³ lbf.ft	53.4×10³ lbf.ft	262×10³ lbf	97.8×10³ lbf	62.9×10³ lbf	51.9×10³ lbf			

"A" VIEW AS INPUT IS ALLOWED
输入端允许在 "A" 向视图

SPECIAL DESIGN BASE ON CUSTOMER'S REQUIREMENT
可根据顾客的要求进行非标设计

- NOTICE 注意
- Please be sure to remain under the curve. 选型时请确保实际载荷在曲线范围内。
 - This drawing is just for your reference. 以上图纸仅供参考。
 - This drawing is subject to change due to new design without prior notice. 本公司保留改进产品的权利而不再另行通知。
 - Please contact the technical department for dimensions and performance parameters of the drives. 如果需要装置的外形尺寸和性能参数, 请与技术部门联系。

HSE19

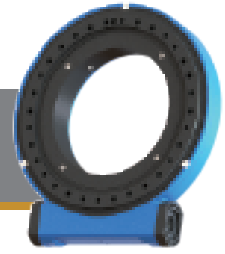

UNITS/单位:mm
1inch=25.4mm
Weight:122kg

FRONT VIEW
正视图

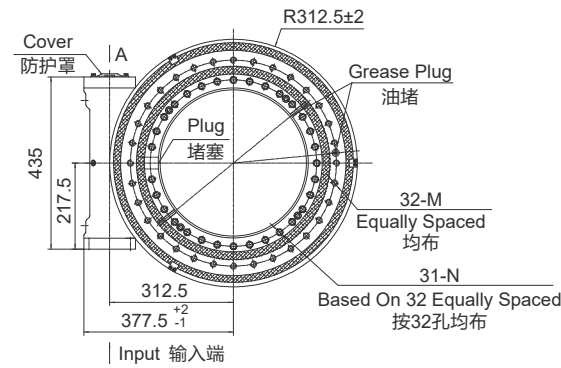

INPUT 输入端视图

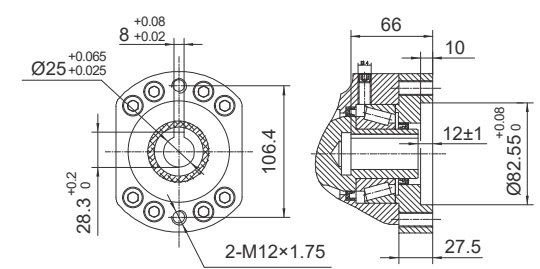

SIDE VIEW
侧视图

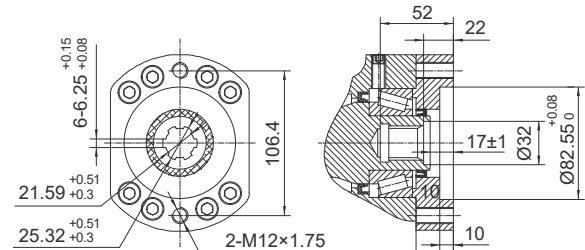
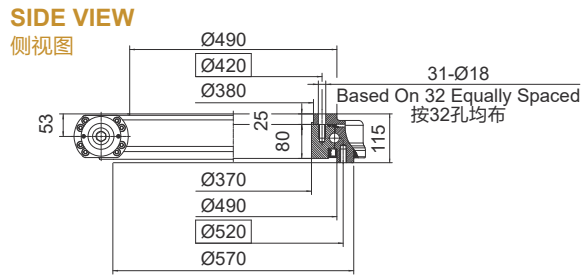

6B Spline花键

承载力矩图 MOMENT LOAD CHART

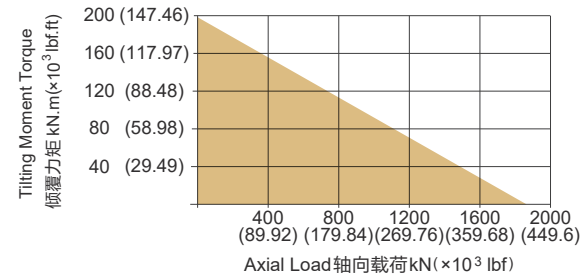

安装孔选项 Mounting Holes Option

Code 代码	M (Outer Ring 外圈)	N (Inner Ring 内圈)
—	M16×2 Tap (攻深)32	M16×2 Tap (攻深)32
T	M16×2 Tap (攻深)32	Ø18 Thru (通孔)
B	5/8"-11UNC-2B Tap (攻深)32	5/8"-11UNC-2B Tap (攻深)32
BT	5/8"-11UNC-2B Tap (攻深)32	Ø18 Thru (通孔)

性能参数表 Slewing Drive Performance Parameters

Output Torque	Tilting Moment Torque	Holding Torque	Static Axial Rating	Static Radial Rating	Dynamic Axial Rating	Dynamic Radial Rating	Gear Ratio	Tracking Precision	Weight
输出转矩	倾覆力矩	保持力矩	轴向静载荷	径向静载荷	轴向动载荷	径向动载荷	减速比	精度等级	重量
18.5 kN.m	196 kN.m	80.1 kN.m	1800 kN	675 kN	290 kN	250 kN	94 : 1	≤ 0.1°	122 kg
13640 lbf.ft	144.5×10³ lbf.ft	59.1×10³ lbf.ft	404.64×10³ lbf	151.4×10³ lbf	65.2×10³ lbf	56.2×10³ lbf			

"A" VIEW AS INPUT IS ALLOWED
输入端允许在 "A" 向视图

SPECIAL DESIGN BASE ON CUSTOMER'S REQUIREMENT
可根据顾客的要求进行非标设计

- NOTICE 注意
- Please be sure to remain under the curve. 选型时请确保实际载荷在曲线范围内。
 - This drawing is just for your reference. 以上图纸仅供参考。
 - This drawing is subject to change due to new design without prior notice. 本公司保留改进产品的权利而不再另行通知。
 - Please contact the technical department for dimensions and performance parameters of the drives. 如果需要装置的外形尺寸和性能参数, 请与技术部门联系。

HSE21A



UNITS/单位:mm
1inch=25.4mm
Weight:188kg

FRONT VIEW
正视图

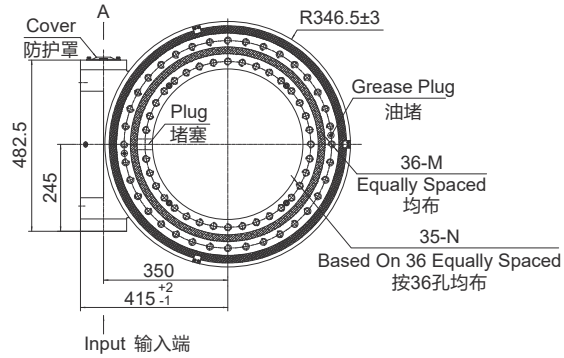

INPUT 输入端视图

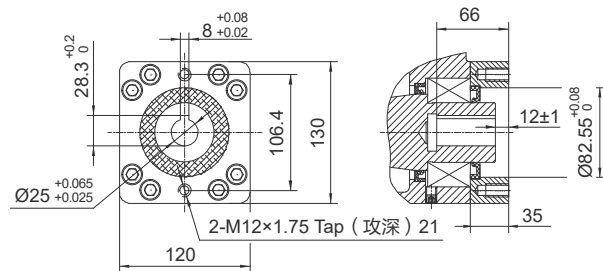

SIDE VIEW
侧视图

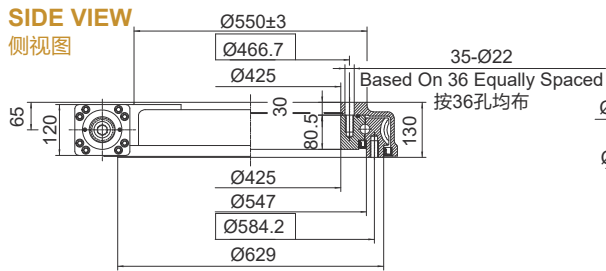

Ø25

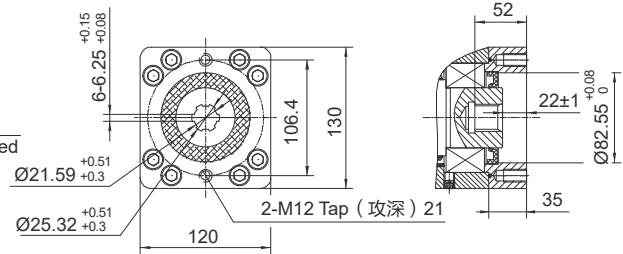

6B Spline花键

承载力矩图 MOMENT LOAD CHART

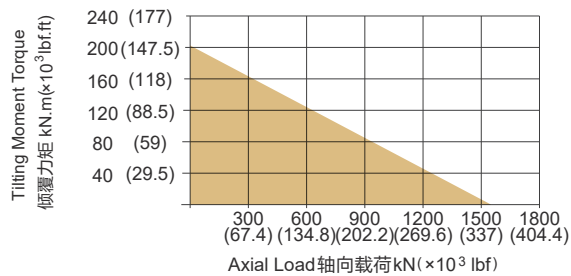

安装孔选项 Mounting Holes Option

Code 代码	M (Outer Ring 外圈)	N (Inner Ring 内圈)
—	M20×2.5 Tap (攻深)40	M20×2.5 Tap (攻深)40
T	M20×2.5 Tap (攻深)40	Ø22 Thru (通孔)
B	3/4"-10UNC-2B Tap (攻深)40	3/4"-10UNC-2B Tap (攻深)40
BT	3/4"-10UNC-2B Tap (攻深)40	Ø22 Thru (通孔)

性能参数表 Slewing Drive Performance Parameters

Output Torque	Tilting Moment Torque	Holding Torque	Static Axial Rating	Static Radial Rating	Dynamic Axial Rating	Dynamic Radial Rating	Gear Ratio	Tracking Precision	Weight
输出转矩	倾覆力矩	保持力矩	轴向静载荷	径向静载荷	轴向动载荷	径向动载荷	减速比	精度等级	重量
28.7 kN.m	203 kN.m	105.8 kN.m	1598 kN	640 kN	385 kN	335 kN	90 : 1	≤ 0.1°	188 kg
21180 lbf.ft	150×10 ³ lbf.ft	78.1×10 ³ lbf.ft	359×10 ³ lbf	144×10 ³ lbf	87×10 ³ lbf	75×10 ³ lbf			

"A" VIEW AS INPUT IS ALLOWED
输入端允许在“A”向视图

SPECIAL DESIGN BASE ON CUSTOMER'S REQUIREMENT
可根据顾客的要求进行非标设计

- NOTICE 注意**
- Please be sure to remain under the curve. 选型时请确保实际载荷在曲线范围内。
 - This drawing is just for your reference. 以上图纸仅供参考。
 - This drawing is subject to change due to new design without prior notice. 本公司保留改进产品的权利而不再另行通知。
 - Please contact the technical department for dimensions and performance parameters of the drives. 如果需要装置的外形尺寸和性能参数, 请与技术部门联系。

HSE21A-2

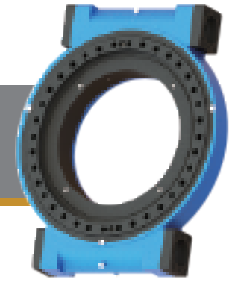

UNITS/单位:mm
1inch=25.4mm
Weight:205kg

FRONT VIEW
正视图

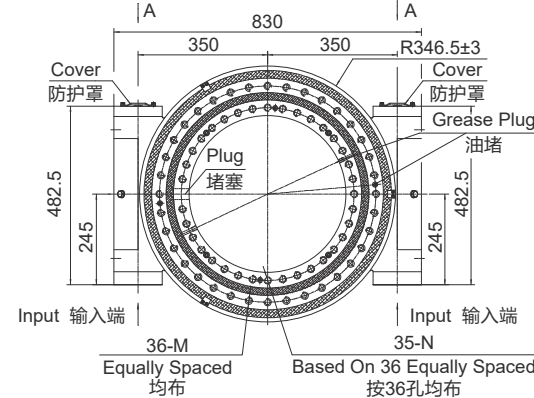

INPUT 输入端视图

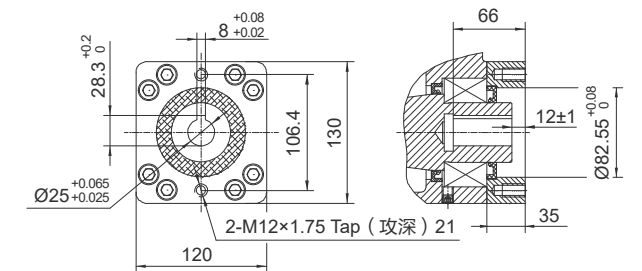

SIDE VIEW
侧视图

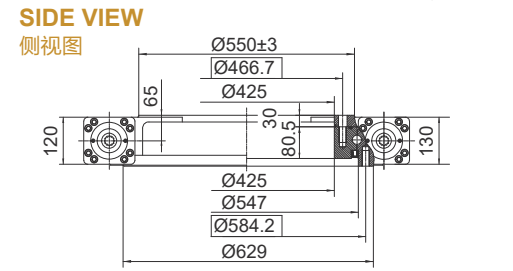

Ø25

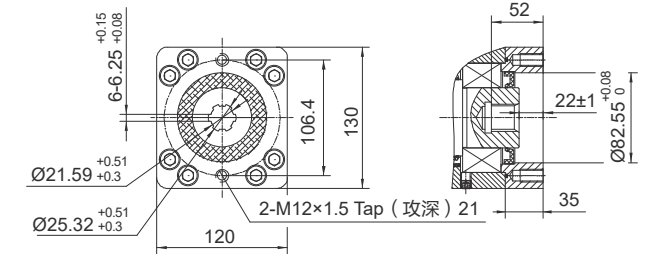

6B Spline花键

承载力矩图 MOMENT LOAD CHART

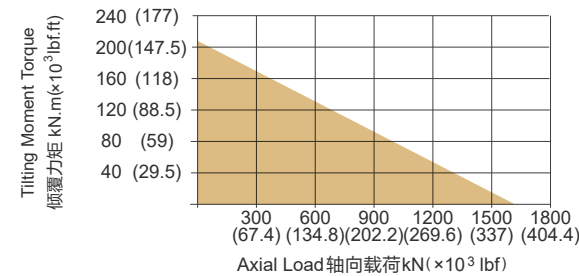

安装孔选项 Mounting Holes Option

Code 代码	M (Outer Ring 外圈)	N (Inner Ring 内圈)
—	M20×2.5 Tap (攻深)40	M20×2.5 Tap (攻深)40
T	M20×2.5 Tap (攻深)40	Ø22 Thru (通孔)
B	3/4"-10UNC-2B Tap (攻深)40	3/4"-10UNC-2B Tap (攻深)40
BT	3/4"-10UNC-2B Tap (攻深)40	Ø22 Thru (通孔)

性能参数表 Slewing Drive Performance Parameters

Output Torque	Tilting Moment Torque	Holding Torque	Static Axial Rating	Static Radial Rating	Dynamic Axial Rating	Dynamic Radial Rating	Gear Ratio	Tracking Precision	Weight
输出转矩	倾覆力矩	保持力矩	轴向静载荷	径向静载荷	轴向动载荷	径向动载荷	减速比	精度等级	重量
48 kN.m	203 kN.m	179.9 kN.m	1598 kN	640 kN	385 kN	335 kN	90 : 1	≤ 0.1°	205 kg
35408 lbf.ft	150×10 ³ lbf.ft	132.7×10 ³ lbf.ft	359×10 ³ lbf	144×10 ³ lbf	87×10 ³ lbf	75×10 ³ lbf			

"A" VIEW AS INPUT IS ALLOWED
输入端允许在“A”向视图

SPECIAL DESIGN BASE ON CUSTOMER'S REQUIREMENT
可根据顾客的要求进行非标设计

- NOTICE 注意**
- Please be sure to remain under the curve. 选型时请确保实际载荷在曲线范围内。
 - This drawing is just for your reference. 以上图纸仅供参考。
 - This drawing is subject to change due to new design without prior notice. 本公司保留改进产品的权利而不再另行通知。
 - Please contact the technical department for dimensions and performance parameters of the drives. 如果需要装置的外形尺寸和性能参数, 请与技术部门联系。

HSE25



UNITS/单位:mm
1inch=25.4mm
Weight:255kg

FRONT VIEW
正视图

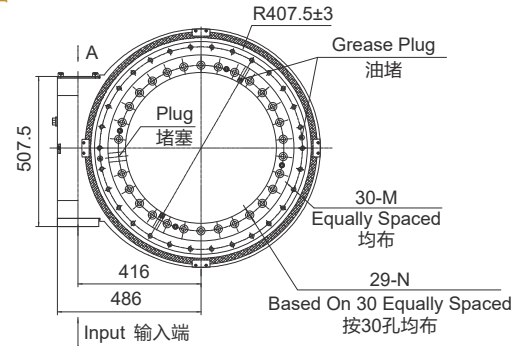

INPUT 输入端视图

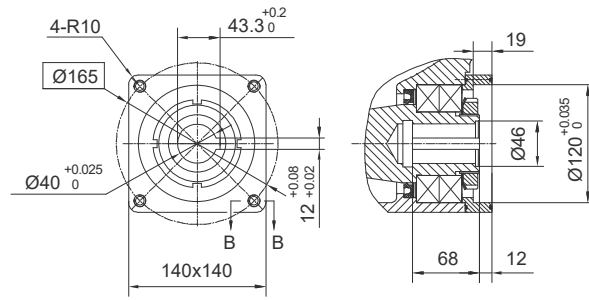

SIDE VIEW
侧视图

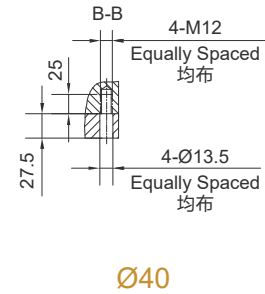
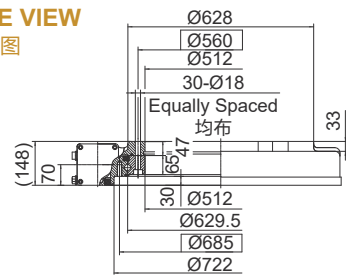

承载力矩图 MOMENT LOAD CHART

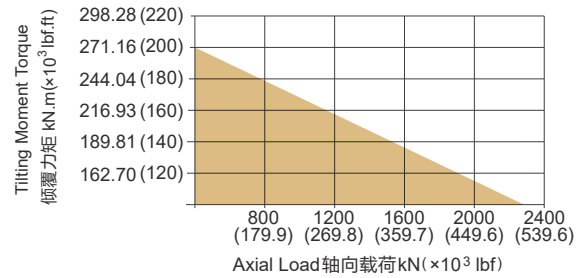

安装孔选项 Mounting Holes Option

Code 代码	M (Outer Ring 外圈)	N (Inner Ring 内圈)
—	M16×2 Tap (攻深)40	Ø18 Thru (通孔) □Ø30 T 17
T	M16×2 Tap (攻深)40	Ø18 Thru (通孔) □Ø30 T 17
B	5/8"-11UNC-2B Tap (攻深)40	Ø18 Thru (通孔) □Ø30 T 17
BT	5/8"-11UNC-2B Tap (攻深)40	Ø18 Thru (通孔) □Ø30 T 17

性能参数表 Slewing Drive Performance Parameters

Output Torque	Max Output Torque	Tilting Moment Torque	Static Axial Rating	Static Radial Rating	Dynamic Axial Rating	Dynamic Radial Rating	Gear Ratio	Tracking Precision	Weight
输出转矩	最大转矩	倾覆力矩	轴向静载荷	径向静载荷	轴向动载荷	径向动载荷	减速比	精度等级	重量
25 kN.m	30 kN.m	180 kN.m	2360 kN	945 kN	590 kN	470 kN	94 : 1	≤ 0.15°	255 kg
18439 lbf.ft	22140 lbf.ft	132.8×10³ lbf.ft	531×10³ lbf	212×10³ lbf	133×10³ lbf	106×10³ lbf			

"A" VIEW AS INPUT IS ALLOWED
输入端允许在 "A" 向视图

SPECIAL DESIGN BASE ON CUSTOMER'S REQUIREMENT
可根据顾客的要求进行非标设计

- NOTICE**
- Please be sure to remain under the curve. 选型时请确保实际载荷在曲线范围内。
 - This drawing is just for your reference. 以上图纸仅供参考。
 - This drawing is subject to change due to new design without prior notice. 本公司保留改进产品的权利而不再另行通知。
 - Please contact the technical department for dimensions and performance parameters of the drives. 如果需要装置的外形尺寸和性能参数, 请与技术部门联系。

HSE25-2



UNITS/单位:mm
1inch=25.4mm
Weight:275kg

FRONT VIEW
正视图

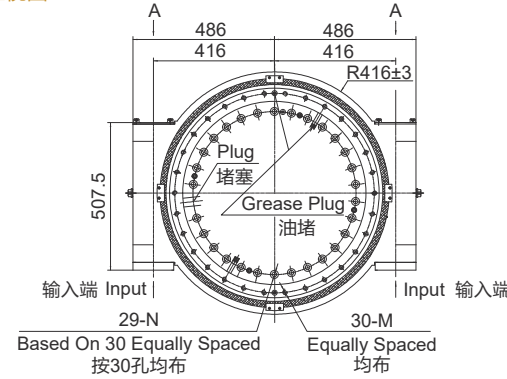

INPUT 输入端视图

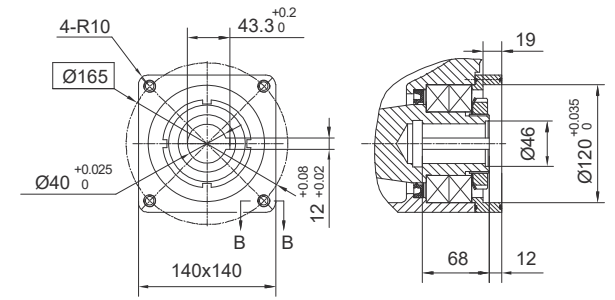

SIDE VIEW
侧视图

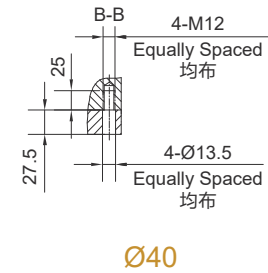
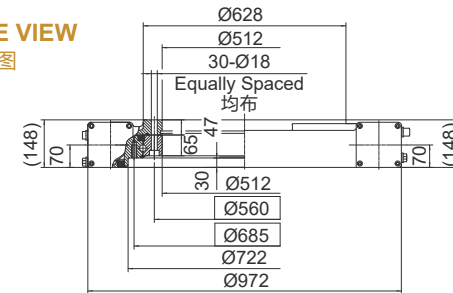

承载力矩图 MOMENT LOAD CHART

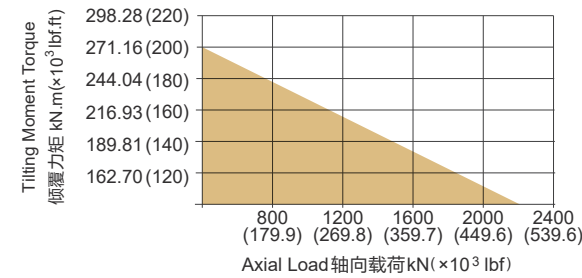

安装孔选项 Mounting Holes Option

Code 代码	M (Outer Ring 外圈)	N (Inner Ring 内圈)
—	M16×2 Tap (攻深)40	Ø18 Thru (通孔) □Ø30 T 17
T	M16×2 Tap (攻深)40	Ø18 Thru (通孔) □Ø30 T 17
B	5/8"-11UNC-2B Tap (攻深)40	Ø18 Thru (通孔) □Ø30 T 17
BT	5/8"-11UNC-2B Tap (攻深)40	Ø18 Thru (通孔) □Ø30 T 17

性能参数表 Slewing Drive Performance Parameters

Output Torque	Max Output Torque	Tilting Moment Torque	Static Axial Rating	Static Radial Rating	Dynamic Axial Rating	Dynamic Radial Rating	Gear Ratio	Tracking Precision	Weight
输出转矩	最大转矩	倾覆力矩	轴向静载荷	径向静载荷	轴向动载荷	径向动载荷	减速比	精度等级	重量
50 kN.m	60 kN.m	180 kN.m	2360 kN	945 kN	590 kN	470 kN	94 : 1	≤ 0.15°	275 kg
36878 lbf.ft	44280 lbf.ft	132.8×10³ lbf.ft	531×10³ lbf	212×10³ lbf	133×10³ lbf	106×10³ lbf			

"A" VIEW AS INPUT IS ALLOWED
输入端允许在 "A" 向视图

SPECIAL DESIGN BASE ON CUSTOMER'S REQUIREMENT
可根据顾客的要求进行非标设计

- NOTICE**
- Please be sure to remain under the curve. 选型时请确保实际载荷在曲线范围内。
 - This drawing is just for your reference. 以上图纸仅供参考。
 - This drawing is subject to change due to new design without prior notice. 本公司保留改进产品的权利而不再另行通知。
 - Please contact the technical department for dimensions and performance parameters of the drives. 如果需要装置的外形尺寸和性能参数, 请与技术部门联系。

HESPN-0223

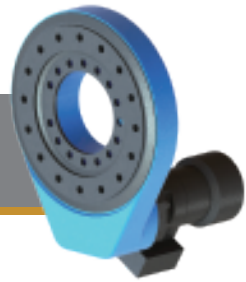

UNITS/单位:mm
1inch=25.4mm
Weight:53kg

FRONT VIEW
正视图

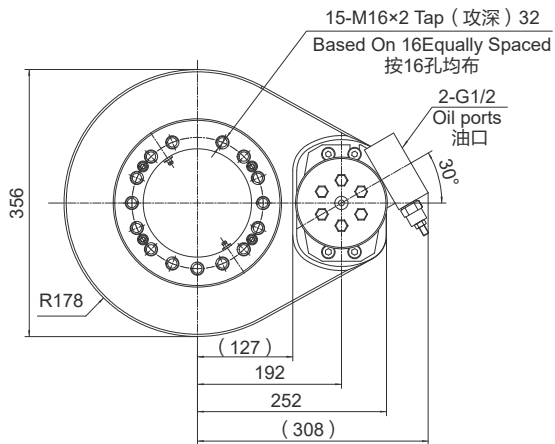

- 齿轮传动性能参数 Spur gear Drive Performance Parameters -

Module 模数	4
GearRatio 减速比	5.33
Static Radial Rating 径向静载荷	135 kN
Static Axial Rating 轴向静载荷	338 kN
Dynamic Radial Rating 径向动载荷	71 kN
Dynamic Axial Rating 轴向动载荷	81 kN
Rated Torque 额定转矩	3216 N.m
Rated Speed 额定转速	5.06 rpm

- 液压马达性能参数 Hydraulic Motor Performance Parameters -

Motor Displacement 排量 (ml/r)	625
Flow 流量 (lpm)	20
Pressure 压力 (Mpa)	8.5
Torque 转矩 (N.m)	710
Speed 转速 (rpm)	27

SIDE VIEW
侧视图

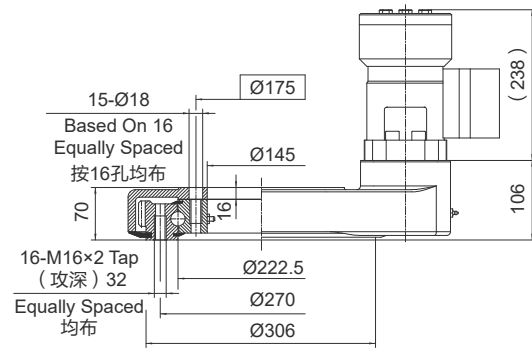

承载曲线图 MOMENT LOAD CHART

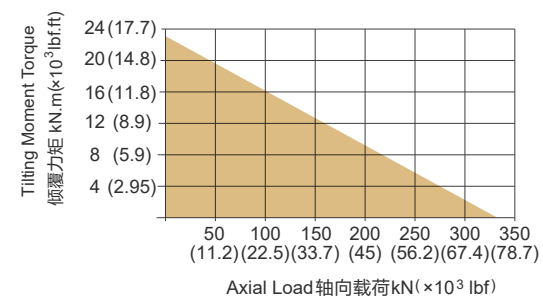

SPECIAL DESIGN BASE ON CUSTOMER'S REQUIREMENT
可根据顾客的要求进行非标设计

- NOTICE 注意**
- Please be sure to remain under the curve. 选型时请确保实际载荷在曲线范围内。
 - This drawing is just for your reference. 以上图纸仅供参考。
 - This drawing is subject to change due to new design without prior notice. 本公司保留改进产品的权利而不再另行通知。
 - Please contact the technical department for dimensions and performance parameters of the drives. 如果需要装置的外形尺寸和性能参数, 请与技术部门联系。

HESPH-0480



UNITS/单位:mm
1inch=25.4mm
Weight:131kg

FRONT VIEW
正视图

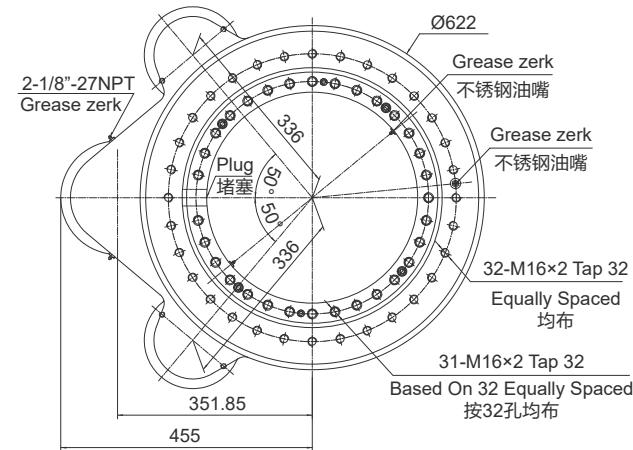

INPUT 输入端视图

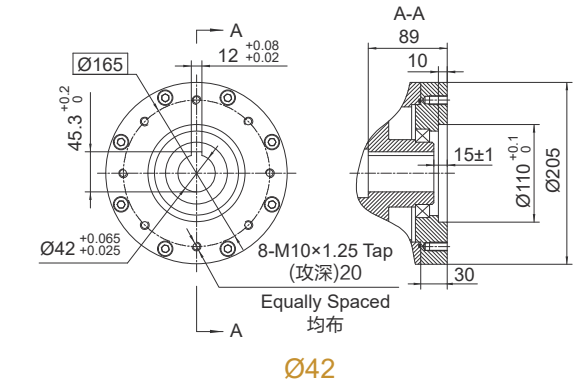

- 齿轮传动性能参数 Spur gear Drive Performance Parameters -

Module 模数	8
GearRatio 减速比	4.8
Radial Load (Max.) 径向载荷	1000 kN
Axial Load (Max.) 轴向载荷	2800 kN
Output Torque (Max.) 输出转矩	18.5 kN.m
Tilting moment (Max.) 倾覆力矩	250 kN.m
Number of teeth (wheel) 大齿轮齿数	72
Number of teeth (pinion) 小齿轮齿数	15

SIDE VIEW
侧视图

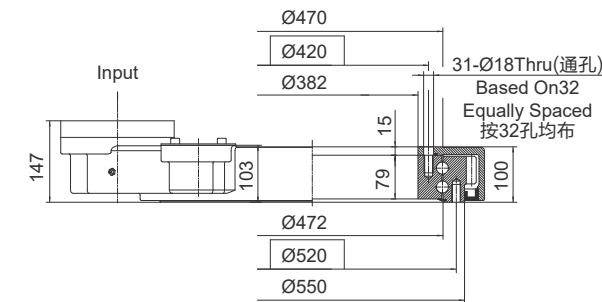

承载曲线图 MOMENT LOAD CHART

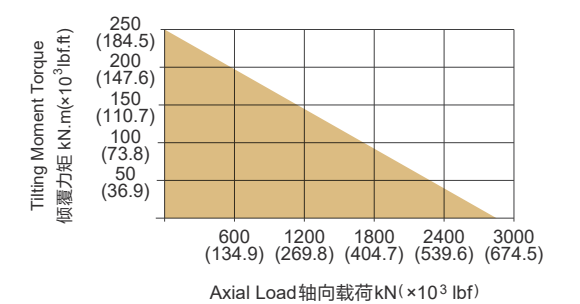

SPECIAL DESIGN BASE ON CUSTOMER'S REQUIREMENT
可根据顾客的要求进行非标设计

- NOTICE 注意**
- Please be sure to remain under the curve. 选型时请确保实际载荷在曲线范围内。
 - This drawing is just for your reference. 以上图纸仅供参考。
 - This drawing is subject to change due to new design without prior notice. 本公司保留改进产品的权利而不再另行通知。
 - Please contact the technical department for dimensions and performance parameters of the drives. 如果需要装置的外形尺寸和性能参数, 请与技术部门联系。

WHEEL DRIVE 行走驱动

1000 Series

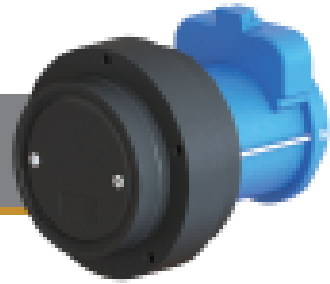

UNITS/单位:mm
1inch=25.4mm
Weight:53.5kg

TOP VIEW
俯视图

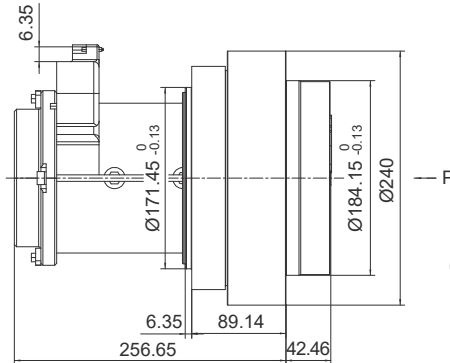

FRONT VIEW
正视图

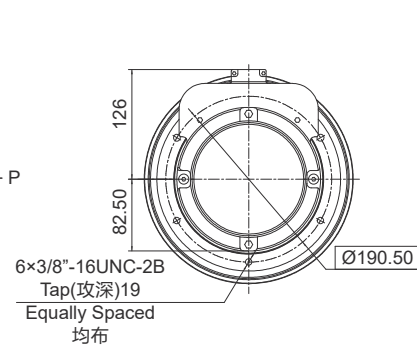

VIEW P
P 向

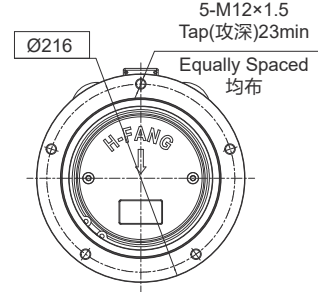

行走驱动 性能参数表 Wheel Drive Performance Parameters

Item 项目	DC Drive Parameters(直流电驱参数)	AC Drive Parameters(交流电驱参数)
Application Type 适用整机类型	8-14m Scissor Lift(Electric Drive) (8-14m电驱剪叉)	14-16m Scissor Lift(Electric Drive) (14-16m电驱剪叉)
Gradeability 适用整机爬坡能力	25%	25%
Ratio 减速机总速比	45.13:1	45.13:1
Output Type 减速机输出型式	Hub Output(轮毂输出)	Hub Output(轮毂输出)
Rated Output Torque(Nm) 额定输出扭矩(Nm)	395	500
Output Torque(Max.)(Nm) 最大输出扭矩(Nm)	790	1000
Rim Bolts Circle Diameter(mm) 轮辋螺栓中心圆直径(mm)	216	216
Rim Bolts Specification 轮辋螺栓规格	5-M12x1.5	5-M12x1.5
Rim Pilot Diameter (mm) 轮辋止口直径(mm)	184.15 ⁰ _{-0.13}	184.15 ⁰ _{-0.13}
Outer Diameter of Reducer Housing(Max.)(mm) 减速机壳体最大外径(mm)	240	240
Frame Installation Pilot Depth(mm) 车架安装止口深度(mm)	6.35	6.35
Frame Installation Pilot Diameter(mm) 车架安装止口直径(mm)	171.45 ⁰ _{-0.13}	171.45 ⁰ _{-0.13}
Frame Mounting Bolts Circle Diameter(mm) 车架安装螺栓中心圆直径(mm)	190.50	190.50
Frame Mounting Bolts Specification 车架安装螺栓规格	6-3/8"-16UNC	6-3/8"-16UNC
Distance from Rim Mounting Surface to Motor Rear(mm) 尾轮辋安装面到电机端尺寸(mm)	256/218	258
Voltage(V) 电机电压(V)	24V DC Motor(24V直流电机)	24V AC Motor(24V直流电机)
Power(W) 电机功率(W)	800	870/1000
Rated Braking Torque(Nm) 制动器额定制动扭矩(Nm)	20	20

SPECIAL DESIGN BASE ON CUSTOMER'S REQUIREMENT
可根据顾客的要求进行非标设计



NOTICE 注意
• This drawing is just for your reference. 以上图纸仅供参考。
• This drawing is subject to change due to new design without prior notice. 本公司保留改进产品的权利而不再另行通知。

WHEEL DRIVE 行走驱动

4000 Series



UNITS/单位:mm
1inch=25.4mm
Weight:39.9kg

SIDE VIEW
侧视图

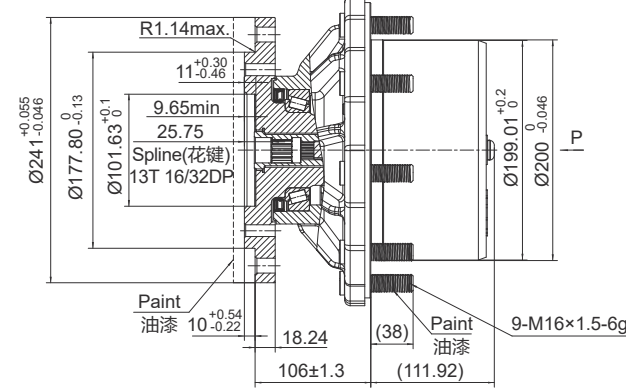

FRONT VIEW
正视图

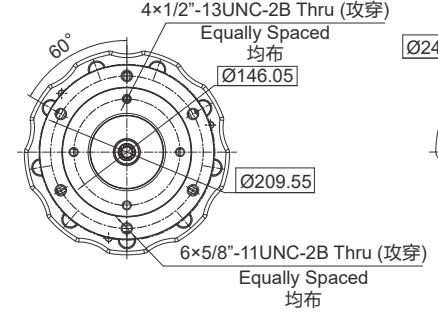

VIEW P
P 向

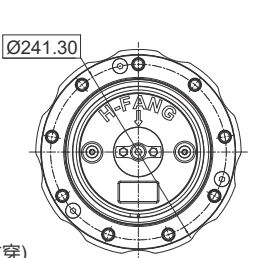

行走驱动 性能参数表 Wheel Drive Performance Parameters

Item 项目	DC Drive Parameters(直流电驱参数)
Application Type 适用整机类型	14-16m Articulating Boom Lift(Electric Drive)(14-16m电驱动曲臂高空车)
Gradeability 适用整机爬坡能力	45%
Ratio 减速机总速比	64.08:1
Output Type 减速机输出型式	Hub Output(轮毂输出)
Rated Output Torque(Nm) 额定输出扭矩(Nm)	2800
Output Torque(Max.)(Nm) 最大输出扭矩(Nm)	5600
Rim Bolts Circle Diameter(mm) 轮辋螺栓中心圆直径(mm)	241.30
Rim Bolts Specification 轮辋螺栓规格	9-M16x1.5
Rim Pilot Diameter (mm) 轮辋止口直径(mm)	200 ⁰ _{-0.046}
Outer Diameter of Reducer Housing(Max.)(mm) 减速机壳体最大外径(mm)	278
Frame Installation Pilot Depth(mm) 车架安装止口深度(mm)	10 ^{+0.54} _{-0.22}
Frame Installation Pilot Diameter(mm) 车架安装止口直径(mm)	177.80 ⁰ _{-0.13}
Frame Mounting Bolts Circle Diameter(mm) 车架安装螺栓中心圆直径(mm)	209.55
Frame Mounting Bolts Specification 车架安装螺栓规格	6-5/8"-11UNC
Total Length of Reducer(mm) 减速机总长度(mm)	216
Voltage(V) 电机电压(V)	101.63 ⁰ _{-0.13}
Power(W) 电机功率(W)	11 ^{+0.30} _{-0.46}
Rated Braking Torque(Nm) 制动器额定制动扭矩(Nm)	13T-16/32 DP

SPECIAL DESIGN BASE ON CUSTOMER'S REQUIREMENT
可根据顾客的要求进行非标设计



NOTICE 注意
• This drawing is just for your reference. 以上图纸仅供参考。
• This drawing is subject to change due to new design without prior notice. 本公司保留改进产品的权利而不再另行通知。