



Cone Drive

ACCUDRIVE  
SERIES RG

# ACCUDRIVE PRECISION PRODUCTS

Now you can get design flexibility and lasting performance from our complete family of AccuDrive Precision Products.

## Model RG Right Angle Gearhead

Output torque capacity up to 8,500 lb.in.  
Motor sizes (standard), adapters to fit servo motors, NEMA and IEC  
Center distance 1.5 to 3.5 inches  
Input power ratings up to 27 H.P, speed range up to 4,000 RPM  
Sizes available 15, 20, 25, 30 and 35  
Universal Mounting with shaft mount and flange mount standard  
in single reduction type  
Gear ratios from 5:1 to 60:1



## Series S Servo Gearhead

Economical Servo Solution  
Output torque up to 7,540 lb.In.  
Motor adapters to fit servo motors  
Center distance from 1.33 inch up to 3.54 inch  
Speed range up to 4,000 RPM  
Flexible mounting (hollow output standard with plug in solid shaft)  
Ratios from 5:1 to 60:1

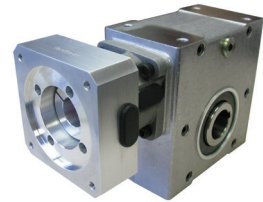

## Series P In-line Planetary Servo Gearhead

Output torque capacity up to 21,240 lb.in. (2,400 Nm)  
Speed range up to 6,000 RPM input.  
Sizes available 42, 60, 90, 120, 140, 180, 220 (S-Type)  
Sizes available 60, 75, 100, 140, 180, 210, 240 (P-Type)  
Gear ratios from 3:1 to 100:1 available from stock (S-Type & P-T)  
Universal Mounting with shaft mount and flange mount standard.  
Three arcminutes backlash or better.

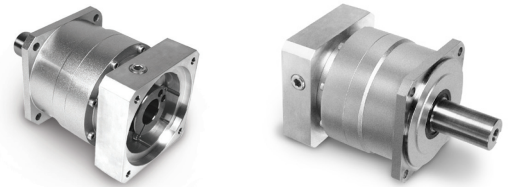

## Series E & LE In-line Planetary Servo Gearhead

Output torque capacity up to 7,080 lb.in.  
Speed range up to 6,000 RPM input.  
Sizes 40, 60, 90, 115, 512 and 160 (Series E)  
Gear ratios from 3:1 to 64:1 (Series E)  
Sizes 50, 70, 90, 120, 155, 205, 235 (Series LE)  
Gear ratios from 3:1 to 100:1 (Series LE)  
Universal Mounting with shaft mount and flange mount standard.  
Backlash as low as eight arcminutes (Series E) and five arcminutes (Series LE)



## ABSOLUTE ZERO Backlash AccuDrive Gearing

Unique design captures both sides of the gear tooth to completely eliminate backlash. Automatically compensates for wear-guaranteed zero backlash for the life of the gearset. Available for single, double and triple reduction types, gear sets, special designs and the Series W.

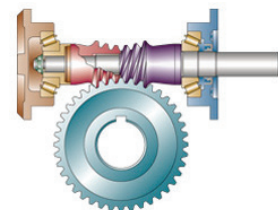

## Hollow Shaft Standard

- Compact mounting saves space
- No coupling required saves costs
- Solid shaft also available for maximum flexibility

## Easy Motor Mounting

- Integrated zero backlash coupling provides fast, error-free alignment
- Integrated motor flange mounts directly to your servo motor

## Maintenance Free

- Factory filled with synthetic gear oil
- No lubrication service throughout unit life
- Double oil seals on all shafts ensure worry-free operation

Our AccuMate® program can help you select the right servo gearhead for your application.

Visit <http://www.conetools.com/Accudrive> to start using AccuMate®.

**AccuMate®**  
SERVO GEARHEAD SELECTION PROGRAM

## Cone Drive Gearing

- High torque capacity
- High efficiency
- Backlash as low as 6 arc minutes
- Quiet and smooth running
- Exact ratios 5:1 and 60:1 in a single stage

## Free Model RG Application Assistance

To ensure optimum performance, our Application Engineers can help you design the ideal servo mechanical drive system for your particular application.

We're available to further discuss the Model RG design characteristics and help with specifying backlash, gear ratios, and speeds.

Call and tell us about your application

The screenshot shows the Cone Drive website interface. At the top, there is a navigation bar with the Cone Drive logo and "GEARING SOLUTIONS". Below the logo, there are links for "Contact Us", "Cone Drive", and "Cone Tools". The main content area is divided into two sections: "AccuMate Selection Tool" and "Drawing Download Tool". The "AccuMate Selection Tool" section features a "Step 3 - Series W Selected" heading and a table of product specifications. The "Drawing Download Tool" section includes a search bar with the part number "W04415.S5A83DHLK" and a "Click here to register and download drawing file" button. Below the search bar is a 3D model of a servo gearhead. At the bottom of the page, there is a copyright notice: "© Copyright 2007 Cone Drive Operations, Inc. All Rights Reserved".

Call us Toll free at 888-994-2663

# Table of contents

Unit Designations -----	5
Motor Mounting Codes-----	6
Selection Criteria for Optimum Performance -----	7
Torque Rating for RG -----	8
Selection Model RG for Motion Control Application -----	9
Dimensional Data Standard Hollow Shaft Dimensions-----	10
Dimensional Data Optional Solid Shaft Dimensions -----	11
Dimensional Data Shrink Disc and Output Flange -----	12
Ratings -----	13

## **INSTALLATION AND MAINTENANCE**

Installation, Operation & Maintenance Instructions -----	18
Product Safety -----	19

# Model RG

## Unit Designation

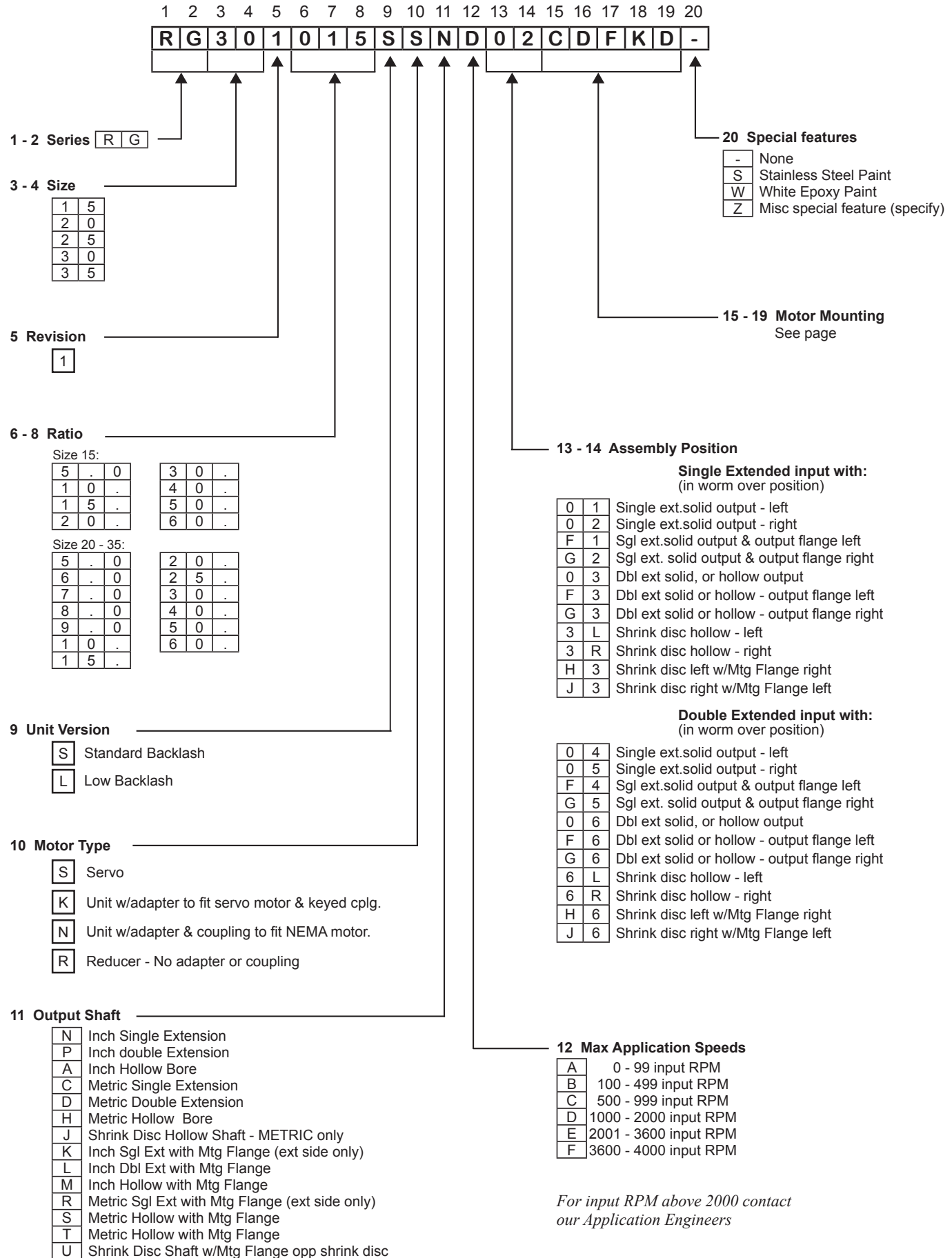

### Servo Motor Flange Selection

1. Go to the appropriate table for the unit size you have selected.
2. Select the appropriate codes for columns 15 - 19 to match the dimensions on your servo motor flange.
3. Make sure your motor length fits the range accommodated by flange square for the size unit you're specifying.
4. If you can't locate the appropriate code for your motor or need assistance, please contact us.

#### RG15 & RG20

##### Motor Flange Square

Column 15 Entry	Flange Square (mm)		90		115		130		140	
	Acceptable Motor Shaft Length		22-45	46-65	22-39	40-65	40-47	48-73	48-73	
	Unit Size	RG15 & RG20	B	M	C	D	E	F	G	

##### NEMA MOTORS FOR RG20 ONLY

Column 15 Entry	Unit Size	56C	143TC / 145TC	182TC / 184TC
	RG20	2	3	4

(For NEMA motors use a "-" in columns 16, 17, 18 & 19)

##### Motor Pilot Diameter

Column 16 Entry	Motor Pilot Diameter (mm)											
	38.15	40	50	55.55	60	70	73.07	80	95	110	114.3	130
	A	B	C	N	D	E	F	G	H	J	K	L

##### Bolt Circle Diameter

Column 17 Entry	Bolt Circle Diameter (mm)																
	63	65	66.68	70	75	80	85	90	95	98.43	100	115	125.73	130	145	149	165
	A	B	C	D	E	F	U	G	H	J	K	L	T	M	N	P	Q

##### Motor Mounting Bolt Size

Column 18 Entry	Motor Flange Thru Hole Size	4.5 - 5.2		5.3 - 6.3		6.4 - 8.3		8.4 - 10.3		10.4 - 12.4		12.5 - 15.0	
		A		B		C		D		E		F	
	Motor Flange Tapped Holes	M4	M5	M6	M8	M10	M12	1/4 - 20	3/8 - 16	1/2 - 13			
		G	H	J	K	L	M	N	P	Q			

##### Motor Shaft Diameter

Column 19 Entry	Motor Shaft Diameter (mm)													
	9.525	11	12	12.7	14	15.875	16	19	19.05	22	22.225	24	25.4	28
	B	D	E	F	G	H	J	K	L	M	N	P	Q	R

#### RG25, RG30 & RG35

##### Motor Flange Square

Column 15 Entry	Flange Square (mm)		115		140		190		
	Acceptable Motor Shaft Length		20-32	33-60	38-56	57-80	38-53	54-65	68-85
	Unit Size	RG25, RG30 & RG35	C	D	G	H	K	S	T

##### NEMA MOTORS FOR RG25, RG30, RG35

Column 15 Entry	Unit Size	56C	143TC / 145TC	182TC / 184TC	213TC / 215TC
	RG25, RG30, RG35	2	3	4	5

(For NEMA motors use a "-" in columns 16, 17, 18 & 19)

##### Motor Pilot Diameter

Column 16 Entry	Motor Pilot Diameter (mm)					
	80	95	110	114.3	130	180
	G	H	J	K	L	M

##### Bolt Circle Diameter

Column 17 Entry	Bolt Circle Diameter (mm)							
	100	115	130	145	149.23	165	200	215
	K	L	M	N	P	Q	R	S

##### Motor Mounting Bolt Size

Column 18 Entry	Motor Flange Thru Hole Size	6.4 - 8.3		8.4 - 10.3		10.4 - 12.4		12.5 - 15.0	
		C		D		E		F	
	Motor Flange Tapped Holes	M6	M8	M10	M12	1/4 - 20	3/8 - 16	1/2 - 13	
		J	K	L	M	N	P	Q	

##### Motor Shaft Diameter

Column 19 Entry	Motor Shaft Diameter (mm)																
	14	15.875	16	19	19.05	22	22.225	24	25.4	28	28.575	31.75	32	34.925	35	38*	42*
	G	H	J	K	L	M	N	P	Q	R	S	T	U	V	W	X	Y

\*RG35 ONLY

# Model RG

## Selection Criteria for Optimum Performance

### Size and Precision Options

Series RG is available in five case sizes: sizes 15, 20, 25, 30, and 35, and two levels of precision: standard and low backlash. All are right angle, double enveloping worm gear units with a wide range of mounting, motor flange, and output shaft options.

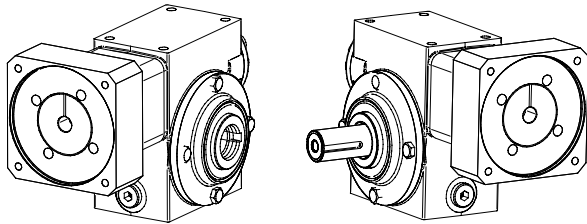

### Backlash

The following chart lists the total assembled nominal backlash for Model RG Right Angle Gearheads. Backlash is defined as the amount of total angular movement of the output shaft with the worm locked and the gear set on exact center distance.

	Unit Sizes				
	15	20	25	30	35
Standard Backlash (arc. mins.)	27	17	14	11	11
Low Backlash (arc. mins.)	11	8	7	5	4

### Service Factor and Backlash

A speed reducer's backlash can be expected to increase with wear. Experience shows that the backlash of a gear unit loaded at or near its rated capacity will grow measurably within the first hundred or so hours of operation. Thereafter, the rate of backlash growth will be greatly reduced. The selection of a gear unit with 1.5 or greater service factor will help significantly in reducing wear related backlash growth.

### Worm Gear Backdriving Considerations

In applications which involve rapid cycling of single stage worm gearing with ratios of 30:1 and above, the backdriving/self-locking performance characteristics make it important to carefully review the torque applied to the input shaft during stopping

and reversing. This is of particular importance when unrestrained high inertia loads are involved. For such situations, we encourage a review with our Application Engineers.

### Torque Ratings

The ratings for Model RG standard and Model RG low backlash units are shown in the table on page . These ratings are based on an input speed of 2000 RPM with a 1.0 service factor. For additional ratings see expanded ratings tables on pages through.

### Cyclical Applications

The "Accel/Decel" torque ratings on page are application design maximums for the start and stop portion of a cyclic load curve, and the "Run" torque ratings are the recommended design maximum for the travel or continuous run portion of a load cycle. The values shown are for a load cycle frequency of 1,000 cycles per hour with a maximum speed reducer speed input of 2,000 RPM. For faster or slower cycle rates, these torque values should be adjusted by dividing the charted torque value by the appropriate "Cycle Shock Factor" as shown. These ratings should also be adjusted for different speed reducer input speeds by dividing the table torque value by the appropriate "Speed Factor" as shown.

### E-Stop

The "E-Stop" torque ratings are the peak output torque ratings for the unit. This peak torque is for occasional momentary overloads. The unit is designed to allow up to 25,000 momentary overloads over the life of the gearhead.

### Thermal Ratings

Most positioning applications are intermittent and heat built up in the gear unit is generally not a concern. However, if the 'on' and 'run' portion of the duty cycle is to exceed 50% of the total cycle time, please contact our Application Engineers for assistance.



Size			Ratio													
			5:1	6:1	7:1	8:1	9:1	10:1	15:1	20:1	25:1	30:1	40:1	50:1	60:1	
15	Output torque (lb.in.)	E-Stop	1620						1920	1911	1848		1701	1314	1326	1134
		Accel/decel	411						523	538	525		504	459	455	423
		Run	314						412	427	422		405	369	366	340
	Input torque	Accel/decel	89						58	41	31		21	15	13	10
		Run	71						48	34	26		18	13	11	9
20	Output torque (lb.in.)	E-Stop	3400	3600	3800	3900	3900	3900	4000	3700	3700	3500	3200	2700	2600	
		Accel/decel	800	880	930	980	1000	1020	1060	1030	1030	990	940	900	870	
		Run	590	650	690	730	740	760	790	790	780	750	720	690	660	
	Input torque	Accel/decel	174	159	146	135	124	113	80	61	50	42	32	25	21	
		Run	130	119	108	101	91	85	61	46	38	32	24	19	16	
25	Output torque (lb.in.)	E-Stop	6600	7100	7300	7600	7700	7800	7800	7500	7000	6900	6000	5500	5400	
		Accel/decel	1474	1632	1718	1816	1850	1895	1964	1920	1918	1839	1752	1688	1620	
		Run	1063	1179	1242	1312	1335	1373	1427	1411	1404	1347	1285	1238	1189	
	Input torque	Accel/decel	320	296	270	249	228	211	149	114	91	77	59	47	39	
		Run	123	214	195	180	165	153	108	83	67	56	42	34	28	
30	Output torque (lb.in.)	E-Stop	11600	12600	13100	13700	13700	13800	13900	13300	12700	12300	11100	9700	9600	
		Accel/decel	2434	2710	2871	3050	3138	3244	3372	3301	3300	3162	3015	2905	2789	
		Run	1738	1940	2060	2196	2258	2337	2433	2411	2404	2303	2197	2116	2032	
	Input torque	Accel/decel	529	491	451	419	387	360	255	196	157	132	102	81	66	
		Run	378	351	323	302	279	260	184	142	114	96	72	58	48	
35	Output torque (lb.in.)	E-Stop	21447	23397	24174	25179	25350	25569	25533	24948	23820	22749	20292	18372	18030	
		Accel/decel	4247	4750	5027	5343	5477	5648	5870	5744	5741	5502	5247	5055	4853	
		Run	3014	3376	3577	3809	3908	4032	4202	4166	4143	3980	3796	3657	3511	
	Input torque	Accel/decel	923	861	789	734	676	628	445	342	277	232	175	140	117	
		Run	662	618	562	529	482	453	322	248	207	168	127	102	85	

Torque ratings based on 2000 RPM, service factor 1.0.

Cycle Shock Factors	
Cycles / Hour	Shock Factor
1 to 500	0.8
1000	1.0
1500	1.2
2500	1.4
3500	1.6

one cycle = one acceleration and one deceleration.

Note: use straight line interpolation for intermediate cycle rates.

Speed Factors	
Peak Input Speed (RPM)	Speed Factor
0 to 500	0.65
1000	0.8
2000	1
3000	1.25
4000	1.5
above 4000	contact us

Note: use straight line interpolation for intermediate cycle rates.



# Model RG

## Selection Model RG for Motion Control Application

### Rotational Inertia Values for Model RG Units

Inertia of the complete speed reducer, at the input shaft

Size	Ratio to 1	5	6	7	8	9	10	15	20	25	30	40	50	60
15	Total Inertia - kg cm <sup>2</sup>	1.5					1.3	1.3	1.3		1.3	1.3	1.3	1.3
	Total Inertia - lb-in-s <sup>2</sup> x10 <sup>-4</sup>	13.2					11.7	11.5	11.4		11.3	11.3	11.3	11.3
20	Total Inertia - kg cm <sup>2</sup>	2.6	2.3	2.2	2.1	2.0	2.0	1.9	1.9	1.8	1.8	1.8	1.8	1.8
	Total Inertia - lb-in-s <sup>2</sup> x10 <sup>-4</sup>	22.8	20.7	19.5	18.6	18.1	17.7	16.7	16.4	16.2	16.2	16.1	16.0	16.0
25	Total Inertia - kg cm <sup>2</sup>	6.0	5.2	4.8	4.5	4.3	4.1	3.8	3.6	3.6	3.6	3.5	3.5	3.5
	Total Inertia - lb-in-s <sup>2</sup> x10 <sup>-4</sup>	53.0	46.2	42.1	39.5	37.7	36.4	33.3	32.2	31.7	31.4	31.2	31.0	31.0
30	Total Inertia - kg cm <sup>2</sup>	13.0	10.8	9.5	8.6	8.0	7.6	6.6	6.3	6.1	6.0	5.9	5.9	5.9
	Total Inertia - lb-in-s <sup>2</sup> x10 <sup>-4</sup>	115.1	95.6	83.9	76.3	71.0	67.3	58.4	55.3	53.9	53.1	52.4	52.0	51.8
35	Total Inertia - kg cm <sup>2</sup>	27.6	23.2	20.5	18.8	17.6	16.7	14.7	14.0	13.7	13.5	13.3	13.2	13.2
	Total Inertia - lb-in-s <sup>2</sup> x10 <sup>-4</sup>	244.4	205.1	181.4	166.0	155.5	147.9	130.1	123.8	120.9	119.4	117.8	117.1	116.7

### Torsional Stiffness of Model RG Units at output, input held (less coupling)

		Unit Size									
		15		20		25		30		35	
		Lb.In./min.	Nm /min.	Lb.In./min.	Nm /min.	Lb.In./min.	Nm /min.	Lb.In./min.	Nm /min.	Lb.In./min.	Nm /min.
Stiffness		91	10.3	157	17.8	204	23.1	367	41.6	699	79.2

### Maximum Permissible Overhung Loads

When a sprocket, gear, etc., is mounted on the shaft, a calculation, as shown, must be made to determine the overhung load on the shaft, and the results compared to the maximum permissible overhung loads tabulated. Overhung loads can be reduced by increasing the diameter of the sprockets, gear, etc. If the maximum permissible overhung load is exceeded, the sprocket, gear, etc., should be extended to run in an outboard bearing.

Permissible overhung loads vary according to the direction of rotation. The values tabulated are for the most unfavorable direction with the unit transmitting full rated power and the load applied at the midpoint of the shaft extension. Hence, they can sometimes be increased for a more favorable direction of rotation, or if the power transmitted is less than the rated capacity of the gear unit, or if the load is applied nearer to the gear unit case.

### Overhung Load (lbs.)

$$P = \frac{HP \times 126,000 \times K}{N \times D}$$

Where: P = equivalent overhung load (lb.)  
 HP = power Transmitted by the shaft (HP)  
 N = speed of shaft (RPM)  
 D = pitch diameter pf sprocket, etc. (in.)  
 K = factor

Overhung member	K (factor)
Chain sprocket*	1.00
Spur or helical pinion	1.25
Vee belt sheave	1.50
Flat belt pulley	2.00

\* If multistrand chain is further than dimension "A", contact Cone Drive.

### Solid Gearshaft Overhung Load Ratings

		Unit Size				
		15	20	25	30	35
OHL Value (lbs.)		700	1500	2000	2500	3500

### Distance Midway Along the Shaft Extension

		Unit Size				
		15	20	25	30	35
'A'		0.38	0.75	0.69	1.00	1.31

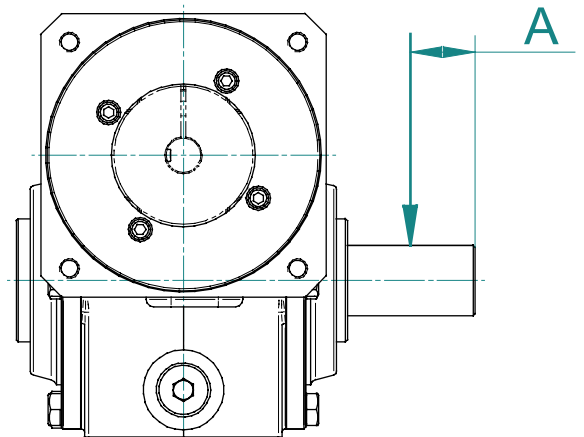

## Dimensional Data Standard Hollow Shaft Dimensions

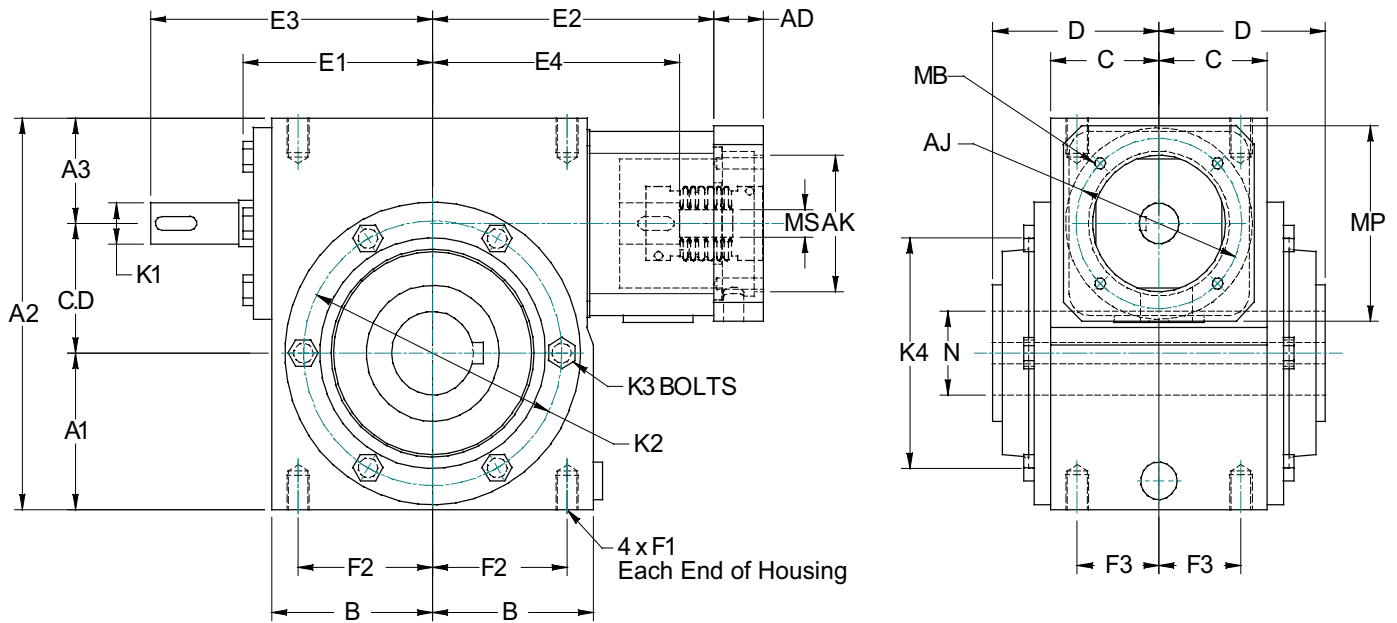

Size	CD		A1		A2		A3		B		C		D	
	inch	mm	inch	mm	inch	mm	inch	mm	inch	mm	inch	mm	inch	mm
15	1.500	38.1	1.625	41.3	4.75	121	1.625	41.3	1.78	45	1.66	42	2.31	59
20	2.000	50.8	2.500	63.5	6.25	159	1.750	44.5	2.41	61	1.57	40	2.63	67
25	2.500	63.5	3.000	76.2	7.50	191	2.000	50.8	3.09	79	1.94	49	2.91	74
30	3.000	76.2	3.625	92.1	9.06	230	2.438	61.9	3.86	98	2.56	65	3.94	100
35	3.500	88.9	4.250	108	10.31	262	2.563	65.1	4.44	113	3.44	87	4.61	117

Size	E1		E2		E3		E4		F1	F2		F3		K1			K2	
	inch	mm	inch	mm	inch	mm	inch	mm	tap	inch	mm	inch	mm	inch	mm	keyway (mm)	inch	mm
15	2.17	55	4.46	113	3.31	84	3.62	91.9	M8	1.44	36.5	1.31	33.4	0.551	14 k6	5 x 2.3 x 16	3.125	79.4
20	2.88	73	5.13	130	4.59	117	4.30	109.2	M10	2.00	50.8	1.13	28.6	0.551	14 k6	5 x 2.3 x 25	4.125	104.8
25	3.65	93	6.25	159	5.25	133	5.44	138.2	M10	2.56	65.1	1.50	38.1	0.748	19 k6	6 x 2.8 x 25	4.938	125.4
30	4.53	115	6.66	169	6.69	170	5.85	148.6	M12	3.19	81	1.94	49.2	0.945	24 k6	8 x 3 x 25	6.125	155.6
35	5.16	131	7.44	189	7.75	197	6.63	168.4	M12	3.81	96.9	2.81	71.5	1.103	28 k6	8 x 4 x 32	7.250	184.2

Size	K3 bolts	K4 pilot dia.		N (inch)			N (mm)			AD Max		AK	AJ	MP	MB	MS	Weight
	mm	inch	mm	inch	tol	keyway	mm	tol	keyway	inch	mm						
15	M6	2.498	63.4	0.876	+/- .001	3/16 x 3/32	25	H7	8 x 3.3	2.055	52.2	Motor Plate Dimensions are made to fit your servo motor. Refer to page for available dimensions.					15
20	M8	3.336	84.7	1.251	+/- .001	1/4 x 1/8	30	H7	8 x 3.3	2.055	52.2						27
25	M8	4.217	107.1	1.688	+/- .001	3/8 x 3/16	35	H7	10 x 3.3	2.717	69.0						44
30	M10	5.342	135.7	1.938	+/- .001	1/2 x 1/4	45	H7	14 x 3.8	2.717	69.0						78
35	M10	6.467	164.3	2.438	+/- .001	5/8 x 5/16	60	H7	18 x 4.4	2.717	69.0						116

# Model RG

## Dimensional Data Optional Solid Shaft Dimensions

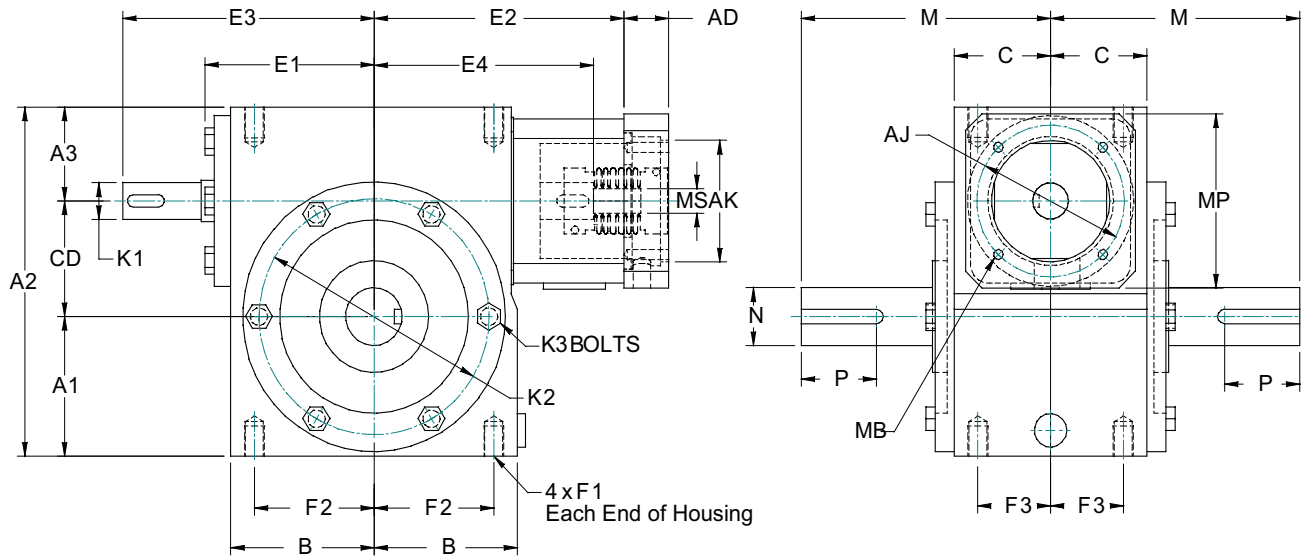

Size	CD		A1		A2		A3		B		C		M	
	inch	mm	inch	mm	inch	mm	inch	mm	inch	mm	inch	mm	inch	mm
15	1.500	38.1	1.625	41.3	4.75	121	1.625	41.3	1.78	45	1.66	42	3.50	89
20	2.000	50.8	2.500	63.5	6.25	159	1.750	44.5	2.41	61	1.57	40	4.63	118
25	2.500	63.5	3.000	76.2	7.50	191	2.000	50.8	3.09	79	1.94	49	4.78	121
30	3.000	76.2	3.625	92.1	9.06	230	2.438	61.9	3.86	98	2.56	65	6.64	169
35	3.500	88.9	4.250	108	10.31	262	2.563	65.1	4.44	113	3.44	87	8.25	210

Size	E1		E2		E3		E4		F1	F2		F3		K1			K2		K3 bolts
	inch	mm	inch	mm	inch	mm	inch	mm		tap	inch	mm	inch	mm	inch	mm	keyway(mm)	inch	
15	2.17	55	4.46	113	3.31	84	3.62	91.9	M8	1.44	36.5	1.31	33.4	0.551	14 k6	5 x 2.3 x 16	3.125	79.4	M6
20	2.88	73	5.13	130	4.59	117	4.30	109.2	M10	2.00	50.8	1.13	28.6	0.551	14 k6	5 x 2.3 x 25	4.125	104.8	M8
25	3.65	93	6.25	159	5.25	133	5.44	138.2	M10	2.56	65.1	1.50	38.1	0.748	19 k6	6 x 2.8 x 25	4.938	125.4	M8
30	4.53	115	6.66	169	6.69	170	5.85	148.6	M12	3.19	81	1.94	49.2	0.945	24 k6	8 x 3 x 25	6.125	155.6	M10
35	5.16	131	7.44	189	7.75	197	6.63	168.4	M12	3.81	96.9	2.81	71.5	1.103	28 k6	8 x 4 x 32	7.250	184.2	M10

Size	N (inch)		P (inch)		N (inch)		P (mm)*			AD Max		AK	AJ	MP	MB	MS	Weight lbs.
	inch	tol	Keyway	length	mm	tol	keyway	length	offset	inch	mm						
15	0.7497	± 0.0003	3/16 x 3/32	0.89	20	k6	6 x 3.5	22	4	2.055	52.2	Motor Plate Dimensions are made to fit your servo motor. Refer to page 4 for available dimensions.					16
20	1.1245	± 0.0005	1/4 x 1/8	1.50	25	k6	8 x 4	36	4	2.055	52.2						28
25	1.2495	± 0.0005	1/4 x 1/8	1.38	30	k6	8 x 4	40	3	2.717	69.0						45
30	1.4995	± 0.0005	3/8 x 3/16	2.00	38	k6	10 x 5	50	3	2.717	69.0						73
35	1.8745	± 0.0005	1/2 x 1/4	2.62	45	k6	14 x 5.5	63	5	2.717	69.0						112

\*Note: P (mm) is length of pocket-style keyway and offset from shaft end.

## Dimensional Data Shrink Disc and Output Flange

SEE PREVIOUS PAGES FOR OTHER DIMENSIONS

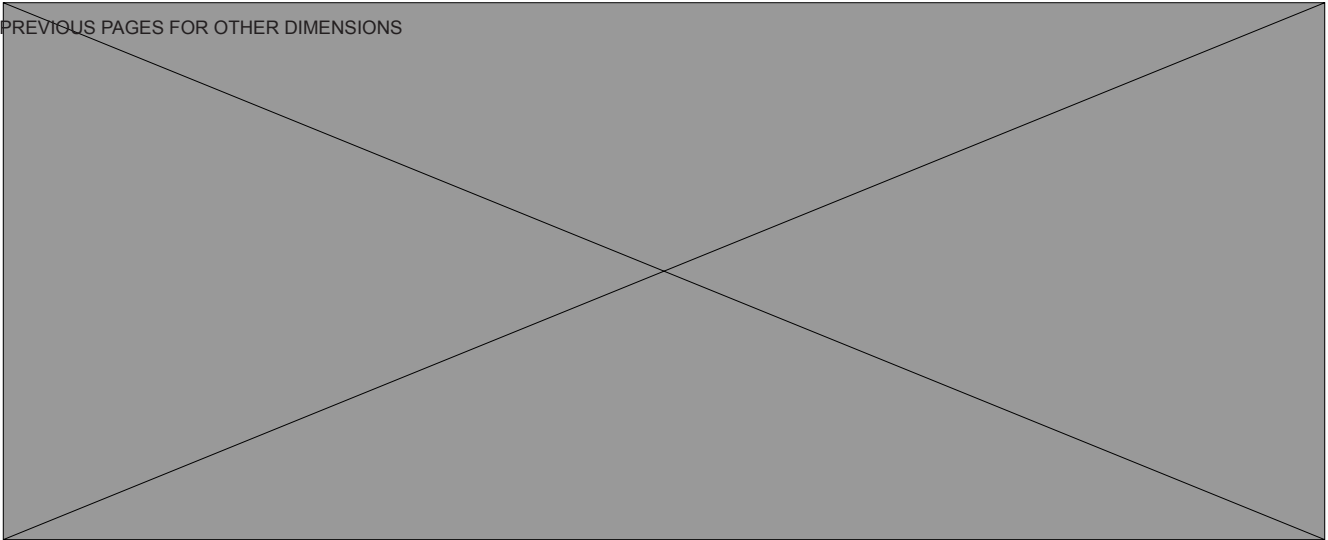

Optional Shrink Disc Hollow Shaft

Size	CD		M		N (mm)		Customer Mating Shaft Diameter		
	inch	mm	inch	mm	mm	+/-	mm	+	-
15	1.50	38	3.26	83	25.005	0.005	25	0	0.010
20	2.00	51	3.65	93	30.005	0.005	30	0	0.010
25	2.50	64	4.29	109	35.008	0.008	35	0	0.016
30	3.00	76	5.31	135	45.008	0.008	45	0	0.016
35	3.50	89	6.06	154	60.010	0.010	60	0	0.020

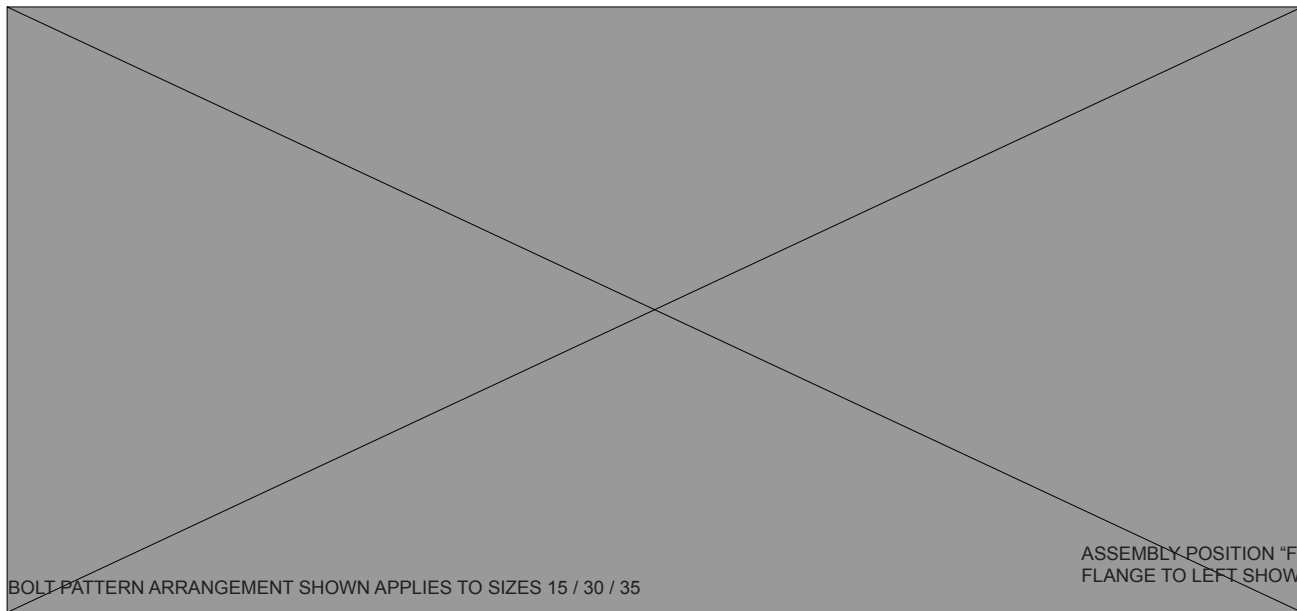

BOLT PATTERN ARRANGEMENT SHOWN APPLIES TO SIZES 15 / 30 / 35

ASSEMBLY POSITION "F3"  
FLANGE TO LEFT SHOWN HERE

Size	CD		A		B		C		D		E		F		G	N (if hollow shaft)	
	inch	mm	inch	mm	inch	mm	inch	mm	inch	mm	inch	mm	inch	mm	degree	mm	tol
15	1.50	38	4.500	114.3	3.40	86	6.63	168	5.88	149	0.41	10	0.38	10	45	25	H7
20	2.00	51	5.376	136.6	3.41	87	8.00	203	7.00	178	0.41	10	0.50	13	90	30	H7
25	2.50	64	6.626	168.3	3.52	89	9.25	235	8.25	210	0.47	12	0.50	13	90	35	H7
30	3.00	76	7.751	196.9	4.35	111	10.50	267	9.50	241	0.56	14	0.50	13	45	45	H7
35	3.50	89	8.751	222.3	5.08	129	11.75	298	10.50	267	0.56	14	0.50	13	45	60	H7

# Model RG

## Ratings

### Model RG Size 15 (expanded rating table)

Ratio		Worm shaft speed (RPM)									
		100	200	300	500	1000	1500	1750	2000	3000	4000
5:1	Input torque (lb.in.)	126	118	112	105	92	81	76	71	59	51
	Input mechanical HP	0.20	0.37	0.53	0.83	1.46	1.92	2.10	2.26	2.80	3.24
	Output torque (lb.in.)	540	512	492	461	411	359	334	214	257	222
	Worm driving efficiency (%)	86	87	88	88	89	89	89	88	87	87
10:1	Input torque (lb.in.)	80	75	72	67	60	54	51	48	40	35
	Input mechanical HP	0.13	0.24	0.34	0.53	0.95	1.28	1.41	1.51	1.89	2.19
	Output torque (lb.in.)	640	618	595	564	523	466	438	412	339	294
	Worm driving efficiency (%)	80	82	83	84	87	87	87	86	85	85
15:1	Input torque (lb.in.)	56	53	50	47	42	38	36	34	28	24
	Input mechanical HP	0.09	0.17	0.24	0.37	0.67	0.90	0.99	1.07	1.33	1.55
	Output torque (lb.in.)	637	617	595	574	538	481	453	427	351	304
	Worm driving efficiency (%)	76	78	79	81	85	85	85	84	83	83
20:1	Input torque (lb.in.)	43	40	38	36	32	29	27	26	22	19
	Input mechanical HP	0.07	0.13	0.18	0.29	0.51	0.69	0.76	0.82	1.02	1.19
	Output torque (lb.in.)	616	598	577	567	525	475	448	422	346	301
	Worm driving efficiency (%)	72	74	75	79	81	82	82	81	80	80
30:1	Input torque (lb.in.)	29	27	26	25	22	20	19	18	15	13
	Input mechanical HP	0.05	0.09	0.12	0.19	0.35	0.47	0.52	0.56	0.71	0.81
	Output torque (lb.in.)	567	552	541	524	504	455	429	405	331	288
	Worm driving efficiency (%)	65	67	69	71	76	77	77	76	75	75
40:1	Input torque (lb.in.)	21	20	19	18	16	14	13	13	11	9
	Input mechanical HP	0.03	0.06	0.09	0.14	0.25	0.34	0.37	0.40	0.50	0.59
	Output torque (lb.in.)	486	475	483	478	459	415	391	369	302	263
	Worm driving efficiency (%)	58	60	64	68	72	73	73	72	71	71
50:1	Input torque (lb.in.)	17	16	16	15	13	12	11	11	9	8
	Input mechanical HP	0.03	0.05	0.07	0.12	0.21	0.28	0.31	0.34	0.42	0.49
	Output torque (lb.in.)	442	467	476	476	455	412	388	366	299	260
	Worm driving efficiency (%)	51	57	61	65	69	70	70	69	68	68
60:1	Input torque (lb.in.)	14	13	13	12	11	10	9	9	7	6
	Input mechanical HP	0.02	0.04	0.06	0.09	0.17	0.23	0.25	0.27	0.34	0.39
	Output torque (lb.in.)	421	445	439	438	423	383	361	340	278	242
	Worm driving efficiency (%)	50	56	58	62	66	67	67	66	65	65

### Model RG Size 20 (expanded rating table)

Ratio		Worm shaft speed (RPM)									
		100	200	300	500	1000	1500	1750	2000	3000	4000
5:1	Input torque (lb.in.)	252	230	218	204	174	147	137	129	106	91
	Input mechanical HP	0.40	0.73	1.04	1.62	2.76	3.48	3.80	4.09	5.05	5.76
	Output torque (lb.in.)	1121	1035	994	929	800	675	626	593	483	408
	Worm driving efficiency (%)	89	90	91	91	92	92	92	92	91	90
6:1	Input torque (lb.in.)	226	211	202	186	160	136	127	119	98	84
	Input mechanical HP	0.36	0.67	0.96	1.48	2.54	3.25	3.53	3.77	4.68	5.34
	Output torque (lb.in.)	1195	1127	1089	1016	883	749	696	656	537	454
	Worm driving efficiency (%)	88	89	90	91	92	91	91	91	91	90
7:1	Input torque (lb.in.)	222	192	181	169	146	124	115	109	90	77
	Input mechanical HP	0.35	0.61	0.86	1.34	2.31	2.95	3.21	3.45	4.28	4.90
	Output torque (lb.in.)	1260	1184	1125	1064	929	791	734	692	566	481
	Worm driving efficiency (%)	87	88	89	90	91	91	91	91	90	89
8:1	Input torque (lb.in.)	188	176	168	155	134	115	108	101	83	72
	Input mechanical HP	0.30	0.50	0.80	1.23	2.13	2.75	2.99	3.20	3.97	4.56
	Output torque (lb.in.)	1291	1228	1183	1107	979	837	778	734	600	511
	Worm driving efficiency (%)	86	87	88	89	91	91	90	91	90	89
9:1	Input torque (lb.in.)	168	161	151	142	123	105	98	92	77	66
	Input mechanical HP	0.27	0.51	0.72	1.13	1.96	2.51	2.73	2.92	3.64	4.19
	Output torque (lb.in.)	1289	1243	1184	1125	1000	855	794	746	613	523
	Worm driving efficiency (%)	85	86	87	88	90	90	90	90	89	88
10:1	Input torque (lb.in.)	157	148	139	131	113	98	91	85	71	61
	Input mechanical HP	0.25	0.47	0.66	1.04	1.80	2.33	2.53	2.71	3.37	3.88
	Output torque (lb.in.)	1307	1258	1192	1140	1021	877	816	768	630	538
	Worm driving efficiency (%)	83	85	86	87	90	90	90	90	89	88
15:1	Input torque (lb.in.)	111	104	99	91	80	69	64	60	50	43
	Input mechanical HP	0.18	0.33	0.47	0.72	1.27	1.65	1.79	1.92	2.39	2.75
	Output torque (lb.in.)	1310	1263	1214	1159	1056	911	847	798	655	559
	Worm driving efficiency (%)	79	81	82	84	88	88	88	878	86	86
20:1	Input torque (lb.in.)	82	79	75	69	61	53	50	46	39	33
	Input mechanical HP	0.13	0.25	0.36	0.88	0.97	1.27	1.38	1.46	1.84	2.12
	Output torque (lb.in.)	1228	1213	1169	1143	1027	902	838	783	649	554
	Worm driving efficiency (%)	75	77	78	83	84	85	85	85	84	83
25:1	Input torque (lb.in.)	68	64	60	56	49	43	40	37	31	27
	Input mechanical HP	0.11	0.20	0.29	0.44	0.77	1.02	1.11	1.19	1.48	1.71
	Output torque (lb.in.)	1209	1194	1161	1134	1020	898	835	787	645	552
	Worm driving efficiency (%)	71	75	77	81	84	84	84	84	83	82
30:1	Input torque (lb.in.)	57	54	50	47	41	36	34	32	26	23
	Input mechanical HP	0.09	0.17	0.24	0.37	0.65	0.86	0.93	1.00	1.25	1.44
	Output torque (lb.in.)	1157	1125	1089	1063	985	862	801	756	622	531
	Worm driving efficiency (%)	68	70	72	75	80	80	80	80	79	78
40:1	Input torque (lb.in.)	43	40	38	35	32	27	25	24	20	17
	Input mechanical HP	0.07	0.13	0.18	0.27	0.51	0.65	0.70	0.75	0.94	1.08
	Output torque (lb.in.)	1048	1013	1020	1011	940	822	764	718	592	503
	Worm driving efficiency (%)	61	63	67	72	74	76	76	76	75	74
50:1	Input torque (lb.in.)	34	32	31	28	25	22	20	19	16	14
	Input mechanical HP	0.05	0.10	0.15	0.22	0.40	0.52	0.56	0.61	0.76	0.89
	Output torque (lb.in.)	930	967	978	971	907	792	736	689	567	486
	Worm driving efficiency (%)	54	60	64	68	72	73	73	73	71	69
60:1	Input torque (lb.in.)	29	27	25	24	21	18	17	16	13	11
	Input mechanical HP	0.05	0.09	0.12	0.19	0.33	0.43	0.47	0.51	0.63	0.72
	Output torque (lb.in.)	915	952	933	929	869	761	706	662	548	463
	Worm driving efficiency (%)	53	59	61	65	70	70	70	70	69	67

# Model RG

## Ratings

### Model RG Size 25 (expanded rating table)

Ratio		Worm shaft speed (RPM)									
		100	200	300	500	1000	1500	1750	2000	3000	4000
5:1	Input torque (lb.in.)	491	452	429	396	320	266	248	231	187	155
	Input mechanical HP	0.78	1.43	2.04	3.14	5.09	6.32	6.88	7.34	8.92	9.86
	Output torque (lb.in.)	2187	2033	1953	1801	1474	1219	1133	1063	852	699
	Worm driving efficiency (%)	89	90	91	91	92	92	92	92	91	90
6:1	Input torque (lb.in.)	450	415	394	361	296	246	229	214	173	145
	Input mechanical HP	0.71	1.32	1.88	2.86	4.69	5.86	6.37	6.78	8.26	9.19
	Output torque (lb.in.)	2378	2217	2128	1970	1632	1351	1254	1179	947	782
	Worm driving efficiency (%)	88	89	90	91	92	91	91	92	91	90
7:1	Input torque (lb.in.)	431	374	354	326	270	223	209	195	159	134
	Input mechanical HP	0.68	1.19	1.69	2.59	4.28	5.31	5.79	6.19	7.57	8.48
	Output torque (lb.in.)	2444	2302	2208	2053	1718	1421	1325	1242	1001	832
	Worm driving efficiency (%)	87	88	89	90	91	91	91	91	90	89
8:1	Input torque (lb.in.)	369	310	327	302	249	208	194	180	147	124
	Input mechanical HP	0.59	0.98	1.56	2.40	3.96	4.95	5.40	5.72	7.01	7.90
	Output torque (lb.in.)	2539	2402	2303	2150	1816	1506	1405	1312	1060	886
	Worm driving efficiency (%)	86	87	88	89	91	91	90	91	90	89
9:1	Input torque (lb.in.)	336	312	296	274	228	190	177	165	135	115
	Input mechanical HP	0.53	0.99	1.41	2.18	3.63	4.51	4.91	5.23	6.45	7.28
	Output torque (lb.in.)	2567	2416	2316	2171	1850	1539	1433	1335	1085	908
	Worm driving efficiency (%)	85	86	87	88	90	90	90	90	89	88
10:1	Input torque (lb.in.)	312	288	273	254	211	176	164	153	125	106
	Input mechanical HP	0.50	0.91	1.30	2.01	3.34	4.19	4.55	4.84	5.96	6.74
	Output torque (lb.in.)	2591	2446	2345	2206	1895	1581	1466	1376	1114	934
	Worm driving efficiency (%)	83	85	86	87	90	90	90	90	89	88
15:1	Input torque (lb.in.)	219	202	191	177	149	124	116	108	89	76
	Input mechanical HP	0.35	0.64	0.91	1.40	2.36	2.96	3.22	3.43	4.23	4.79
	Output torque (lb.in.)	2592	2451	2353	2254	1964	1640	1522	1427	1159	974
	Worm driving efficiency (%)	79	81	82	85	88	88	88	88	87	86
20:1	Input torque (lb.in.)	167	154	146	134	114	96	89	83	68	58
	Input mechanical HP	0.27	0.49	0.70	1.07	1.81	2.28	2.47	2.63	3.25	3.69
	Output torque (lb.in.)	2511	2378	2285	2231	1920	1624	1506	1411	1147	966
	Worm driving efficiency (%)	75	77	78	83	84	85	85	85	84	83
25:1	Input torque (lb.in.)	132	124	118	109	91	77	72	67	55	47
	Input mechanical HP	0.21	0.39	0.56	0.87	1.45	1.84	1.99	2.12	2.62	2.98
	Output torque (lb.in.)	2348	2331	2271	2208	1918	1617	1500	1404	1143	963
	Worm driving efficiency (%)	71	75	77	91	84	84	84	84	83	82
30:1	Input torque (lb.in.)	113	104	99	91	77	65	60	56	46	39
	Input mechanical HP	0.18	0.33	0.47	0.73	1.22	1.54	1.67	1.78	2.20	2.50
	Output torque (lb.in.)	2306	2190	2137	2057	1839	1552	1439	1347	1096	923
	Worm driving efficiency (%)	68	70	72	75	80	80	80	80	79	78
40:1	Input torque (lb.in.)	82	78	74	68	59	49	45	42	35	30
	Input mechanical HP	0.13	0.25	0.35	0.54	0.94	1.16	1.26	1.34	1.66	1.89
	Output torque (lb.in.)	1998	1977	1995	1963	1752	1480	1372	1285	104	880
	Worm driving efficiency (%)	61	63	67	72	74	76	76	76	75	74
50:1	Input torque (lb.in.)	68	63	60	55	47	39	36	34	28	25
	Input mechanical HP	0.11	0.20	0.28	0.44	0.74	0.93	1.01	1.08	1.35	1.56
	Output torque (lb.in.)	1842	1888	1911	1896	1688	1426	1322	1238	1005	847
	Worm driving efficiency (%)	54	60	64	69	72	73	73	73	71	69
60:1	Input torque (lb.in.)	57	53	50	49	39	33	30	28	23	20
	Input mechanical HP	0.09	0.17	0.24	0.37	0.61	0.78	0.84	0.90	1.11	1.27
	Output torque (lb.in.)	1803	1859	1824	1805	1620	1370	1270	1189	965	813
	Worm driving efficiency (%)	53	59	61	65	70	70	70	70	69	68



### Model RG Size 30 (expanded rating table)

Ratio		Worm shaft speed (RPM)									
		100	200	300	500	1000	1500	1750	2000	3000	4000
5:1	Input torque (lb.in.)	869	797	756	684	529	437	407	378	299	248
	Input mechanical HP	1.38	2.53	3.60	5.43	8.40	10.40	11.32	12.08	14.32	15.72
	Output torque (lb.in.)	3869	3586	3439	3112	2434	2005	1866	1738	1360	1114
	Worm driving efficiency (%)	89	90	91	91	92	92	92	92	91	90
6:1	Input torque (lb.in.)	798	732	696	627	491	409	381	351	279	231
	Input mechanical HP	1.27	2.32	3.31	5.02	7.83	9.73	10.57	11.29	13.45	14.75
	Output torque (lb.in.)	4213	3909	3756	3422	2710	2241	2082	1940	1526	1249
	Worm driving efficiency (%)	88	89	90	91	92	91	91	92	91	90
7:1	Input torque (lb.in.)	715	659	627	568	451	372	347	323	258	214
	Input mechanical HP	1.14	2.09	2.99	4.53	7.14	8.86	9.64	10.32	13.34	13.53
	Output torque (lb.in.)	4354	4061	3906	3576	2871	2370	2206	2060	1626	1331
	Worm driving efficiency (%)	87	88	89	90	91	91	91	91	90	89
8:1	Input torque (lb.in.)	660	609	580	528	419	349	325	302	242	201
	Input mechanical HP	1.05	1.93	2.76	4.21	6.67	8.31	9.02	9.67	11.62	12.76
	Output torque (lb.in.)	4543	4241	4082	3759	3050	2531	2349	2196	1742	1428
	Worm driving efficiency (%)	86	87	88	89	91	91	90	91	90	89
9:1	Input torque (lb.in.)	604	552	526	481	387	320	297	279	224	186
	Input mechanical HP	0.96	1.75	2.50	3.82	6.15	7.62	8.25	8.85	10.69	11.77
	Output torque (lb.in.)	4563	4274	4115	3811	3138	2599	2403	2258	1798	1475
	Worm driving efficiency (%)	84	85	87	88	90	90	90	90	89	88
10:1	Input torque (lb.in.)	554	511	485	447	360	298	278	263	210	174
	Input mechanical HP	0.88	1.62	2.31	3.55	5.72	7.11	7.72	8.31	10.06	11.05
	Output torque (lb.in.)	4602	4341	4175	3889	3244	2680	2510	2337	1868	1532
	Worm driving efficiency (%)	83	85	86	87	90	90	90	90	89	88
15:1	Input torque (lb.in.)	390	359	340	312	255	212	197	184	149	125
	Input mechanical HP	0.62	1.14	1.62	2.48	4.05	5.04	5.48	5.96	7.16	7.91
	Output torque (lb.in.)	4621	4356	4188	3977	3372	2790	2590	2433	1950	1607
	Worm driving efficiency (%)	79	81	82	85	88	88	88	88	87	86
20:1	Input torque (lb.in.)	296	275	261	237	196	163	152	142	115	96
	Input mechanical HP	0.47	0.87	1.24	1.91	3.12	3.88	4.21	4.50	5.52	6.12
	Output torque (lb.in.)	4442	4230	4067	3938	3301	2765	2566	2411	1936	1600
	Worm driving efficiency (%)	75	77	78	83	84	85	85	85	84	83
25:1	Input torque (lb.in.)	239	21	210	193	157	132	123	114	93	78
	Input mechanical HP	0.38	0.70	1.00	1.54	2.52	3.13	3.40	3.66	4.46	4.95
	Output torque (lb.in.)	4249	4149	4042	3899	3300	2757	2559	2404	1931	1598
	Worm driving efficiency (%)	71	75	77	81	84	84	84	84	83	82
30:1	Input torque (lb.in.)	202	186	176	161	132	110	103	96	78	65
	Input mechanical HP	0.32	0.59	0.84	1.29	2.11	2.63	2.86	3.05	3.72	4.15
	Output torque (lb.in.)	4113	3896	3803	3631	3162	2642	2453	2303	1849	1531
	Worm driving efficiency (%)	68	70	72	75	80	80	80	80	79	78
40:1	Input torque (lb.in.)	151	140	132	120	102	83	77	72	59	49
	Input mechanical HP	0.24	0.40	0.63	0.96	1.59	1.98	2.15	2.31	2.80	3.13
	Output torque (lb.in.)	3689	3518	3550	3466	3015	2521	2341	2197	1764	1460
	Worm driving efficiency (%)	61	63	67	72	74	76	76	76	75	74
50:1	Input torque (lb.in.)	120	112	106	98	81	67	62	58	48	41
	Input mechanical HP	0.19	0.36	0.51	0.77	1.28	1.59	1.73	1.86	2.26	2.52
	Output torque (lb.in.)	3232	3360	3401	3348	2905	2429	2256	2116	1699	1407
	Worm driving efficiency (%)	54	60	64	69	72	73	73	73	71	69
60:1	Input torque (lb.in.)	101	93	89	82	66	56	52	48	39	33
	Input mechanical HP	0.16	0.30	0.42	0.65	1.05	1.33	1.44	1.54	1.87	2.10
	Output torque (lb.in.)	3205	3309	3246	3186	2789	2332	2167	2032	1630	1350
	Worm driving efficiency (%)	53	59	61	65	70	70	70	70	69	68

# Model RG

## Ratings

### Model RG Size 35 (expanded rating table)

Ratio		Worm shaft speed (RPM)									
		100	200	300	500	1000	1500	1750	2000	3000	4000
5:1	Input torque (lb.in.)	885	885	885	885	885	766	709	662	510	423
	Input mechanical HP	2.55	4.66	6.59	9.79	14.65	18.25	19.68	20.95	24.17	26.86
	Output torque (lb.in.)	7150	6605	6301	5611	4247	3518	3244	3014	2295	1903
	Worm driving efficiency (%)	89	90	91	91	92	92	92	91	90	90
6:1	Input torque (lb.in.)	885	885	885	885	861	717	663	618	477	396
	Input mechanical HP	2.35	4.28	6.09	9.07	13.72	17.08	18.41	19.64	22.72	25.25
	Output torque (lb.in.)	7799	7207	6903	6185	4750	3934	3625	3376	2577	2138
	Worm driving efficiency (%)	88	89	90	90	92	91	91	91	90	90
7:1	Input torque (lb.in.)	885	885	885	885	789	653	605	562	436	365
	Input mechanical HP	2.11	3.86	5.49	8.21	12.50	15.55	16.80	17.92	20.83	23.10
	Output torque (lb.in.)	8058	7485	7185	6477	5027	4162	3844	3577	2744	2271
	Worm driving efficiency (%)	87	88	89	89	91	91	91	91	90	89
8:1	Input torque (lb.in.)	885	885	885	885	734	610	566	529	414	341
	Input mechanical HP	1.95	3.57	5.08	7.63	11.67	14.52	15.72	16.77	19.66	21.70
	Output torque (lb.in.)	8393	7822	7511	6814	5343	4422	4092	3809	2948	2428
	Worm driving efficiency (%)	85	86	87	89	91	91	90	90	89	88
9:1	Input torque (lb.in.)	885	885	885	871	676	557	518	482	380	316
	Input mechanical HP	1.77	3.23	4.60	6.93	10.69	13.27	14.40	15.36	18.15	19.95
	Output torque (lb.in.)	8450	7882	7571	6902	5477	4525	4196	3908	3047	2499
	Worm driving efficiency (%)	84	85	87	88	90	90	90	90	89	88
10:1	Input torque (lb.in.)	885	885	885	809	628	518	484	453	360	294
	Input mechanical HP	1.63	2.99	4.26	6.42	9.96	12.33	13.43	14.33	17.02	18.66
	Output torque (lb.in.)	8510	7995	7682	7041	5648	4651	4331	4032	3166	2587
	Worm driving efficiency (%)	83	85	86	87	90	90	90	89	88	88
15:1	Input torque (lb.in.)	721	660	627	573	448	369	343	322	256	210
	Input mechanical HP	1.14	2.09	2.98	4.52	7.00	8.77	8.54	10.19	12.14	13.31
	Output torque (lb.in.)	8540	8014	7710	7214	5870	4854	4509	4202	3305	2704
	Worm driving efficiency (%)	79	81	82	84	88	88	88	87	86	86
20:1	Input torque (lb.in.)	551	505	480	436	342	283	264	248	198	162
	Input mechanical HP	0.88	1.60	2.29	3.47	5.43	6.74	7.34	7.84	9.36	10.26
	Output torque (lb.in.)	8270	7778	7490	7146	5744	4803	4467	4166	3279	2683
	Worm driving efficiency (%)	75	77	78	82	84	85	85	84	83	83
25:1	Input torque (lb.in.)	448	407	387	354	277	228	213	200	160	130
	Input mechanical HP	0.71	1.29	1.84	2.79	4.38	5.44	5.92	6.33	7.56	8.29
	Output torque (lb.in.)	7950	7627	7444	7075	5741	4785	4452	4153	3270	2675
	Worm driving efficiency (%)	71	75	77	80	83	84	84	84	82	82
30:1	Input torque (lb.in.)	373	341	324	297	232	192	179	168	134	109
	Input mechanical HP	0.59	1.08	1.54	2.34	3.67	4.56	4.97	5.31	6.34	6.95
	Output torque (lb.in.)	7600	7163	7004	6588	5502	4586	4268	3980	3133	2562
	Worm driving efficiency (%)	68	70	72	74	79	80	80	79	78	78
40:1	Input torque (lb.in.)	280	257	244	221	175	144	135	127	101	83
	Input mechanical HP	0.44	0.81	1.16	1.76	2.77	3.43	3.74	4.00	4.78	5.24
	Output torque (lb.in.)	6830	6466	6538	6289	5247	4374	4070	3796	2988	2443
	Worm driving efficiency (%)	61	63	67	71	75	76	76	75	74	74
50:1	Input torque (lb.in.)	225	206	196	179	140	116	108	102	81	66
	Input mechanical HP	0.36	0.65	0.93	1.41	2.22	2.76	3.00	3.21	3.84	4.21
	Output torque (lb.in.)	6070	6176	6263	6075	5055	4214	3922	3657	2877	2352
	Worm driving efficiency (%)	54	60	64	68	72	73	73	72	71	71
60:1	Input torque (lb.in.)	188	172	163	148	117	97	90	85	68	55
	Input mechanical HP	0.30	0.55	0.78	1.18	1.85	2.30	2.51	2.68	3.20	3.51
	Output torque (lb.in.)	5970	6081	5978	5782	4853	4047	3766	3511	2762	2256
	Worm driving efficiency (%)	53	59	61	65	69	70	70	69	68	68

## INSTALLATION, OPERATION & MAINTENANCE INSTRUCTIONS FOR MODEL RG RIGHT GEARHEAD

### Lubrication

Model RG Right Angle Gearheads are factory filled with Mobil SHC634 synthetic lubricant. They require no lubrication service throughout the life of the unit. Model RG Right Angle gearheads are built for universal mounting, ready to mount in any position.

### Installation

Motor on Gearhead:

1. Clean motor shaft and mating surfaces of the motor and gearhead to ensure they are dust free.
2. Slide the motor shaft into the coupling clamp ring until the gearhead and motor flanges are seated together.
3. Use the bolts and nuts provided to clamp the gearhead and motor flanges together.
4. Tighten the clamp ring screw through the access slot in the gearhead flange to the following torque settings:

Tightening Torque of Coupling Bolt		
Unit Sizes	lb. in	Nm
15 & 20	90	10
25, 30	95	10.5
35	220	25

5. Replace the urethane plug in the access slot.

### Hollow Shaft Units:

1. Place key in driven shaft.
2. Slide hollow shaft unit onto the driven shaft.
3. Secure unit to machine base using either a mounting base or torque arm.

### Solid Shaft Units:

1. The gearhead must be securely mounted to a rigid flat foundation or base plate. If necessary, shim under the gearhead to provide a flat mounting surface.
2. Four mounting bolts are required to mount all gearheads. If the gearhead will be subjected to heavy overhung load or thrust loading, heat treated mounting bolts must be used to prevent stretching and loosening of the bolts.
3. The output shaft of the gearhead should be coupled to the driven shaft with a flexible coupling and the gearhead aligned with the shaft, within  $\pm .001$ ". Solid or rigid couplings should be avoided. Failure to properly align shafts and the use of solid couplings can result in excessive coupling and bearing wear, shaft deflection and eventual failure of one or more of the components.

### Ancillary Components:

1. Couplings, sheaves and sprockets should be mounted on the reducer shafts carefully. Do not pound or hammer them onto the shafts as this will damage bearings and oil seals.
2. Sprockets and sheaves should be mounted as close

to the gearhead as possible and "V" belts and chains adjusted to the proper tension to keep bearing loading and shaft deflection to a minimum. Too much tension in belts and improper location of sheaves and sprockets will lead to excessive overhung load, bearing wear and shaft deflection. For specific information on overhung load capacity, shaft stress and bearing life, please contact Cone Drive.

### Start-Up

1. After the gearhead has been properly mounted and aligned, it is ready for start-up.
2. Make sure driven machine is clear of all obstructions and all safety guards and covers are in place. If possible, turn motor shaft by hand to confirm drive system is operating freely and in correct direction of rotation.
3. Jog motor to confirm proper rotation.
4. Operate gearhead with minimum load for approximately 15 minutes (in both directions if applicable) to seal gears, bearings, and oil seals.

### Operation

1. All gearheads require a "run-in" period under load to achieve optimum efficiency. During this initial run-in the gearhead will probably run warmer than normal and draw more current than after the run-in period. Gearheads operating at a very low load or speed will take much longer to run-in and even if operated continuously at low load or speed may never achieve the efficiency that they would if operated at or near their catalog rating.
2. IMPORTANT: Normal gearhead operating temperature measured at the oil sump area of the housing should not exceed 100°F (38°C) above ambient temperature or 200°F (93°C) maximum. If the gearhead operating temperature exceeds these limits, shut down the unit and contact Cone Drive. Excessive oil sump temperature is indicative of overloading, misalignment, or improper or marginal lubrication. Continuous operation of the gearhead with the oil sump temperature above 200°F (93°C) for mineral oils and 250°F (120°C) for synthetic lubricant, will result in failure of the gearhead.

### Maintenance

1. If a gearhead has to be repaired, contact Cone Drive for detailed instruction, blueprints, parts lists, etc. If necessary, field service is available.
2. If a gearhead is to be returned, contact Cone Drive for instructions and a returned material authorization (RMA) number.
3. Please have model number information from the unit name plate recorded.

**Call Parts & Service Toll Free 888-726-2663**

Important

### Product Safety Information

**General** – The following information is important in ensuring safety. It must be brought to the attention of personnel involved in the selection of power transmission equipment, those responsible for the design of the machinery in which it is to be incorporated and those involved in its installation, use and maintenance.

Our equipment will operate safely provided it is selected, installed, used and maintained properly. As with any power transmission equipment **proper precautions must** be taken as indicated in the following paragraphs, to ensure safety.

**Potential Hazards** – these are not necessarily listed in any order of severity as the degree of danger varies in individual circumstances. It is important therefore that the list is studied in its entirety:-

#### 1) Fire/Explosion

- (a) Oil mists and vapor are generated within gear units. It is therefore dangerous to use naked lights in the proximity of gearbox openings, due to the risk of fire or explosion.
- (b) In the event of fire or serious overheating (over 300°C), certain materials (rubber, plastics, etc.) may decompose and produce fumes. Care should be taken to avoid exposure to the fumes, and the remains of burned or overheated plastic/rubber materials should be handled with rubber gloves.

#### 2) Guards- Rotating shafts and couplings must be guarded to eliminate the possibility of physical contact or entanglement of clothing. It should be of rigid construction and firmly secured.

#### 3) Noise – High speed gearboxes and gearbox driven machinery may produce noise levels which are damaging to the hearing with prolonged exposure. Ear defenders should be provided for personnel in these circumstances. Reference should be made to the Department of Employment Code of Practice for reducing exposure of employed persons to noise.

#### 4) Lifting – Where provided (on larger units) only the lifting points or eyebolts must be used for lifting operations (see maintenance manual or general arrangement drawing for lifting point positions). Failure to use the lifting points provided may result in personal injury and/or damage to the product or surrounding equipment. Keep clear of raised equipment.

#### 5) Lubricants and Lubrication

- (a) Prolonged contact with lubricants can be detrimental to the skin. The manufacturer's instruction must be followed when handling lubricants.
- (b) The lubrication status of the equipment must be checked before commissioning. Read and carry out all instructions on the lubricant plate and in the installation and maintenance literature. Heed all warning tags. Failure to do so could result in mechanical damage and in extreme cases risk of injury to personnel.

#### 6) Electrical Equipment – Observe hazard warnings on electrical equipment and isolate power before working on the gearbox or associated equipment, in order to prevent the machinery being started.

#### 7) Installation, Maintenance and Storage

- (a) In the event that equipment is to be held in storage, for a period exceeding 6 months, prior to installation or commissioning, we must be consulted regarding special preservation requirements. Unless otherwise agreed, equipment must be stored in a building protected from extremes of temperature and humidity to prevent deterioration. The rotating components (gears and shafts) must be turned a few revolutions once a month (to prevent bearings brinelling).
- (b) External gearbox components may be supplied with preservative materials applied, in the form of a "waxed" tape overwrap or wax film preservative. Gloves should be worn when removing these materials. The former can be removed manually, the latter using white spirit as a solvent. Preservatives applied to the internal parts of the gear units do not require removal prior to operation.
- (c) Installation must be performed in accordance with the manufacturer's instructions and be undertaken by suitably qualified personnel.
- (d) Before working on a gearbox or associated equipment, ensure that the load has been removed from the system to eliminate the possibility of any movement of the machinery and isolate power supply. Where necessary, provide mechanical means to ensure the machinery cannot move or rotate. Ensure removal of such devices after work is complete.
- (e) Ensure the proper maintenance of gearboxes in operation. Use only the correct tools and our approved spare parts for repair and maintenance. Consult the Maintenance Manual before dismantling or performing maintenance work.

#### 8) Hot Surfaces and Lubricants

- (a) During operation, gear units may become sufficiently hot to cause skin burns. Care must be taken to avoid accidental contact.
- (b) After extended running the lubricant in gear units and lubrication systems may reach temperatures sufficient to cause burns. Allow equipment to cool before servicing or performing adjustments.

#### 9) Selection and Design

- (a) Where gear units provide a backstop facility, ensure that back-up systems are provided if failure of the backstop device would endanger personnel or result in damage.
- (b) The driving and driven equipment must be correctly selected to ensure that the complete machinery installation will perform satisfactorily, avoiding system critical speeds, system torsional vibration, etc.
- (c) The equipment must not be operated in an environment or at speeds, powers, torques or with external loads beyond those for which it was designed.
- (d) As improvements in design are being made continually the contents of this catalogue are not to be regarded as binding in detail, and drawings and capacities are subject to alterations without notice.

The above guidance is based on the current state of knowledge and our best assessment of the potential hazards in the operation of the gear units.

Any further information or clarification required may be obtained by contacting our Application Engineers.

# Notes

# Notes



 GLOBAL LOCATIONS



Cone Drive Operations, Inc.  
240 East 12th Street  
Traverse City, Michigan 49684  
USA

Cone Drive Europe  
1 Redwood Crescent, Peel Park  
East Kilbride G74 5PA  
UK

H-Fang  
A Cone Drive Brand  
No. 20 Yungu Road  
Changshou  
Zhouzhuang Town, Jiangyin  
Jiangsu PR China 214424

T +1 888 994 2663  
E [orders@conedrive.com](mailto:orders@conedrive.com)  
W [www.conedrive.com](http://www.conedrive.com)